

Operations Manual EZDP-2123 Rev C

Compact Brush Condition Monitoring



Table of Contents

1. About Cutsforth	4
1.1. Cutsforth Products	4
1.2. Cutsforth Field Services	4
1.3. Cutsforth Automation and Control Services	4
2. Legal Information	5
2.1. Limited Warranty	5
2.2. Copyright	6
2.3. Patents	6
2.4. Federal Communications Commission Requirements	6
2.4.1. Compact Brush Condition Monitoring System	6
2.4.2. Brush Health Sensor	6
2.5. ISED Canada Regulatory Compliance Statement	7
3. Safety Information	8
3.1. Safety Information [English]	8
3.1.1. Safety Conventions	8
3.1.2. General Safety Instructions	8
3.2. Consignes de Sécurité [Français]	9
3.2.1. Conventions de Sécurité	9
3.2.2. Consignes de Sécurité Générales	10
4. EASYchange® Compact Brush Condition Monitoring	11
5. Compact Brush Condition Monitoring (cBCM) Technical Specifications	13
5.1. Compact Brush Condition Monitor Technical Specifications	13
5.1.1. Product Certifications	13
5.1.2. Environmental Specifications	14
5.1.3. AC Power Supply Requirements	14
5.1.4. AC Power Specifications	14
5.2. Brush Health Sensor Technical Specifications	14
5.2.1. Product Certifications	14
5.2.2. Environmental and Power Specifications	15
5.3. Waste Electrical and Electronic Equipment (WEEE) Directive	15
5.4. Data from Compact BCM System	16
5.5. Integration and Infrastructure	16
6. Compact Brush Condition Monitoring System	17
7. Compact Brush Condition Monitoring System Installation	18
7.1. Mounting the Compact Brush Condition Monitoring System Enclosure	19
7.1.1. Compact Brush Condition Monitoring System Mounting Requirements	19
7.2. Running Power to the Compact Brush Conditioning Monitoring System	20
7.3. Route the Antenna Cabling	21
7.4. Install Brush Holder Label Clips	22
8. Brush Health Sensors	23
8.1. Pair a New Sensor	23
8.2. Frequency of Sensor Updates	24
8.3. Unpair a Sensor	24
8.3.1. Replacing a Brush	24
8.4. Brush Health Sensor Battery Life	25
8.5. Button-On Self Test	26
9. Using the cBCM System User Interface	27

9.1. Power On the cBCM System	27
9.2. cBCM System Screen Layout	27
9.3. Navigating the cBCM System Screen	29
9.4. Power Off the cBCM System	30
10. Brush Status Indication	31
10.1. Color Definitions	32
11. Configure the Compact Brush Condition Monitoring System Settings	33
12. Advanced Configuration Settings	35
12.1. Access the Advanced Configuration Window	36
12.2. Export Data and Event Logs	37
12.3. Update the Compact Brush Condition Monitoring Application	38
12.4. Update the Brush Health Sensor Firmware	39
12.5. Set the Compact Brush Condition Monitoring System Time	40
13. Generator Settings	43
13.1. Measurement Interval	44
14. Antenna Placement Mode	45
15. Modbus Interface	47
15.1. Entering a Static IP Address	51
15.2. Locating the MAC Addresses	55
15.3. Modbus RTU Configuration	57
16. Frequently Asked Questions (FAQ)	59
17. Glossary	61

1. About Cutsforth

Cutsforth specializes in developing innovative new technologies and services to support the power generation industry. Cutsforth's patented EASYchange® brush holder design, online truing service, InsightCM™ condition monitoring software, and patented shaft grounding and monitoring systems have been installed across the globe in generators of all sizes and in nearly every industry application, including nuclear, natural gas, coal, wind, and hydroelectric.

Cutsforth's knowledge and commitment to excellence drives our innovative solutions for the changing needs of the power industry. Whether it is a quick response to a critical situation or a new way of solving an old problem, our commitment to quality ensures that our customers receive best-in-class products and services—Cutsforth is the Power of Innovation.

Cutsforth started back in 1991 as a small company focused primarily on making replacement brush holders for generators and exciters. Today, after 30+ years in business, Cutsforth's experience and innovative designs have brought its best-in-class excitation brush holder and shaft grounding replacements and collector ring services to some of the world's largest power companies.

1.1. Cutsforth Products

- [EASYchange® Removable Brush Holders](#)
- [EASYchange® Brush Condition Monitoring](#)
- [Cutsforth Shaft Grounding Systems](#)
- [Rotor Flux Monitoring](#)
- [Electro-Magnetic Interference Monitoring](#)
- [InsightCM™ Condition Monitoring Software](#)

1.2. Cutsforth Field Services

Cutsforth provides comprehensive product installations for all product offerings as well as on-site training after the installation. We work efficiently during your outage to ensure a smooth upgrade to our innovative solutions such as Product Installations, Online Collector Ring and Commutator Truing, Spiral Groove Restoration, and Consulting and Emergency Services.

1.3. Cutsforth Automation and Control Services

Cutsforth provides comprehensive Automation and Control services which include data historian integration, InsightCM™ integration, DCS logic, engineered drawings and much more. This further complements our turnkey monitoring system installations.

2. Legal Information

2.1. Limited Warranty

This document is provided 'as is' and is subject to being changed, without notice, in future editions. Cutsforth reviews this document carefully for technical accuracy; however, CUTSFORTH MAKES NO EXPRESS OR IMPLIED WARRANTY AS TO THE ACCURACY OF THE INFORMATION WITHIN THIS MANUAL AS IT RELATES TO SPECIFIC INSTALLATION. THE CUSTOMER IS RESPONSIBLE FOR VERIFYING INSTALLATION AND OPERATING CONDITIONS AT EACH INSTALLATION LOCATION AND FOR EACH GENERATOR TYPE. Cutsforth warrants that its hardware products will be free of defects in materials and workmanship that cause the product to fail to substantially conform to the applicable Cutsforth published specifications for one (1) year from the date of invoice.

For a period of ninety (90) days from the date of invoice, Cutsforth warrants that (i) its software products will perform substantially in accordance with the applicable documentation provided with the software, and (ii) the software media will be free from defects in materials and workmanship. If Cutsforth receives notice of a defect or non-conformance during the applicable warranty period, Cutsforth will, in its discretion: (i) repair or replace the affected product, or (ii) refund the fees paid for the affected product. Repaired or replaced hardware will be warranted for the remainder of the original warranty period or ninety (90) days, whichever is longer. If Cutsforth elects to repair or replace the product, Cutsforth may use new or refurbished parts or products that are equivalent to new in performance and reliability and are at least functionally equivalent to the original part or product. You must obtain an RMA number from Cutsforth before returning any product to Cutsforth. Cutsforth reserves the right to charge a fee for examining and testing hardware not covered by the Limited Warranty.

This Limited Warranty does not apply if the defect of the product resulted from improper or inadequate maintenance, installation, repair, or calibration performed by a party other than Cutsforth; unauthorized modification; improper environment; use of an improper hardware or software key; improper use or operation outside of the specification for the product; improper voltages; accident, abuse, or neglect; or a hazard such as lightning, flood, or other act of nature.

THE REMEDIES SET FORTH ABOVE ARE EXCLUSIVE AND THE CUSTOMER'S SOLE REMEDIES, AND SHALL APPLY EVEN IF SUCH REMEDIES FAIL OF THEIR ESSENTIAL PURPOSE.

WARNING REGARDING USE OF CUTSFORTH SHAFT MONITORING EQUIPMENT: CUSTOMER IS ULTIMATELY RESPONSIBLE FOR VERIFYING AND VALIDATING THE SUITABILITY AND RELIABILITY OF THE PRODUCTS WHENEVER THE PRODUCTS ARE INCORPORATED IN THEIR SYSTEM OR APPLICATION, INCLUDING THE APPROPRIATE DESIGN, PROCESS, AND SAFETY LEVEL OF SUCH SYSTEM OR APPLICATION. PRODUCTS ARE NOT DESIGNED, MANUFACTURED, OR TESTED FOR USE IN LIFE OR SAFETY CRITICAL SYSTEMS, OR ANY OTHER APPLICATION IN WHICH THE FAILURE OF THE PRODUCT OR SERVICE COULD LEAD TO DEATH, PERSONAL INJURY, SEVERE PROPERTY DAMAGE OR ENVIRONMENTAL HARM (COLLECTIVELY, "HIGH-RISK USES"). FURTHER, PRUDENT STEPS MUST BE TAKEN TO PROTECT AGAINST FAILURES, INCLUDING PROVIDING BACK-UP AND SHUT-DOWN MECHANISMS. CUTSFORTH EXPRESSLY DISCLAIMS ANY EXPRESS OR IMPLIED WARRANTY OF FITNESS OF THE PRODUCTS OR SERVICES FOR HIGH-RISK USES.

CUTSFORTH DOES NOT WARRANT, GUARANTEE, OR MAKE ANY REPRESENTATIONS REGARDING THE USE OF OR THE RESULTS OF THE USE OF THE PRODUCTS IN TERMS OF CORRECTNESS, ACCURACY, RELIABILITY, OR OTHERWISE. CUTSFORTH DOES NOT WARRANT THAT THE OPERATION OF THE PRODUCTS WILL BE UNINTERRUPTED OR ERROR FREE. INCIDENTAL AND CONSEQUENTIAL DAMAGES, INCLUDING LOSS OF USE, ARE SPECIFICALLY EXCLUDED FROM THIS WARRANTY; THE MAXIMUM VALUE OF A WARRANTY CLAIM CANNOT EXCEED THE ORIGINAL VALUE OF THE ASSEMBLY OR COMPONENT.

2.2. Copyright

Under copyright law, this publication may not be reproduced or transmitted in any form, electronic or mechanical, including photocopying, recording, storing in an information retrieval system, or translating, in whole or in part, without the prior written consent of Cutsforth. Cutsforth respects the intellectual property of others, and we ask our users to do the same. Cutsforth software is protected by copyright and other intellectual property laws. Cutsforth software is only licensed to be run on the intended hardware for which it was purchased. Reproduction of software or written materials is prohibited unless Customer has obtained a license for that express purpose.

2.3. Patents

Please send patent information requests to patents@cutsforth.com.

2.4. Federal Communications Commission Requirements

2.4.1. Compact Brush Condition Monitoring System

Utilizes Intel RF module 8265NG

FCC ID: PD98265NG

IC ID: 1000M-8265NG

2.4.2. Brush Health Sensor

Part #: EBHS001

FCC ID: 2ARPJ-EBHS001

IC ID: 24545-EBHS001

This device complies with part 15 of the FCC Rules. Operation is subject to the following two conditions:

(1) This device may not cause harmful interference, and

(2) this device must accept any interference received, including interference that may cause undesired operation.



Caution: User changes or modifications not expressly approved by the party responsible for compliance could void the user's authority to operate the equipment.



Note: This equipment has been tested and found to comply with the limits for a Class A digital device, pursuant to part 15 of the FCC Rules. These limits are designed to provide reasonable protection against harmful interference when the equipment is operated in a commercial environment. This equipment generates, uses, and can radiate radio frequency energy and, if not installed and used in accordance with the instruction manual, may cause harmful interference to radio communications. Operation of this equipment in a residential area is likely to cause harmful interference in which case the user will be required to correct the interference at his own expense.

2.5. ISED Canada Regulatory Compliance Statement

This device contains licence-exempt transmitter(s)/receiver(s) that comply with Innovation, Science and Economic Development Canada licence-exempt RSS(s). Operation is subject to the following two conditions:

1. This device may not cause interference.
2. This device must accept any interference, including interference that may cause undesired operation of the device.

L'émetteur/récepteur exempt de licence contenu dans le présent appareil est conforme aux CNR d'Innovation, Sciences et Développement économique Canada applicables aux appareils radio exempts de licence. L'exploitation est autorisée aux deux conditions suivantes :

1. L'appareil ne doit pas produire de brouillage;
2. L'appareil doit accepter tout brouillage radioélectrique subi, même si le brouillage est susceptible d'en compromettre le fonctionnement.

3. Safety Information

3.1. Safety Information [English]

Following is important safety information. For safe installation and operation of this equipment, be sure to read and understand all cautions and warnings.

3.1.1. Safety Conventions



NOTE:

Additional information.



ELECTRICAL DANGER

Indicates an action or specific equipment area that can result in personal injury or death from an electrical hazard if proper precautions are not taken.



CAUTION

Indicates a hazardous situation that, if not avoided, could result in minor or moderate injury or equipment damage.



WARNING

Indicates a hazardous situation that, if not avoided, could result in death or serious injury.



ROTATING PART CAUTION

Indicates possible injury from rotating parts.



DANGER

Indicates a hazardous situation that, if not avoided, will result in death or serious injury.

3.1.2. General Safety Instructions



ELECTRICAL DANGER

Only qualified personnel who recognize shock hazards and are familiar with the safety precautions required to avoid injury should work with Cutsforth products. Among the many considerations are the following:

- Avoid contact with energized circuits.
- Avoid contact with rotating parts.
- Never install any component that appears not to be functioning in a normal manner.
- Always ensure proper installation of the holder assembly and shaft grounding rope.



ELECTRICAL DANGER

Before working on the generator, de-energize, lock out, and tag out all power sources to the generator, shaft, and accessory devices. Electric shock and death may result due to failure to heed this warning.



ROTATING PART CAUTION

High-voltage and rotating parts can cause serious or fatal injury. Installation, operation, and maintenance of this product must be performed only by qualified personnel, in accordance with all applicable safety regulations and guidelines.



WARNING

Never mix different carbon brush grades or brushes from different manufacturers on the same unit.

3.2. Consignes de Sécurité [Français]

Les informations qui suivent sont essentielles afin d'assurer la sécurité de l'utilisateur lors de l'installation et de l'opération de l'équipement. Assurez-vous de bien lire et de comprendre tous les avertissements et mises en garde qui suivent.

3.2.1. Conventions de Sécurité



NOTE:

Informations supplémentaires.



RISQUES DE CHOC ÉLECTRIQUE

Indique que l'action ou la partie de l'équipement concernée peut mener à des blessures par électrisation ou à la mort par électrocution si les précautions adéquates ne sont pas prises.



MISE EN GARDE

Indique la présence d'une situation dangereuse qui, si elle n'est pas évitée, pourrait mener à des blessures mineures à modérées ou à des dommages matériels.



AVERTISSEMENT

Indique la présence d'une situation dangereuse qui, si elle n'est pas évitée, pourrait mener à des blessures sévères ou à la mort.



MISE EN GARDE : PIÈCE ROTATIVE

Indique la présence de pièces d'équipement rotatives pouvant causer des blessures.



DANGER

Indique la présence d'une situation dangereuse qui, si elle n'est pas évitée, pourrait mener à des blessures sévères ou à la mort.

3.2.2. Consignes de Sécurité Générales



RISQUES DE CHOC ÉLECTRIQUE

L'utilisation des produits Cutsforth n'est recommandée qu'aux professionnels qualifiés qui savent comment reconnaître la présence de risques de choc électrique ainsi que les consignes de sécurité à suivre pour éviter les blessures liées à ces risques. Lesdites consignes de sécurité incluent, sans s'y limiter :

- Éviter tout contact avec des circuits alimentés;
- Éviter tout contact avec des pièces d'équipement rotatives;
- Ne jamais installer de composante ne paraissant pas fonctionner normalement;
- Toujours s'assurer que la structure de soutien et le câble de terre de l'arbre de la génératrice sont correctement installés.



RISQUES DE CHOC ÉLECTRIQUE

Avant de travailler sur la génératrice, désalimentez, cadenassez et étiquetez toutes les sources d'énergies liées à la génératrice, à l'arbre et aux appareils accessoires. L'opérateur s'expose à des risques de chocs électriques pouvant causer la mort s'il ne tient pas compte de cet avertissement.



MISE EN GARDE : PIÈCE ROTATIVE

Les pièces d'équipement rotatives et sous haute tension peuvent causer des blessures sévères ou fatales. L'installation, l'opération et la manutention de ce produit ne doivent être faites que par des professionnels qualifiés et en respectant toutes les règles et consignes de sécurité applicables.



AVERTISSEMENT

Ne jamais utiliser de frotteurs de différentes qualités ou venant de différents fabricants sur le même appareil.

4. EASYchange® Compact Brush Condition Monitoring

For over 30 years, Cutsforth has installed over 35,000 of the best-in-class brush holders on turbine generators worldwide. Now, with our exclusive EASYchange® Compact Brush Condition Monitoring, Cutsforth offers an even better way to operate your generator's brush-type excitation. Brush performance metrics can now be delivered to the control room system and maintenance can be performed based on brush condition, rather than a calendar.

Automated measurements and brush health analytics allow plant operators to improve the efficiency of technicians' daily and weekly tasks by dispatching them to the collector when maintenance is actually needed.

The Compact Brush Condition Monitoring System is composed of:

- a Cutsforth-developed industrial data logger product known as the Brush Health Sensor (BHS) **(A)** shown installed on the EASYchange® brush holder, and
- a Sensor Controller touch-screen interface **(B)** that compiles the data collected from several BHS units installed with the EASYchange® brush holders.



Cutsforth's patented hardware and technology processes and transmits the following data points over a 2.4 GHz wireless link to local displays as well as via Modbus protocol into a plant's DCS, Historian, or InsightCM™.

5. Compact Brush Condition Monitoring (cBCM) Technical Specifications

5.1. Compact Brush Condition Monitor Technical Specifications

5.1.1. Product Certifications

Table 1. EU Directive Information – CE Compliance

Electro Magnetic Compatibility (EMC) Directive 2014/30/EU	EN 61326-1:2013 EN IEC 61000-3-2: 2019+A1: 2021 EN 61000-3-3:2013+A2:2021
Safety Low Voltage Directive (LVD) 2014/35/EU	EN 61010-1:2010+A1:2019
RoHS Directive 2011/65/EU	Large Scale Fixed Installation Exclusion

Table 2. North America

Electromagnetic Compatibility (EMC)	Conforms to FCC 47 CFR Part 15 Subpart B (05/2024) Certified to CSA Std ICES-003 Issue 7 Oct 2020
Safety	CSA C22.2 #61010-1-12:2012 Ed. 3 + U1;U2;A1 UL 61010-1:2012 Ed.3 + R:19Jul2019

Table 3. UK Conformity Assessment – UKCA

Electro Magnetic Compatibility (EMC) 2016	EN 61326-1:2013
Electrical Equipment Safety Regulation 2016	EN 61010-1:2010
Regulation Restriction of Hazardous Substances (RoHS)	Large Scale Fixed Installation Exclusion

Markings for EBMA-201:



5.1.2. Environmental Specifications

Operating Temperature	0 °C to 70 °C (-4 °F to 158 °F)
Operating Humidity	10% RH to 90% RH, non-condensing
Enclosure Ratings	NEMA Type 3R, 4, 4X, 12, 13 IP66

5.1.3. AC Power Supply Requirements

Plant-supplied power source	120 V, 60 Hz or 240 V, 50 Hz AC
Circuit breaker	Internal 120V, 5 A
Current draw under normal usage	Approximately 0.6 A

5.1.4. AC Power Specifications

Input Voltage Range	85 – 264 VAC
Input Frequency Range	47 – 63 Hz
Input Power Rating	150 W
Over Voltage Category	III; According to EN62368, EN61558, EN50178, EN60664-1, EN62477-1
Input Wire Connection Type	Screw Terminal
Input Wire Size	30 - 10 AWG

5.2. Brush Health Sensor Technical Specifications

5.2.1. Product Certifications

Table 4. EU Directive Information – CE Compliance

Electro Magnetic Compatibility (EMC) Directive 2014/30/EU	EN 50663: 2017
Safety Low Voltage Directive (LVD) 2014/35/EU	EN 62479: 2010
RoHS Directive 2011/65/EU	EN 61010-1:2010+A1:2019
Radio Equipment Directive (RED) 2014/53/EU	Large Scale Fixed Installation Exclusion
	ETSI EN 300 328 V2.2.2 (2019-07)
	ETSI EN 301 489-1 V2.2.3 (2019-11)
	ETSI EN 301 489-17 V3.2.4 (2020-09)

Table 5. North America

Electromagnetic Compatibility (EMC)	Conforms to FCC 47 CFR Part 15 Subpart B (05/2024) Certified to CSA Std ICES-003 Issue 7 Oct 2020
Safety	Out of scope, 9VDC device

Radio	CFR47 FCC Part 15.247 Subpart C: 04/201 CFR47 FCC Part 15 Subpart B: 04/2019 RSS-247 Issue 2 02/2017 ICES-003 Issue 6: 01/2016 Updated: 04/2019 RSS-Gen Issue 5 04/2018 RSS-102 Issue 5 03/2015 KDB 558074 D01 15.247 Measurement Guidance v05r02
-------	---

Table 6. UK Conformity Assessment – UKCA

Electro Magnetic Compatibility (EMC) Directive 2014/30/EU	EN 50663: 2017
Safety Low Voltage Directive (LVD) 2014/35/EU	EN 62479: 2010
RoHS Directive 2011/65/EU	EN 61010-1:2010+A1:2019
Radio Equipment Directive (RED) 2014/53/EU	Large Scale Fixed Installation Exclusion ETSI EN 300 328 V2.2.2 (2019-07) ETSI EN 301 489-1 V2.2.3 (2019-11) ETSI EN 301 489-17 V3.2.4 (2020-09)

Markings for EBHS-001:



5.2.2. Environmental and Power Specifications

Operating Temperature	0 °C to 105 °C (32 °F to 221 °F)
Enclosure Ratings	IP6X dustproof
Power	Battery
Battery Type	Lithium metal (non-replaceable)
User Interface	Push-button activation
Feedback mode	LED indication

5.3. Waste Electrical and Electronic Equipment (WEEE) Directive

WEEE Directive Statement

In accordance with Article 14 of Directive 2012/19/EU on Waste Electrical and Electronic Equipment (WEEE), the following marking requirements apply:

- The directive applies to electrical and electronic equipment falling under Annex I, Category 9 of Directive 2012/19/EU.
- Products must include markings that clearly identify the producer and indicate that the equipment was placed on the market after 13 August 2005.
- The crossed-out wheeled bin symbol signifies that the equipment must not be disposed of with unsorted municipal waste. End users are required to follow applicable local recycling and disposal procedures for electrical and electronic equipment.
- The marking affixed to the product confirms that it falls within the scope of this directive.

Marking for the WEEE Directive; Appears on all products sold into the EU:



5.4. Data from Compact BCM System

Most Recent Recorded Values (Local)	Configurable Brush Health Alerts (Local)	Historical Data Trending (Output to Historian)
<ul style="list-style-type: none"> ▪ Usable Brush Length (%) ▪ Brush Vibration (Mils Displacement, Pk-to-Pk) ▪ Temperature 	<ul style="list-style-type: none"> ▪ Brush Length Warnings ▪ High Vibration ▪ Temperature 	<ul style="list-style-type: none"> ▪ Usable Brush Length ▪ Vibration ▪ Ambient Temperature at Brush Health Sensor (BHS) ▪ BHS Battery Life ▪ System Status ▪ System Date/Time ▪ Temperature <p>See Modbus Interface (page 47) for a complete list.</p>

5.5. Integration and Infrastructure

The Compact Brush Condition Monitoring (cBCM) System is equipped with an integrated touchscreen user interface that provides local configuration, visualization, and system status monitoring. An optional secondary display may be installed to support additional viewing locations. The cBCM System communicates wirelessly with the Brush Health Sensors using a 2.4 GHz RF Bluetooth® Low Energy (BLE) connection, enabling reliable data transmission in industrial environments. For integration with plant DCS or historian systems, the cBCM System supports multiple data output interfaces, including Modbus TCP/IP over Ethernet, Modbus RS-232, and Modbus RS-485.

If desired, the Modbus data from the cBCM System can be inputted into Cutsforth's InsightCM™ software. For more information on InsightCM™, including specific server requirements, visit the InsightCM™ README on the Cutsforth Support webpage at <https://support.cutsforth.com>.

6. Compact Brush Condition Monitoring System

The Compact Brush Condition Monitoring System receives data from the Brush Health Sensors (BHS) at regular intervals. It presents information based on the received data to users locally using up to two industrial displays, and to remote users over Modbus TCP, Modbus RTU, or over Ethernet into InsightCM™ software.

At the generator, the cBCM System user interface visually alerts users of short brushes and high vibrations based on plant-defined thresholds. This same critical data and more can also be relayed to the control room, reducing unnecessary physical inspections.

Brush health historical analytics are logged by the system and available on the Brush Detail screen for each brush holder location. Ultimately, the combination of recent and historical brush health analytics will improve operator efficiencies and optimize a plant's staff utilization.



7. Compact Brush Condition Monitoring System Installation

This section covers the installation process of the Brush Condition Monitoring System and the routing of the antenna signal wire. Before beginning the installation, thoroughly review the Brush Condition Monitoring System Installation Planning Guide (EZDP-2061). The major installation steps consist of:

1. [Mounting the Compact Brush Condition Monitoring System Enclosure \(page 19\)](#)
2. [Running Power to the Compact Brush Conditioning Monitoring System \(page 20\)](#)
3. [Route the Antenna Cabling \(page 21\)](#)
4. [Install Brush Holder Label Clips \(page 22\)](#)

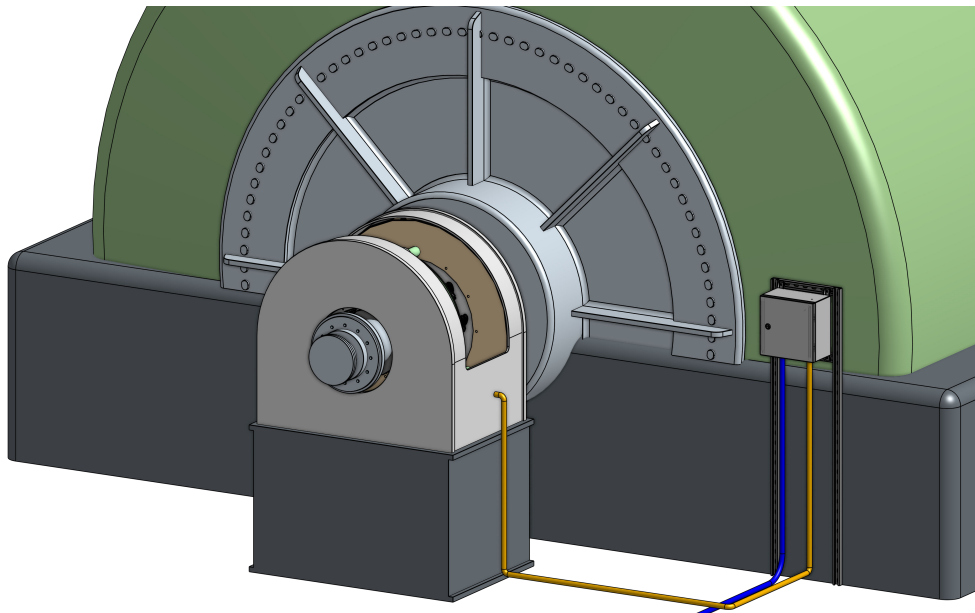

7.1. Mounting the Compact Brush Condition Monitoring System Enclosure

This section covers the placement and mounting requirements for the Compact Brush Condition Monitoring System enclosure.

7.1.1. Compact Brush Condition Monitoring System Mounting Requirements

The Compact Brush Condition Monitoring System **(A)** requires a minimum of two Unistrut rails **(B)** for mounting. Mount the enclosure as close to the exciter brushes as possible, while maintaining operator safety, to optimize the user experience.

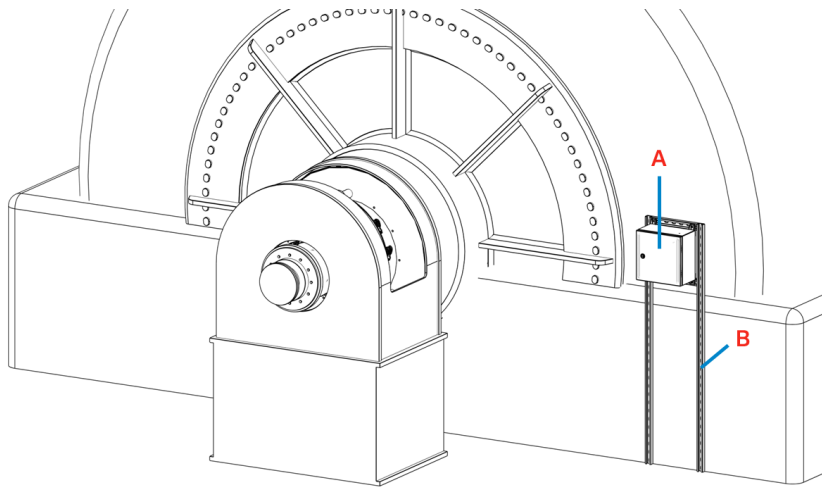

7.2. Running Power to the Compact Brush Conditioning Monitoring System

The Compact Brush Condition Monitoring System has an internal enclosed AC/DC converter which requires power input of 85–264 VAC at 47–63 Hz. The power output of the internal power supply is 24V, 6.25A DC (150W max). The power input cabling should be run to the Compact Brush Condition Monitoring System in liquid-tight conduit **(A)**.

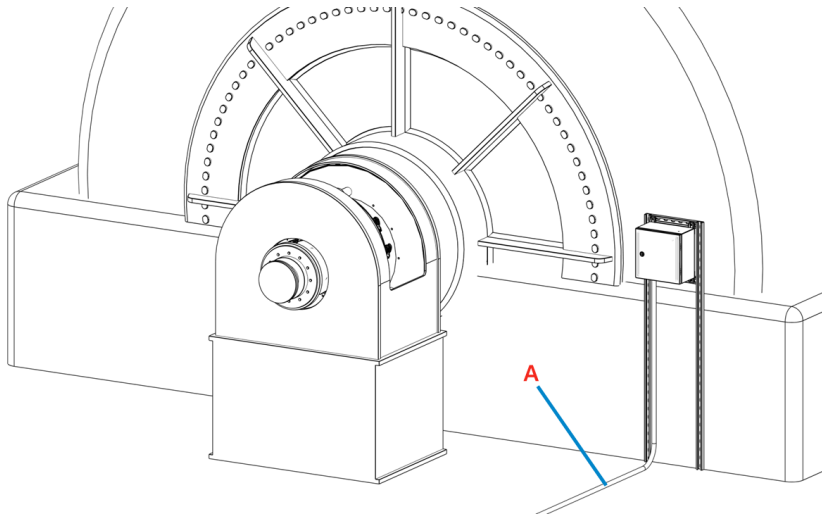

7.3. Route the Antenna Cabling

The Compact Brush Condition Monitoring System requires the use of an antenna to enable ideal communication to and from the Brush Health Sensors. The ideal antenna mounting location may vary between installations. If you are unsure about the placement of the antenna, refer to the [Antenna Placement Mode \(page 45\)](#) section of this manual.

In most cases, the ideal antenna location will be inside the exciter housing. If this is the case:

1. Drill a hole through the lower portion of the exciter housing **(A)**.
2. Mount the antenna to the inside of the exciter housing with its connector extending through the newly drilled hole.
3. On the outside of the exciter housing, route liquid-tight conduit from the antenna to the Compact Brush Condition Monitoring System **(B)** to run the antenna cable **(C)**.

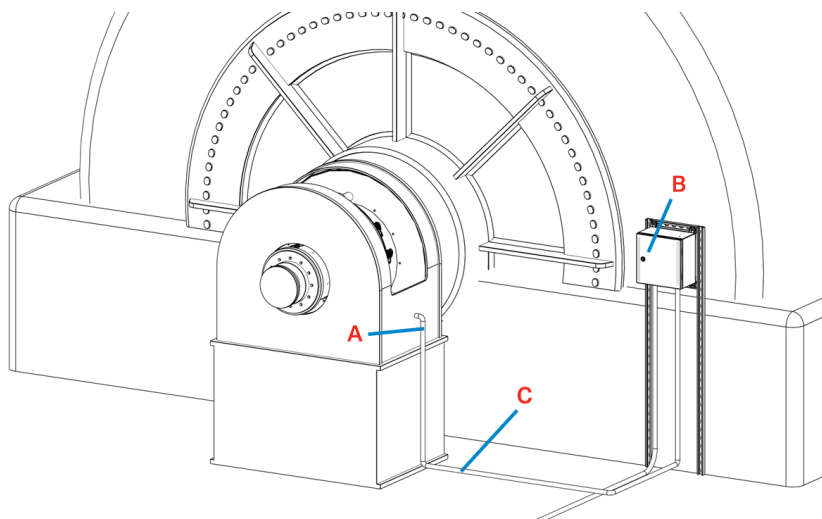

7.4. Install Brush Holder Label Clips

Installing brush holder label clips can assist in easily identifying brush positions as they relate to the Compact Brush Condition Monitoring System display. The label clips often use an alphanumeric nomenclature to identify the row and path of each brush. For example, brush '2B' would refer to the brush located in row '2' and path 'B'.

To install the label clips:

1. Orient the label clips **(A)** as shown.

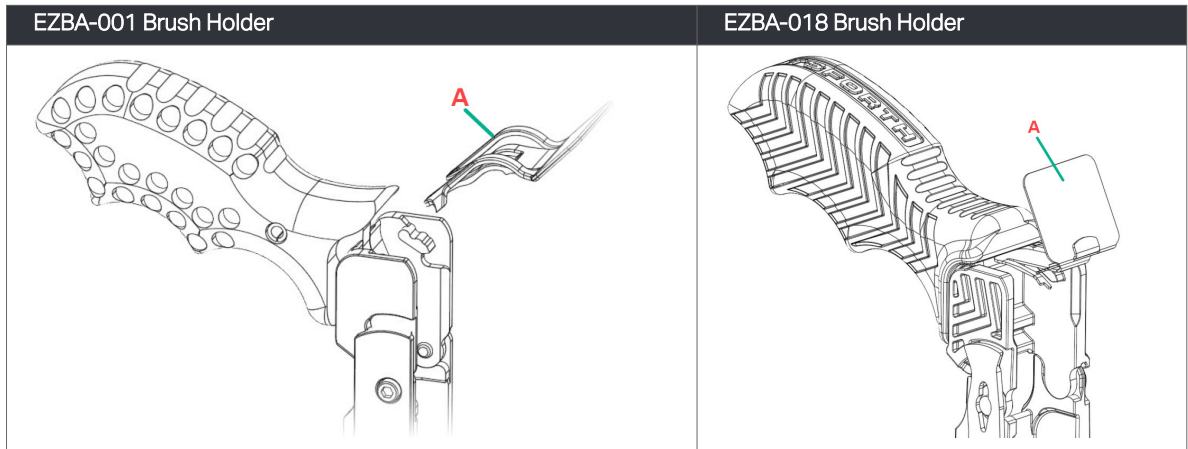

2. Guide the label clip **(A)** under the brush holder handle until you feel the label clip lock into place. The final resting position is shown here:

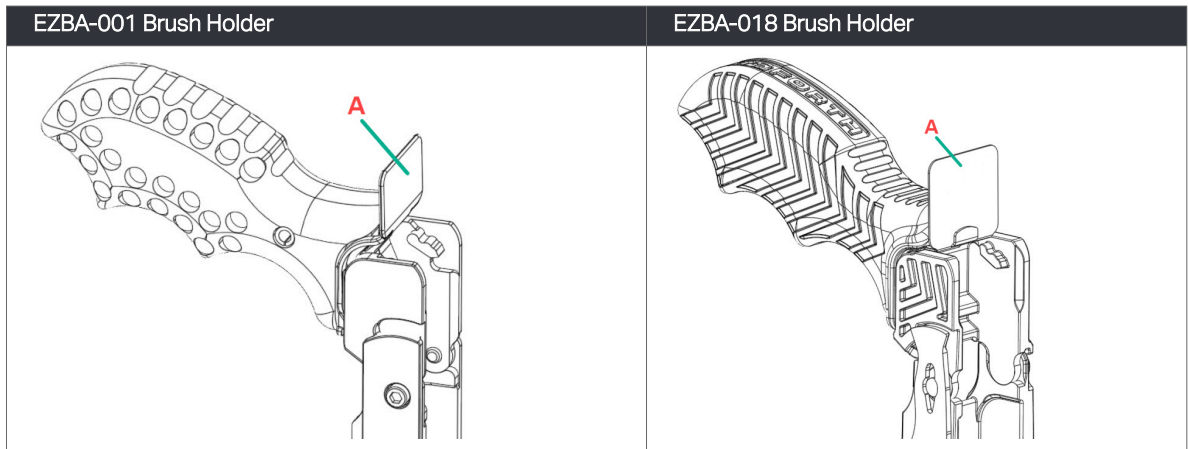

8. Brush Health Sensors

The Brush Health Sensor (BHS) is a data logging device that processes sensor data and reports it back to the Sensor Controller at a regular interval over a 2.4 GHz wireless link. Up to 216 Brush Health Sensors may be connected to a single monitoring system. The 2.4 GHz antenna is a PCB trace style antenna.



8.1. Pair a New Sensor

To pair a new sensor:

1. From the home screen, select the brush holder location where you want to place the new sensor.
2. When that brush holder location's menu appears, push **Press to Pair New Sensor**.

Brush Details

Location: 3D

Disable

Alternate Color

Press to Pair
New Sensor

90%

Brush Life
Remaining

0.6

Mils Pk-Pk

19

Celsius

Clear Brush
Length Warnings

Sensor Pairing Date 2022-08-17 10:06:41 PDT

Sensor Pairing Age (days)	0
Measurement Count	3
Brush Install Date	UNKNOWN
Brush Age (days)	UNKNOWN

Recent Displacements	1.0	1.0	1.1	-	-	-
Recent Temperatures	19	18	18	-	-	-

3. Press the button on the sensor you wish to pair.
4. Wait until a "pairing successful" message is returned.
5. Once pairing has successfully completed, install the brush and sensor in the proper position on the collector ring.



SENSOR NOT PAIRING? FOLLOW THESE STEPS:

- If a confirmation message does not appear, that sensor could be paired to another location.
- You can check if the sensor is paired somewhere else by following the instructions under first FAQ question.
- If you want to relocate the sensor to a different holder or location, or have confirmed the sensor is not paired with another location, simply unpair the sensor and repeat the pairing process.
- Still unable to pair the sensor? Submit a support request at Cutsforth.com/Support.

8.2. Frequency of Sensor Updates

Sensors are factory programmed to update data and communicate with the cBCM System once every hour. However, the operator can manually wake up the sensor at any time by pressing the button **(A)** on the sensor. This forces the cBCM System to collect data from that sensor at that time. The frequency of the automatic sensor data updates can be adjusted from the Advanced Configuration screen.

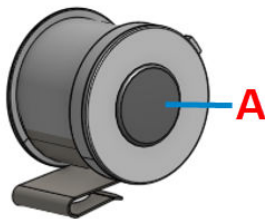

8.3. Unpair a Sensor

To unpair a sensor, press and hold the button on the sensor for three seconds until the two LEDs on the sensor flash three times.

This indicates that the sensor has been unpaired. The data for that sensor/location will remain visible on the cBCM System home page until the next regular data collection interval passes. At that point, the cBCM System home screen will update accordingly.

8.3.1. Replacing a Brush

Follow the standard EASYchange® process to change the brush. Provided that the Brush Health Sensor (BHS) still has battery life, the existing sensor-spring assembly can be reinstalled with the new brush.

Visit Cutsforth.com/BrushChange for video instructions.



REMINDER:

After the replacement brush is installed into the holder; short-press the BHS button one time, to reset the brush length data.

8.4. Brush Health Sensor Battery Life

The power source for the device is three Panasonic BR1632A lithium metal primary batteries soldered into the device. In the case of a low battery in a Brush Health Sensor, the Compact Brush Condition Monitoring System will display a low battery warning. At that point, the sensor will have roughly 30 days of battery life remaining.

Operational Battery Life: 2 Years (Will vary depending on user-defined measurement interval as well as operating environment)

8.5. Button-On Self Test

The Brush Health Sensor contains self-test logic that allows the user to perform a single button press on the sensor and receive a status code in the form of number of LED flashes.

LED Flashes	Status Code
1	Success
2	Battery voltage error
3	Accel comm error
4	Accel functional error
5	Magnetic encoder comm error
6	Temperature error
7	Application error

9. Using the cBCM System User Interface

Before powering the cBCM System on, first inspect the system to ensure that there are no foreign materials inside the enclosure, no damaged components, or loose wire connections.

9.1. Power On the cBCM System

To power on the cBCM System

1. Swing open the faceplate panel of the cBCM System.
2. Locate the switch towards the bottom of the panel and flip it to the "ON" position.
3. Close the faceplate panel and wait for the system to boot and automatically load the monitoring application.

9.2. cBCM System Screen Layout

The diagrams in this section illustrate how the cBCM System screen layout correlates to the brushes on your generator. The Advanced Configuration screen contains an option to select the generator reference label location. This allows the user to arrange the home screen in a way that makes the most sense for their unit configuration and the cBCM System mounting location.

This is the cBCM System screen layout. The below example shows the generator reference label location at the top of the screen.

1A		24	0.7	2A		22	0.7	3A		21	0.6	4A		21	0.7	5A		21	0.8	6A		21	0.7
100%				100%				82%				97%				100%				100%			
1B		20	0.6	2B		21	0.7	3B		20	0.6	4B		21	0.7	5B		20	0.8	6B		22	0.7
100%				89%				100%				100%				90%				92%			
1C		23	0.8	2C		19	0.7	3C		19	1.0	4C		21	0.7	5C		22	0.9	6C		21	0.7
85%				100%				84%				100%				100%				91%			
1D		23	0.7	2D		25	0.8	3D		19	0.6	4D		25	0.9	5D		21	0.9	6D		20	0.6
84%				98%				90%				100%				81%				84%			

Radio ON LEFT RIGHT Asset: 0000000000 - v3.50

The following diagrams show the brushes with the left (blue) and right (red) rows highlighted.

Generator Side



Generator Side

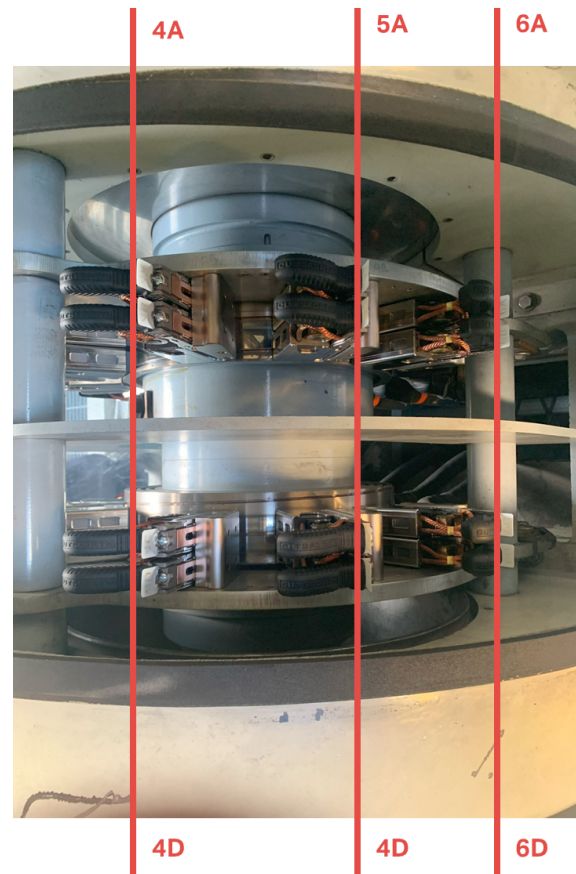

9.3. Navigating the cBCM System Screen

Once the cBCM System has been powered on, the top level view of the user interface screen appears:

- The **Config** button (A) opens the primary configuration window.
- Information in the top center of the user interface screen (B) shows plant name, generator manufacturer, name and type, and current time; all of which can be modified within Advanced Configuration.
- Asset tag and Compact Brush Condition Monitoring Application version are shown in the bottom right corner (C).

The screenshot displays the cBCM System Screen interface. At the top left is the CUTSFORTH logo. In the top center, there is a header area (B) containing: 'example plant', 'Siemens - example generator - example name', and '2022-08-17 12:51 PDT'. In the top right, there is a 'CONFIG' button (A). The main area is a table titled 'GENERATOR SIDE' with 24 columns (1A-6D) and 4 rows. Each cell in the table contains a percentage value. At the bottom left, it says 'Radio ON'. At the bottom right, there is an asset tag and version number (C): 'Asset: 0000000000 - v3.50'.

1A	24	0.7	2A	22	0.7	3A	21	0.6	4A	21	0.7	5A	21	0.8	6A	21	0.7
100%			100%			82%			97%			100%			100%		
1B	20	0.6	2B	21	0.7	3B	20	0.6	4B	21	0.7	5B	20	0.8	6B	22	0.7
100%			89%			100%			100%			90%			92%		
1C	23	0.8	2C	19	0.7	3C	19	1.0	4C	21	0.7	5C	22	0.9	6C	21	0.7
85%			100%			84%			100%			100%			91%		
1D	23	0.7	2D	25	0.8	3D	19	0.6	4D	25	0.9	5D	21	0.9	6D	20	0.6
84%			98%			90%			100%			81%			84%		

9.4. Power Off the cBCM System

To power off, repeat the power on sequence in reverse order.

Another option for power off is to:

1. Plug in an external USB keyboard.
2. Press **ALT+F4** to close out of the application.
3. Press **ALT+F4** again to bring up the Power menu.
4. Select your desired option (shut down, restart, etc.).
5. If shutting down, wait for the system to fully shut down, then open the faceplate panel and flip the switch to the OFF position.

10. Brush Status Indication

The individual brush status indicators provide the following information:

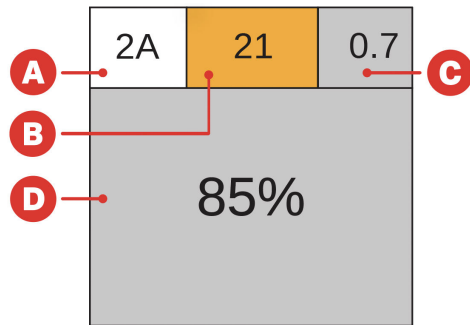

- A Location**
- B Temperature** (Peak Average in Degrees Celsius)
- C Brush Vibration/Displacement** (Mils Peak-to-Peak)
- D Usable Brush Life Remaining**

10.1. Color Definitions

The background color of the brush status indicator area changes depending on the remaining brush length:

- Red indicates the remaining brush length is less than or equal to 0%
- Pink indicates that the remaining brush length is less than or equal to the threshold set in the Configuration window

The background color of the displacement or temperature areas will be orange if the brush displacement or temperature value is greater than or equal to the associated threshold set in the Configuration window.

This figure shows possible background colors for different areas of the brush status indicator:

1A		2A		3A		4A		5A		6A	
22	0.6	21	0.7	20	0.9	21	0.8	22	0.6	19	0.5
100%		85%		100%		13%		95%		99%	
1B		2B		3B		4B		5B		6B	
21	0.6	21	0.7	20	0.6	19	0.7	21	0.7	21	0.7
91%		100%		100%		100%		-2%		81%	
						Low Battery				Low Battery	
1C		2C		3C		4C		5C		6C	
21	0.7	19	0.7	21	0.7	21	0.6	19	0.7	21	0.7
82%		49%		-2%		31%		29%		100%	
1D		2D		3D		4D		5D		6D	
24	0.7	21	0.6	21	0.7	19	0.9	21	0.6	21	0.7
100%		13%		28%		90%		92%		32%	
				Low Battery				Low Battery		Low Battery	

Radio ON

Asset 0000000000 - v3.50

11. Configure the Compact Brush Condition Monitoring System Settings

The following settings can be changed in the Configuration window:

- Brush Alert Length



At this level the location background color will change to pink.

- Displacement Fault Maximum



At this level the displacement background color will change to orange.

- Temperature Fault Maximum



At this level the temperature background color will change to orange.

To configure the Compact Brush Condition Monitoring System settings:

1. Press **Config (A)** to open the Configuration window.

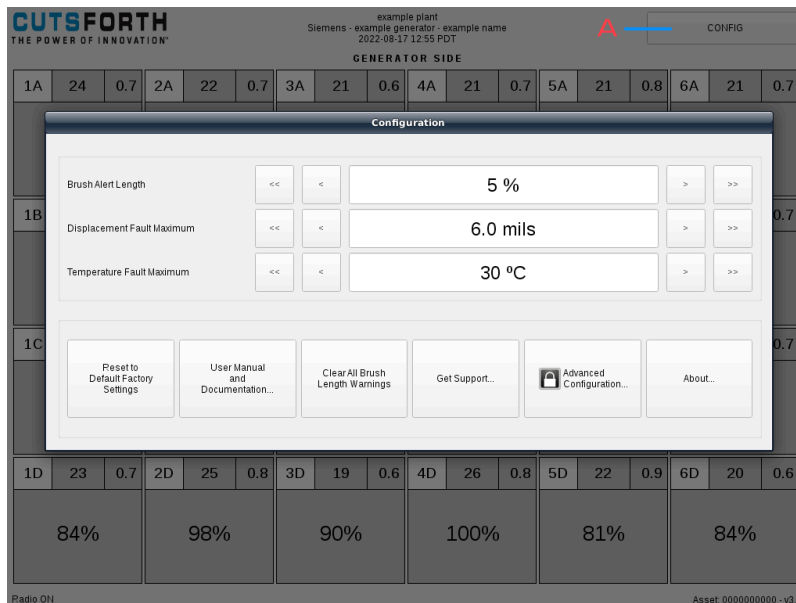

2. Click anywhere on the shaded area outside of the Configuration window to close it. If any settings have changed, a Save changes dialog appears.

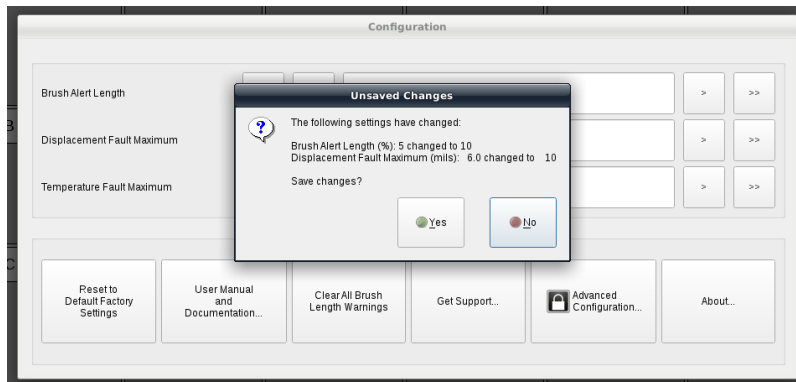

12. Advanced Configuration Settings



Some of the steps in these sections will require the use of a USB keyboard, USB mouse, and/or a USB storage drive. The use of a USB hub or splitter is often beneficial.

The Advanced Configuration window provides an option for the operator to:

- [Export Data and Event Logs \(page 37\)](#)
- [Update the Compact Brush Condition Monitoring Application \(page 38\)](#)
- [Update the Brush Health Sensor Firmware \(page 39\)](#)
- [Set the Compact Brush Condition Monitoring System Time \(page 40\)](#)

12.1. Access the Advanced Configuration Window

1. Press Config **(A)**.
2. Press Advanced Configuration **(B)**.

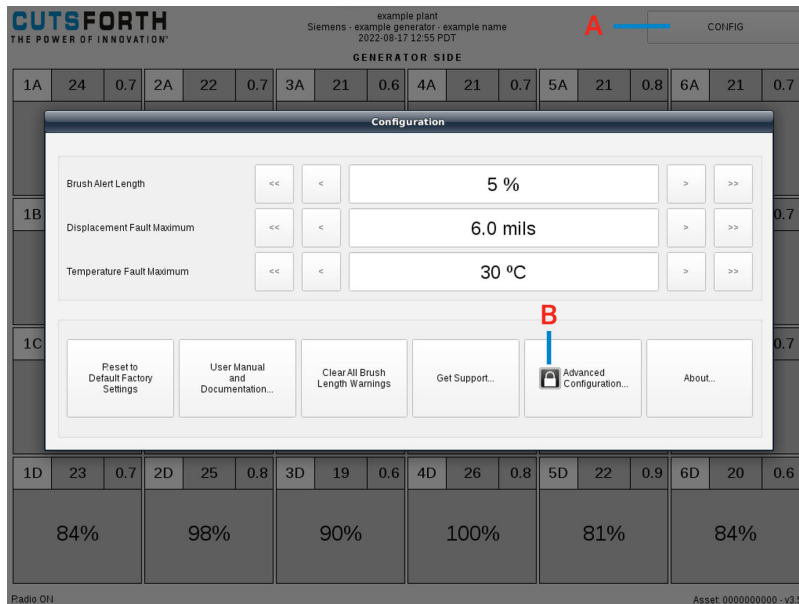

3. Enter the administrative password to open the Advanced Configuration window. Contact support@cutsforth.com for access information.

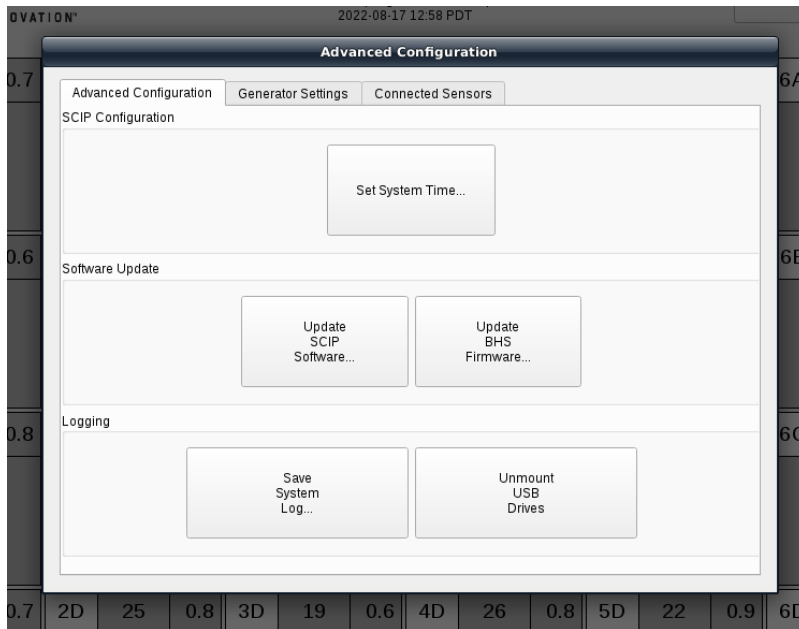

12.2. Export Data and Event Logs

1. Plug in a USB drive.
2. Press **Save System Log (A)**
3. Select the sdb1 folder **(B)**.
4. Press **Choose (C)**. This exports historical data logs to a .csv file and system event logs in the form of .txt files.

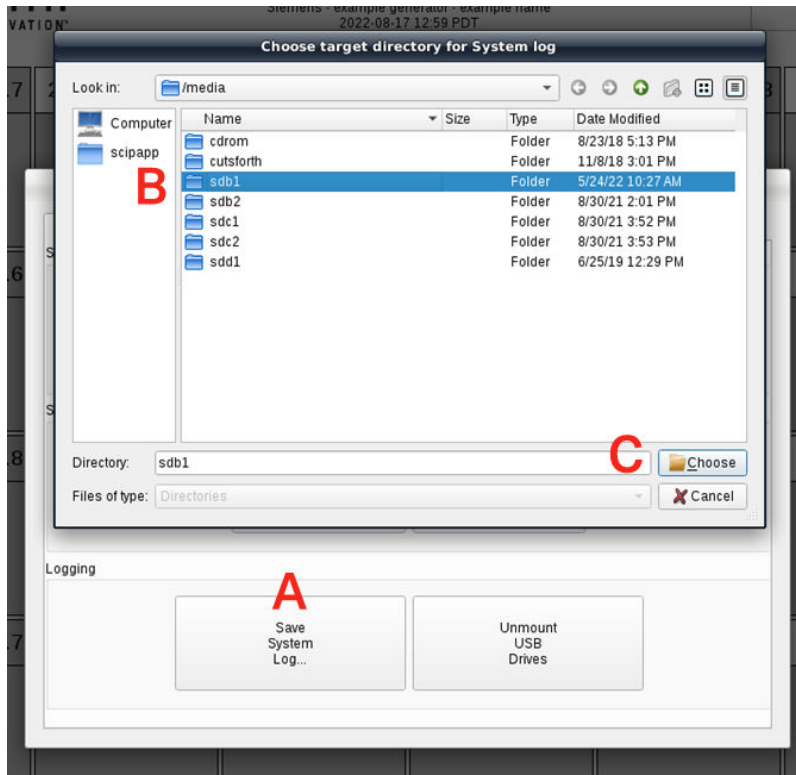

12.3. Update the Compact Brush Condition Monitoring Application

To update the Compact Brush Condition Monitoring Application utilizing an external USB device loaded with new software:

1. Plug in a USB drive with the new Compact Brush Condition Monitoring Application.
2. Press **Update SCIP Software (A)**.
3. Open the sdb1 folder and navigate to ScipApp binary.
4. Select **ScipApp binary (B)** and press **Open (C)**.
5. The Compact Brush Condition Monitoring Application will restart.

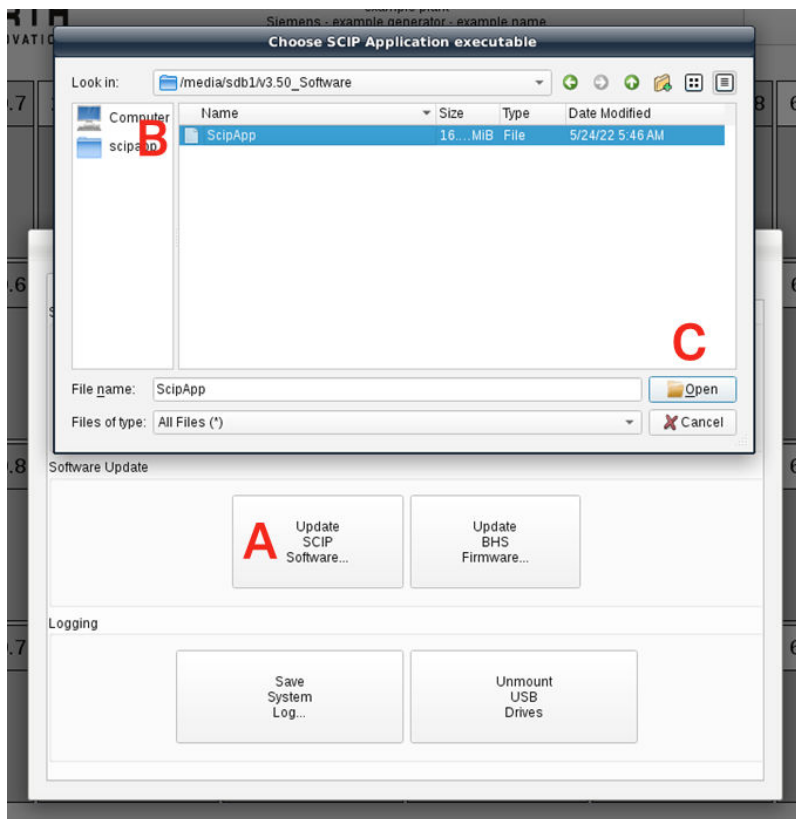

12.4. Update the Brush Health Sensor Firmware

To update the sensor firmware:

1. Plug in a USB drive with the new firmware.
2. Press **Update BHS Firmware (A)**.
3. Open the sdb1 folder and navigate to the latest firmware binary.
4. Select the firmware binary **(B)** and press **(C)**.
5. The application imports the new firmware and stages it for update.

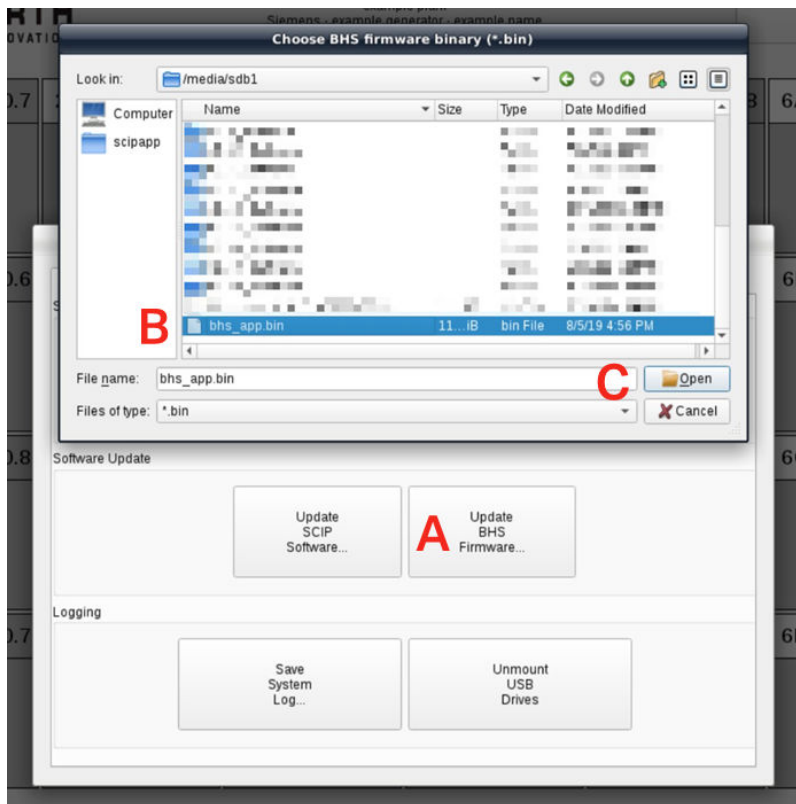

12.5. Set the Compact Brush Condition Monitoring System Time

To set the Compact Brush Condition Monitoring System time:

1. Press **Set System Time (A)**.
2. Press **Time Zone (B)**.



Automatic Time Zone must be turned off in order to manually set the time zone.

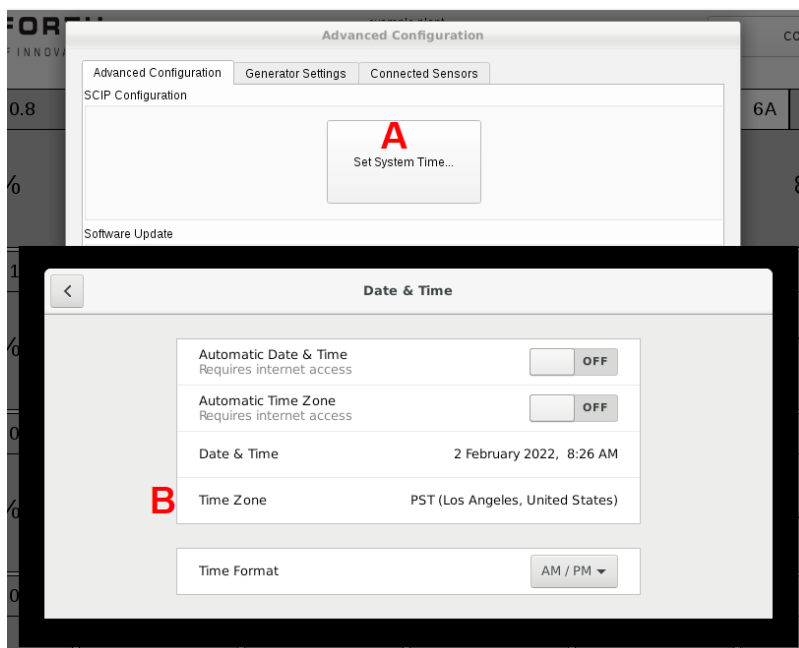

3. Select a time zone by pressing on the map or by entering a city name in the search bar and selecting from the drop-down list.

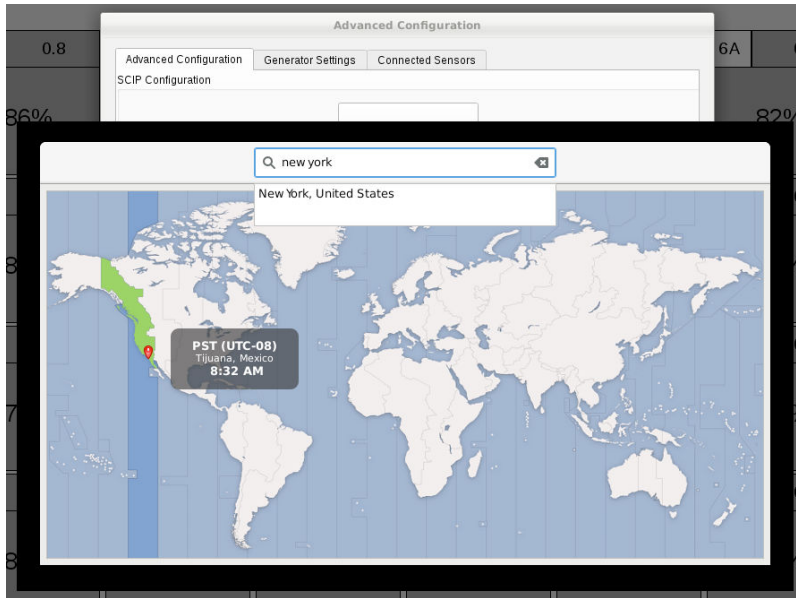

4. Press **Alt + F4** to close the Time Zone Selection window.
5. Press **Date and Time (C)**.



Automatic Date and Time must be turned off in order to manually set the date and time.

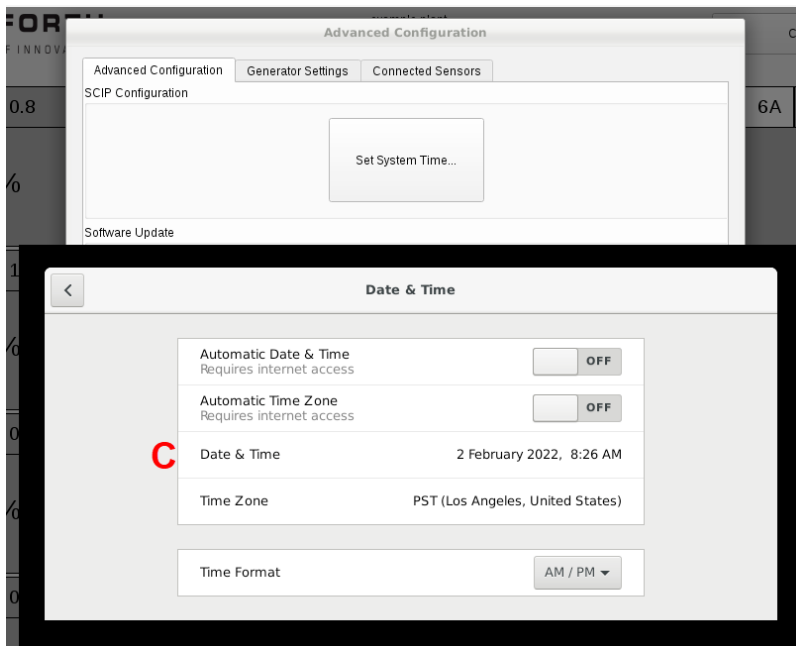

- Set the date and time and press the **Esc** key to close the date and time editor.

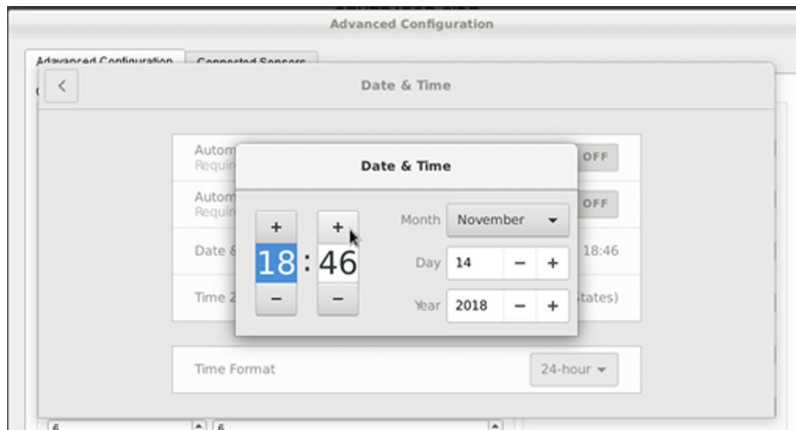

- Press **Alt + F4** to close the Date and Time window and return to the Advanced Configuration Window.
- Click anywhere on the shaded area outside of the Advanced Configuration window to close it.

13. Generator Settings

To access the Generator Settings page, enter the Advanced Configuration screen and navigate to the Generator Settings tab. The following settings can be changed from this page:

- Plant name
- Generator manufacturer, type, and name
- Location of on-screen generator reference label
- Measurement interval (how often sensors will report data)
- Number of brushes (number of rows and number of columns)
- Brush numbering label display type (alphanumeric vs. numeric)
- Modbus TCP port
- Modbus RTU serial interface settings



Some of the steps in these sections will require the use of a USB keyboard, USB mouse, and/or a USB storage drive. The use of a USB hub or splitter is often beneficial.

Advanced Configuration	
Generator Settings	
Connected Sensors	
Generator Information	
Plant	example plant
Generator Manufacturer	Siemens
Generator Type	example generator
Generator Name	example name
Generator Location	Top
Measurement Interval	1 hour
Num. Brush Rows	4
Num. Brush Columns	6
Label Display Type	Alphanumeric
Asset Tag	0000000000
Modbus - ttyS2 and ttyS3	
TCP Port	501
Server Address	1
Baud Rate	19200
Data Bits	8
Parity Bits	Even
Stop Bits	1
Re-Initialize Modbus Ports	

13.1. Measurement Interval

The Compact Brush Condition Monitoring System collects data sets from the Brush Health Sensors (BHS) during regular measurement intervals. This measurement interval is a user-configurable setting from the Generator Settings page with options of 1, 3, 6, or 12 hours. Please note that battery life of the BHS is directly impacted with the frequency of data collection.

The screenshot displays the 'Advanced Configuration' window with the 'Generator Settings' tab selected. The 'Generator Information' section includes fields for Plant (example plant), Generator Manufacturer (Siemens), Generator Type (example generator), Generator Name (example name), and Generator Location (Top). The 'Modbus - tyS2 and tyS3' section includes TCP Port (501), Server Address (1), Baud Rate (19200), Data Bits (8), Parity Bits (Even), and Stop Bits (1). A 'Re-initialize Modbus Ports' button is located at the bottom right. The 'Measurement Interval' dropdown menu is highlighted with a red box, showing options for 1 hour, 3 hours, 6 hours, and 12 hours. The '1 hour' option is currently selected.

14. Antenna Placement Mode



Sensor batteries will drain at a faster than normal rate during antenna placement mode.

To enter antenna placement mode, navigate to the Connected Sensors tab in the Advanced Configuration window and press **Antenna Placement Mode**.

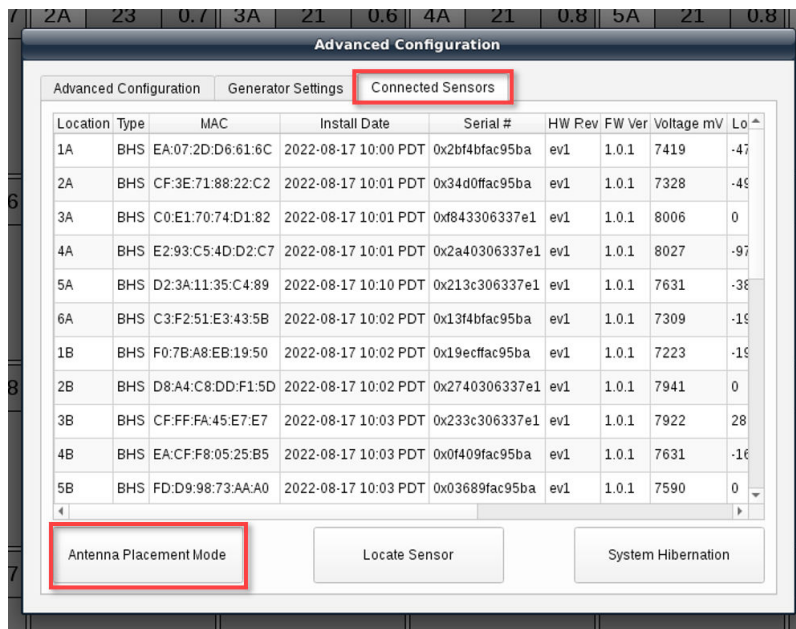

In antenna placement mode, brush status indicators show radio signal strength instead of sensor data. Background color changes depending on the strength of the radio signal:

- **Red:** Weak or unknown signal strength
- **Pink:** Moderate signal strength
- **Gray:** Strong signal strength

Two numbers are shown for every location:

- The left number is the signal strength on the Primary Controller side (quality of the radio link from sensor to the Primary Controller).
- The right number is the signal strength on the sensor side (quality of the radio link from Primary Controller to sensor).

Please allow around one hour for all sensors to report signal strength. To exit antenna placement mode, navigate back to the Connected Sensors tab in the Advanced Configuration window, and press **Antenna**

Placement Mode. To prevent excessive battery drainage, the cBCM system will automatically quit antenna placement mode after two hours.

example plant
 Siemens - example generator - example name
 2022-08-17 14:45 PDT

WARNING:
ANTENNA
PLACEMENT

CONFIG

GENERATOR SIDE

1A -54/-51	2A -52/-48	3A -53/-51	4A -53/-59	5A -50/-46	6A -60/-57
1B -53/-49	2B -53/-48	3B -50/-49	4B -47/-43	5B -53/-47	6B -58/-50
1C -59/-59	2C -54/-56	3C -57/-55	4C -54/-49	5C -50/-43	6C -49/-45
1D -50/-44	2D -49/-44	3D -57/-55	4D -54/-55	5D -54/-55	6D -50/-43

Radio ON
Asset: 0000000000 - v3.50

15. Modbus Interface

To convert the alphanumeric brush location tags to a numeric value that corresponds to the Modbus outputs, use the following schema: From smallest to largest: 1A, 2A, 3A,..., 1B, 2B, 3B,..., 1C, 2C, 3C, etc.



The Compact Brush Condition Monitoring System should be configured as a slave device.

Refer to this table when programming the Modbus output on your cBCM System:

Brush	Name	Value Type	Value Unit	Register Type	Address (Base 0)	Physical Address (Base 0)	Supported Functions
0–229	Sensor Low Batt	Boolean	Flag	Discrete Input	10000–10229	0x000–0x0E5	0x02 Read Discrete Input
0–229	Sensor Malfunction	Boolean	Flag	Discrete Input	10230–10459	0x0E6–0x1CB	0x02 Read Discrete Input
0–229	Replace Brush Now (Critical)	Boolean	Flag	Discrete Input	10460–10659	0x1CC–0x2B1	0x02 Read Discrete Input
0–229	Replace Brush Soon (Alert)	Boolean	Flag	Discrete Input	10690–10919	0x2B2–0x397	0x02 Read Discrete Input
0–229	High Vibration Warning	Boolean	Flag	Discrete Input	10920–11149	0x398–0x47D	0x02 Read Discrete Input
0–229	Sensor Sample Old	Boolean	Flag	Discrete Input	11150–11379	0x47E–0x563	0x02 Read Discrete Input
0–229	Temperature Critical	Boolean	Flag	Discrete Input	11380–11609	0x564–0x649	0x02 Read Discrete Input
0–229	Length Error	Boolean	Flag	Discrete Input	11610–11839	0x64A–0x72F	0x02 Read Discrete Input
0–229	Brush Length	Short	% Remaining	Input Register	30000–30229	0x000–0x0E5	0x04 Read Input Register
0–229	Pk-to-Pk Displacement	Word	0.001 mils	Input Register	30230–30459	0x0E6–0x1CB	0x04 Read Input Register
0–229	Temperature	Short	Degrees C	Input Register	30460–30689	0x1CC–0x2B1	0x04 Read Input Register
N/A	System Status	Word	Bitfield: b0 : Hibernation Mode (1 - Enabled, 0 - Disabled) b1-15: RFU	Input Register	30920	0x398	0x04 Read Input Register
N/A	System Time	Word	POSIX time (LSB - MSB)	Input Register	30921–30922	0x399–0x39A	0x04 Read Input Register
N/A	Short Brush Count	Word	Number of brushes that must be replaced immediately	Input Register	30923	0x39B	0x04 Read Input Register

Brush	Name	Value Type	Value Unit	Register Type	Address (Base 0)	Physical Address (Base 0)	Supported Functions
N/A	Near-Short Brush Count	Word	Number of brushes that will need replacement soon	Input Register	30924	0x39C	0x04 Read Input Register
N/A	High Vibration Brush Count	Word	Number of sensors reporting high vibration	Input Register	30925	0x39D	0x04 Read Input Register
N/A	Sensor Error Count	Word	Number of sensors reporting errors	Input Register	30926	0x39E	0x04 Read Input Register
N/A	Low Battery Total	Word	Number of sensors reporting low battery	Input Register	30927	0x39F	0x04 Read Input Register
0–229	Battery Voltage	Word	Millivolts (mV)	Input Register	30928–31157	0x3A0–0x485	0x04 Read Input Register
0–229	RSSI Value	Word	Decibel milliwatts (dBm)	Input Register	31158–31387	0x486–0x56B	0x04 Read Input Register
0–229	BHS MAC address (lo byte, little-endian)	Word	N/A	Input Register	31388–31617	0x56C–0x651	0x04 Read Input Register
0–229	BHS MAC address (mid byte, little endian)	Word	N/A	Input Register	31618–31847	0x652–0x737	0x04 Read Input Register
0–229	BHS MAC address (hi byte, little-endian)	Word	N/A	Input Register	31848–32077	0x738–0x81D	0x04 Read Input Register
0–229	SensorError Register with Sensor Error Flags	Word	N/A	Input Register	32078–32307	0x81E–0x903	0x04 Read Input Register
N/A	Old Samples Count	Word	Number of sensors reporting old samples	Input Register	32308	0x904	0x04 Read Input Register
N/A	Temperature Critical Count	Word	Number of sensors reporting critical temperature	Input Register	32309	0x905	0x04 Read Input Register

Brush	Name	Value Type	Value Unit	Register Type	Address (Base 0)	Physical Address (Base 0)	Supported Functions
N/A	Length Error Count	Word	Number of sensors reporting brush length errors	Input Register	32310	0x906	0x04 Read Input Register

15.1. Entering a Static IP Address

1. Plug the USB keyboard into the cBCM system.
2. Press **Alt+F2** to pull up the Application Finder.

The screenshot shows the Cutsforth monitoring interface. At the top, it displays 'example plant', 'Siemens - example generator - example name', and '2022-08-17 13:15 PDT'. A 'CONFIG' button is in the top right. The main area is a 'GENERATOR SIDE' grid with columns for units 1A through 6D. Each unit cell contains three small values (e.g., 25, 0.7) and a large percentage value (e.g., 100%). An 'Application Finder' window is open in the center, showing a search bar and a green arrow icon on the right side of the search bar.

1A	25	0.7	2A	23	0.7	3A	21	0.6	4A	21	0.8	5A	21	0.8	6A	21	0.7
100%			100%			82%			100%			100%			100%		
1B	20	0.6	2B	21	0.7	3B	20	0.6	4B	21	0.7	5B	20	0.8	6B	22	0.7
100%												92%					
1C	23	0.8	2C	23	0.8	3C	23	0.8	4C	23	0.8	5C	23	0.8	6C	21	0.7
85%			100%			84%			100%			100%			91%		
1D	23	0.7	2D	25	0.8	3D	19	0.6	4D	26	0.8	5D	22	0.9	6D	21	0.6
84%			98%			90%			100%			81%			84%		

Radio ON Asset: 0000000000 - v3.50

3. Click on the green arrow that is pointed down to display the window of options.

This screenshot is similar to the previous one, but the 'Application Finder' window is now open, displaying a list of system options. The list includes: 'All Applications', 'Bookmarks', 'Commands History', 'Accessories', 'Education', 'Games', 'Graphics', 'Internet', 'Multimedia', 'Office', 'Settings', 'Preferences', 'About Xfce', 'Accessibility', 'Additional Drivers', 'Appearance', 'Application Finder', 'Archive Manager', 'Brasero', and 'Browse'. A green arrow icon is visible at the top right of the window's search bar.

1A	25	0.7	2A	23	0.7	3A	21	0.6	4A	21	0.8	5A	21	0.8	6A	21	0.7
100%			100%			82%			100%			100%			100%		
1B	20	0.6	2B	21	0.7	3B	20	0.6	4B	21	0.7	5B	20	0.8	6B	22	0.7
100%												92%					
1C	23	0.8	2C	23	0.8	3C	23	0.8	4C	23	0.8	5C	23	0.8	6C	21	0.7
85%			100%			84%			100%			100%			91%		
1D	23	0.7	2D	25	0.8	3D	19	0.6	4D	26	0.8	5D	22	0.9	6D	21	0.6
84%			98%			90%			100%			81%			84%		

Radio ON Asset: 0000000000 - v3.50

4. Scroll down, select **Network Connections**, and click **Launch**.



5. Double-click **Wired Connection 1**.

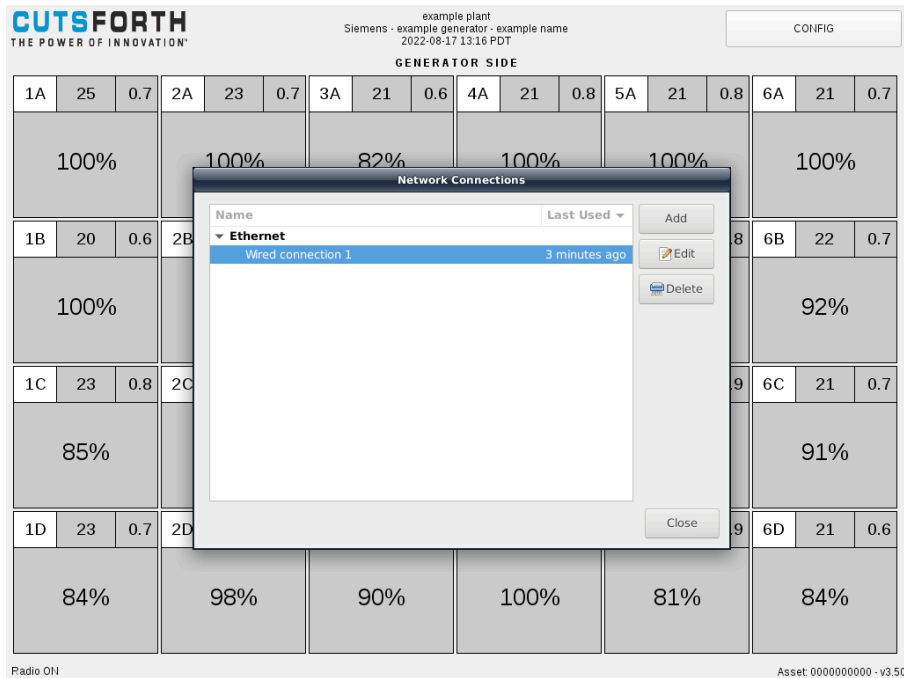

- Select the **IPv4 Settings** tab.

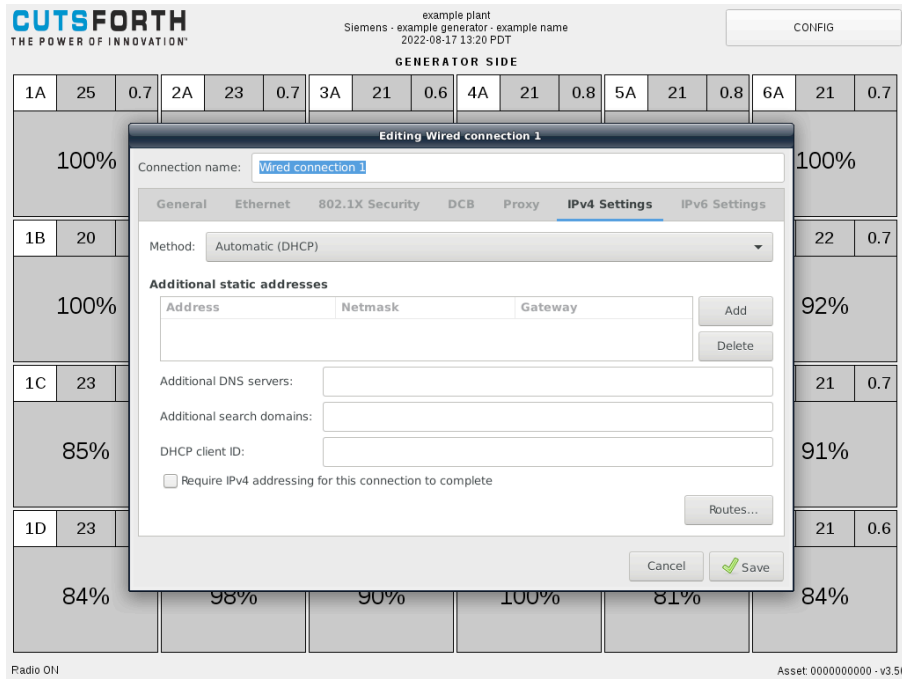

- Under the Method drop-down, select **Manual** to change IP configuration settings to **static**.

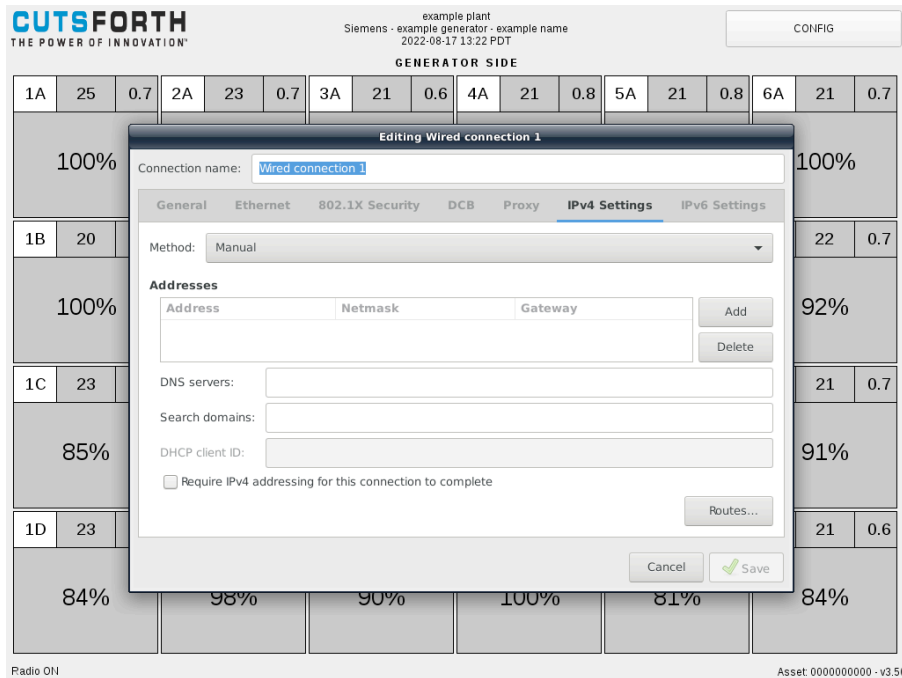

8. Click **Add**.

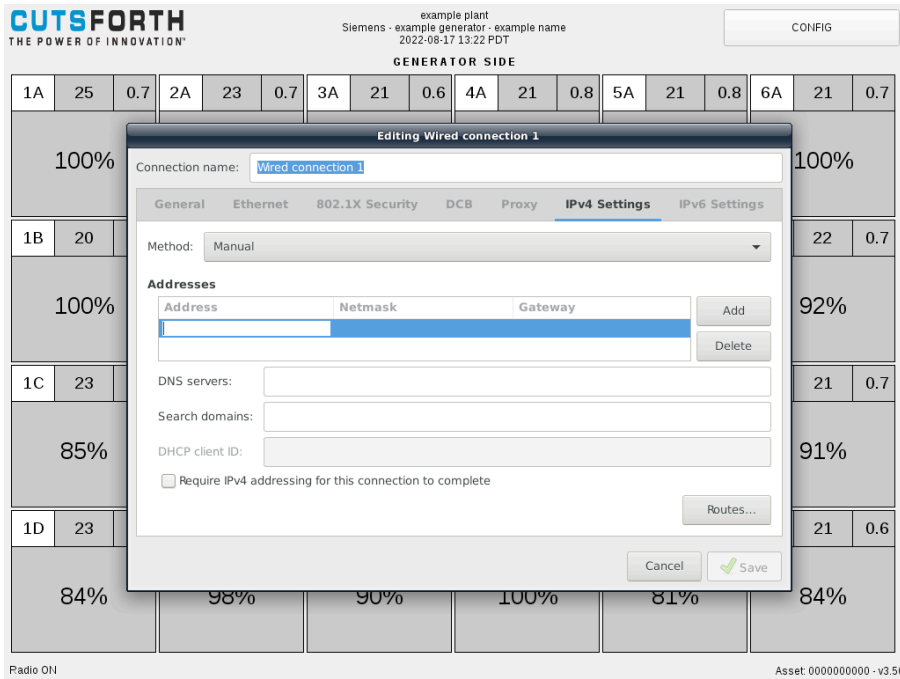

9. Enter the desired addressing information, and click **Save** when you are finished.

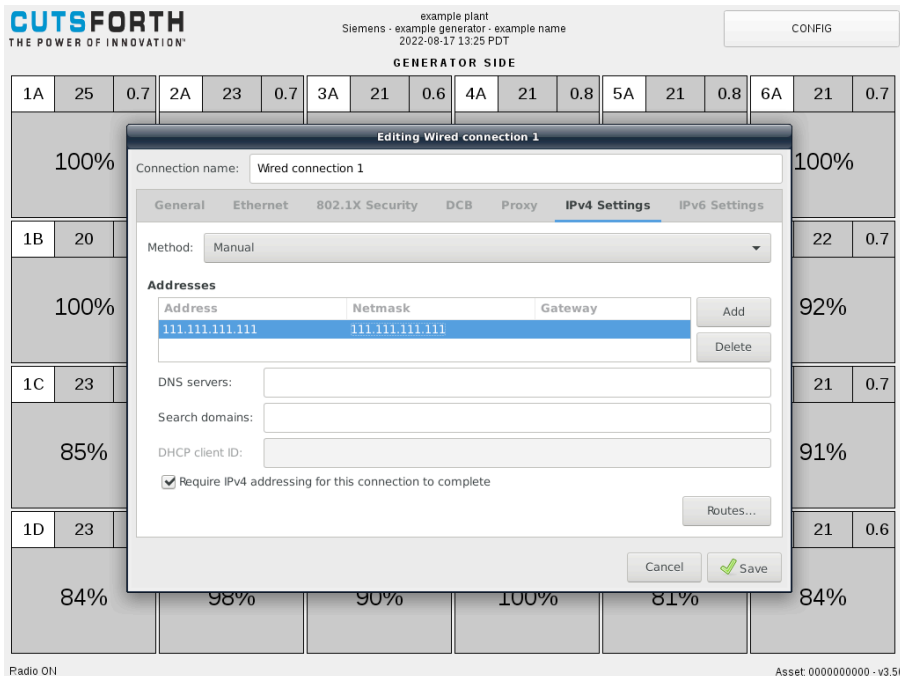

15.2. Locating the MAC Addresses

1. Connect a USB keyboard to the cBCM system.
2. From the cBCM Application Home Screen, press **CONFIG** in the upper-right corner.

GENERATOR SIDE																	
1A	24	0.7	2A	22	0.7	3A	21	0.6	4A	21	0.7	5A	21	0.8	6A	21	0.7
100%			100%			82%			97%			100%			100%		
1B	20	0.6	2B	21	0.7	3B	20	0.6	4B	21	0.7	5B	20	0.8	6B	22	0.7
100%			89%			100%			100%			90%			92%		
1C	23	0.8	2C	19	0.7	3C	19	1.0	4C	21	0.7	5C	22	0.9	6C	21	0.7
85%			100%			84%			100%			100%			91%		
1D	23	0.7	2D	25	0.8	3D	19	0.6	4D	25	0.9	5D	21	0.9	6D	20	0.6
84%			98%			90%			100%			81%			84%		

Radio ON Asset: 0000000000 - v3.50

3. At the bottom of the Configuration screen, press **Advanced Configuration**. When prompted, enter the administrative password.

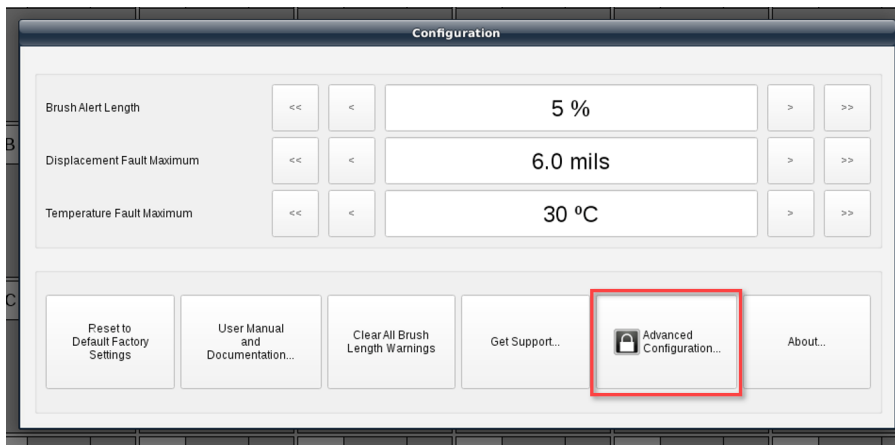

4. In the lower-right corner of the Advanced Configuration screen, press **Set System Time**.

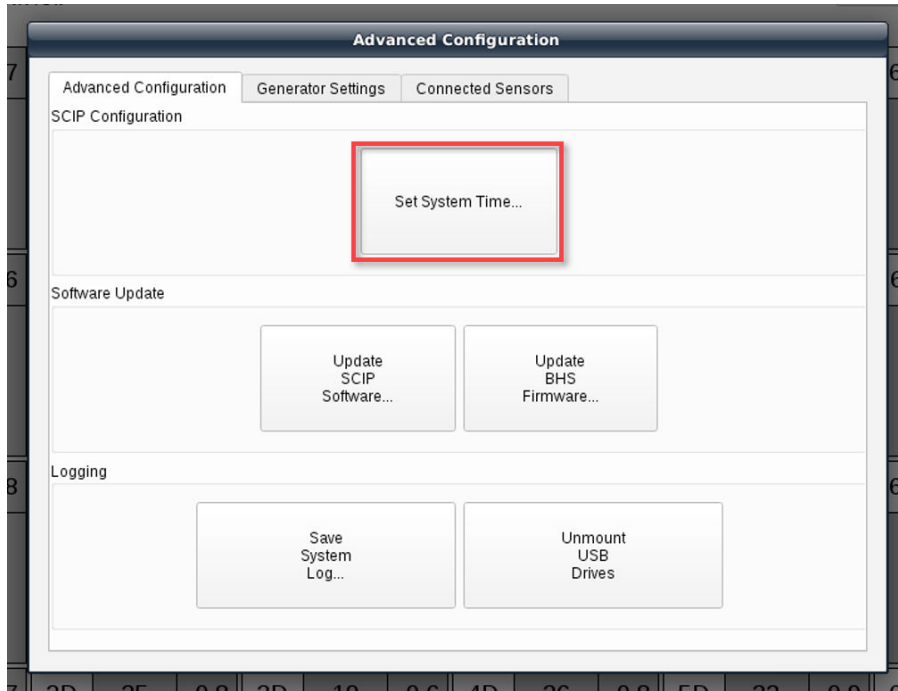

5. From the Data & Time screen, press the back button in the upper-left corner.

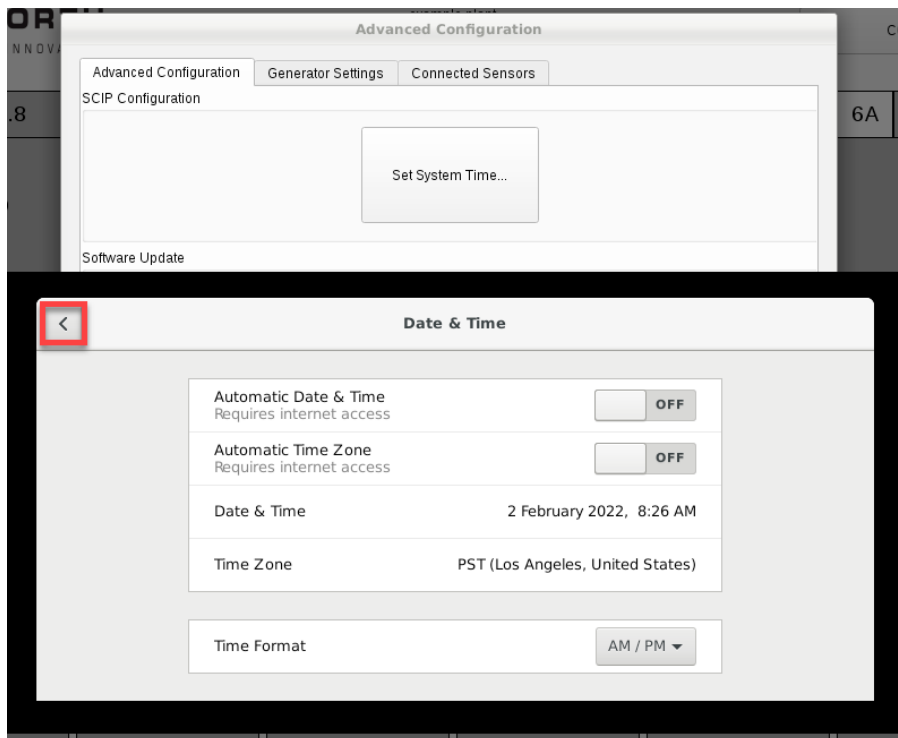

- From the All Settings menu, select **Network**.

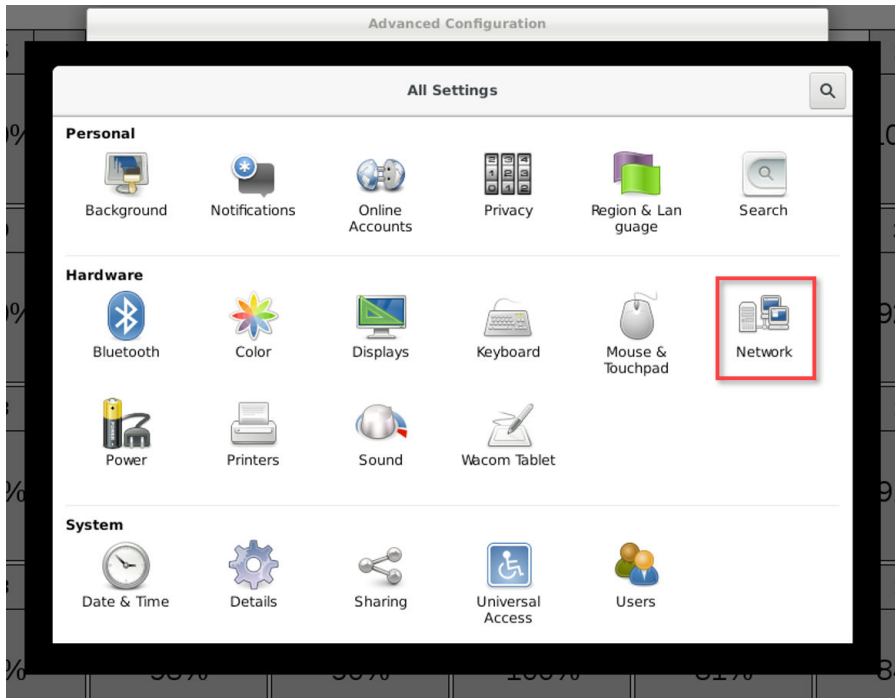

- The MAC addresses will be listed as "Hardware Address" under each "Ethernet" option in the list on the left hand side.

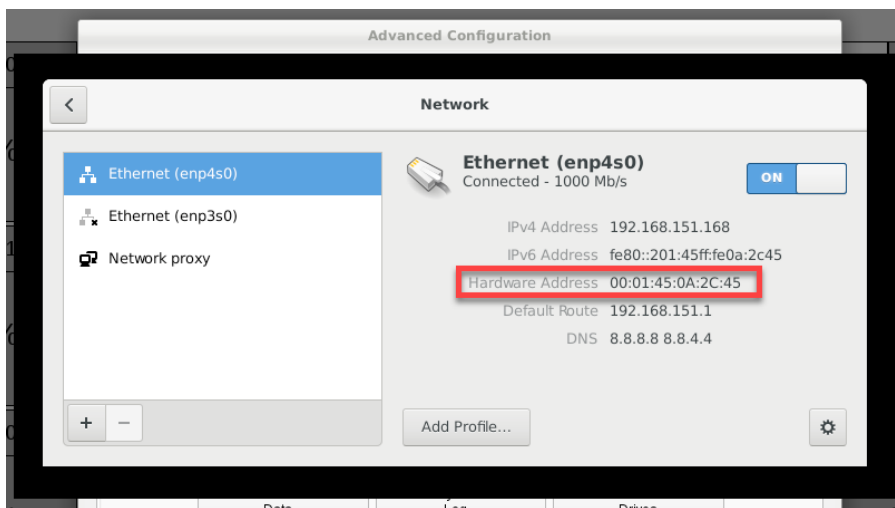

15.3. Modbus RTU Configuration

In addition to Modbus TCP/IP, the cBCM System also supports Modbus RTU communication via either RS-232 or RS-485. If using Modbus RTU, confirm the serial ports are configured appropriately for either RS-232 or RS-485. This can be managed in the SIO Configuration settings within the BIOS menu. The BIOS menu can be accessed by pressing F2 during the bootup process.

A null modem cable is required if using RS-232.

The cBCM System provides an DB9 connection point for the Modbus RTU communications. The following table outlines the wiring pinouts for RS-232 and RS-485.

DB9 Pin	RS-232	RS-485
1	DCD	N/A
2	Rx	Tx/Rx +
3	Tx	N/A
4	DTR	N/A
5	GND	GND
6	DSR	Tx/Rx -
7	RTS	N/A
8	CTR	N/A
9	RI	N/A

16. Frequently Asked Questions (FAQ)

How can I confirm if a sensor is already paired and where it is paired to?

Return to the main screen of the controller, single-press the button on the BHS sensor in question and that sensor's brush location icon will flash with a blue border for a few seconds. If none of the brush location icons flash, that sensor is not paired to any of the brush location icons.

Can a new BHS be installed on a used brush?

Yes, both a new BHS and a used BHS with battery life remaining can be installed on new and partially used brushes alike. Remember, in both cases, to single-press the sensor button after the sensor and brush are installed in the holder, but before it is installed onto the generator, to reset the brush length data.

How long does a BHS battery last?

The expected battery life of the sensors is 2 years or longer and may vary depending on environmental conditions and the user-set measurement intervals. The brush location icon will show a low battery warning roughly 30 days prior to the end of the BHS battery life.

What is the "Clear Brush Length Warnings" button on the brush detail screen for?

When a brush length falls below the threshold set in the CONFIG screen, that brush data icon will turn pink, and then red if it falls below 0%. If the brush length is no longer below the user-set threshold, but the pink/red condition still persists, pressing this button will reset the icon back to gray.

What do the different color warnings mean in the Brush Data Icon?

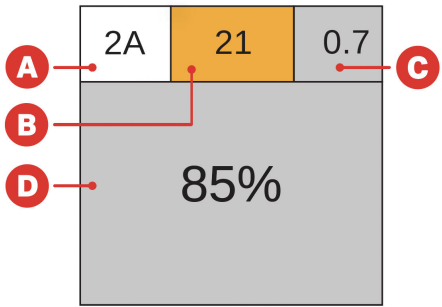
 <p>A Location B Temperature (Peak Average in Degrees Celsius) C Brush Vibration/Displacement (Mils Peak-to-Peak) D Usable Brush Life Remaining</p>	<p>Section C will turn orange when the vibration/displacement threshold is exceeded, which is set in the CONFIG screen under "Displacement Fault."</p> <p>Section D will turn pink when the usable brush life goes below the "Brush Alert Length" threshold, also set in the CONFIG screen. Then this section will turn red once the brush exceeds its usable life (0%).</p>
--	--

What do I do if I see "No Data" on a brush location icon?

Attempt the following troubleshooting steps in this order:

1. Press the button on the associated sensor once, and watch the cBCM screen to see if the location in question updates with data within a few seconds.
2. Unpair and re-pair the BHS following the instructions under Pairing a Brush Health Sensor, then wait for the measurement interval to pass (default is three hours) to see if the location begins showing data.

If steps 1-2 are not successful, please submit a support request at Cutsforth.com/Support.

What does the  symbol on the brush location icon mean?

The  symbol indicates that attention is needed on that brush location, though it can mean a number of different things, from an abnormal brush length reading to a sensor not being connected to the cBCM System. Clicking on the brush location icon can yield some information about this alert in some cases, but for the most detailed information, you can export the system logs (see section 13.2). If the alert is associated with a condition that is no longer present, pressing the "Clear Brush Length Warnings" button on the brush details screen will clear this alert.

17. Glossary

antenna	A device, typically mounted inside the exciter enclosure, which helps facilitate wireless communications between the Compact Brush Condition Monitoring System and the Brush Health Sensors.
antenna placement mode	An optional mode included in the Compact Brush Condition Monitoring System which displays the wireless signal strength of each sensor in order to assist in successful placement of the antenna.
attenuation	The reduction of the amplitude of a signal due to excessive cable length.
AWG	American Wire Gauge
Brush Health Sensor (BHS)	A wireless sensor integrated into the brush spring which communicates with the Compact Brush Condition Monitoring System.
Compact Brush Condition Monitoring System	A Cutsforth EASYchange® monitoring system that performs automated measurements and brush health analytics that allow plant operators to improve the efficiency of technicians' daily and weekly tasks by dispatching them to the collector when maintenance is actually needed.
DCS	Distributed Control System
LOTO	Lockout/Tagout
Modbus RTU	Modbus Remote Terminal Unit
Modbus TCP	Modbus Transmission Control Protocol