

## Installation Planning Guide EZDP-2056 Rev H

Electromagnetic Interference (EMI) Monitoring



## Table of Contents

1. About Cutsforth .....	4
1.1. Cutsforth Products .....	4
1.2. Cutsforth Field Services .....	4
1.3. Cutsforth Automation and Control Services .....	4
2. Legal Information .....	5
2.1. Limited Warranty .....	5
2.2. Copyright .....	6
2.3. Patents .....	6
3. Safety Information .....	7
3.1. Safety Information [English] .....	7
3.1.1. Safety Conventions .....	7
3.1.2. General Safety Instructions .....	7
3.2. Consignes de Sécurité [Français] .....	8
3.2.1. Conventions de Sécurité .....	8
3.2.2. Consignes de Sécurité Générales .....	9
4. Introduction .....	10
5. Equipment List .....	11
6. Planning the Electromagnetic Interference (EMI) Monitoring Installation .....	12
6.1. Planning the Layout .....	12
6.2. Planning the Current Transformer (CT) Locations .....	12
6.2.1. Option 1: Generator Neutral Ground Transformer (NGT) .....	12
6.2.2. Option 2: Generator Step Up (GSU) Transformer .....	14
6.2.3. Option 3: Potential Transformer Casing Ground .....	16
6.2.4. Option 4: Generator Frame Ground .....	17
7. Installation .....	18
7.1. Conduit Layout .....	18
7.1.1. Conduit Layout for Painted or Stainless Steel Enclosure .....	18
7.1.2. Conduit Layout for Optional Legacy Configuration .....	20
7.2. Conduit and Strut Channel Recommendations .....	21
7.2.1. Recommended Strut Rack Design .....	21
8. Technical Specifications .....	22
8.1. Painted Steel Enclosure .....	22
8.2. Stainless Steel Enclosure .....	23
8.3. Optional Legacy Configuration .....	25
8.3.1. Main Enclosure .....	25
8.3.2. Power Supply Enclosure .....	26
8.4. Approved Manufacturing Locations .....	27
8.5. Product Certifications .....	27
8.6. Environmental Requirements .....	28
8.7. AC Power Supply Requirements .....	28
8.8. AC Power Specifications .....	28
8.9. DC Power Input Specifications .....	28
8.10. Electromagnetic Compatibility .....	29
9. Integration and Infrastructure .....	30
10. Responsibilities .....	31
10.1. Planning Phase .....	31
10.2. Preparation for Service Phase .....	31

10.3. Cutsforth Service Phase – Cutsforth Technicians On-site .....	31
10.4. InsightCM Phase .....	32
11. Glossary .....	33

# 1. About Cutsforth

Cutsforth specializes in developing innovative new technologies and services to support the power generation industry. Cutsforth's patented EASYchange® brush holder design, online truing service, InsightCM™ condition monitoring software, and patented shaft grounding and monitoring systems have been installed across the globe in generators of all sizes and in nearly every industry application, including nuclear, natural gas, coal, wind, and hydroelectric.

Cutsforth's knowledge and commitment to excellence drives our innovative solutions for the changing needs of the power industry. Whether it is a quick response to a critical situation or a new way of solving an old problem, our commitment to quality ensures that our customers receive best-in-class products and services—Cutsforth is the Power of Innovation.

Cutsforth started back in 1991 as a small company focused primarily on making replacement brush holders for generators and exciters. Today, after 30+ years in business, Cutsforth's experience and innovative designs have brought its best-in-class excitation brush holder and shaft grounding replacements and collector ring services to some of the world's largest power companies.

## 1.1. Cutsforth Products

- [EASYchange® Removable Brush Holders](#)
- [EASYchange® Brush Condition Monitoring](#)
- [Cutsforth Shaft Grounding Systems](#)
- [Rotor Flux Monitoring](#)
- [Electro-Magnetic Interference Monitoring](#)
- [InsightCM™ Condition Monitoring Software](#)

## 1.2. Cutsforth Field Services

Cutsforth provides comprehensive product installations for all product offerings as well as on-site training after the installation. We work efficiently during your outage to ensure a smooth upgrade to our innovative solutions such as Product Installations, Online Collector Ring and Commutator Truing, Spiral Groove Restoration, and Consulting and Emergency Services.

## 1.3. Cutsforth Automation and Control Services

Cutsforth provides comprehensive Automation and Control services which include data historian integration, InsightCM™ integration, DCS logic, engineered drawings and much more. This further complements our turnkey monitoring system installations.

## 2. Legal Information

### 2.1. Limited Warranty

This document is provided 'as is' and is subject to being changed, without notice, in future editions. Cutsforth reviews this document carefully for technical accuracy; however, CUTSFORTH MAKES NO EXPRESS OR IMPLIED WARRANTY AS TO THE ACCURACY OF THE INFORMATION WITHIN THIS MANUAL AS IT RELATES TO SPECIFIC INSTALLATION. THE CUSTOMER IS RESPONSIBLE FOR VERIFYING INSTALLATION AND OPERATING CONDITIONS AT EACH INSTALLATION LOCATION AND FOR EACH GENERATOR TYPE. Cutsforth warrants that its hardware products will be free of defects in materials and workmanship that cause the product to fail to substantially conform to the applicable Cutsforth published specifications for one (1) year from the date of invoice.

For a period of ninety (90) days from the date of invoice, Cutsforth warrants that (i) its software products will perform substantially in accordance with the applicable documentation provided with the software, and (ii) the software media will be free from defects in materials and workmanship. If Cutsforth receives notice of a defect or non-conformance during the applicable warranty period, Cutsforth will, in its discretion: (i) repair or replace the affected product, or (ii) refund the fees paid for the affected product. Repaired or replaced hardware will be warranted for the remainder of the original warranty period or ninety (90) days, whichever is longer. If Cutsforth elects to repair or replace the product, Cutsforth may use new or refurbished parts or products that are equivalent to new in performance and reliability and are at least functionally equivalent to the original part or product. You must obtain an RMA number from Cutsforth before returning any product to Cutsforth. Cutsforth reserves the right to charge a fee for examining and testing hardware not covered by the Limited Warranty.

This Limited Warranty does not apply if the defect of the product resulted from improper or inadequate maintenance, installation, repair, or calibration performed by a party other than Cutsforth; unauthorized modification; improper environment; use of an improper hardware or software key; improper use or operation outside of the specification for the product; improper voltages; accident, abuse, or neglect; or a hazard such as lightning, flood, or other act of nature.

THE REMEDIES SET FORTH ABOVE ARE EXCLUSIVE AND THE CUSTOMER'S SOLE REMEDIES, AND SHALL APPLY EVEN IF SUCH REMEDIES FAIL OF THEIR ESSENTIAL PURPOSE.

WARNING REGARDING USE OF CUTSFORTH SHAFT MONITORING EQUIPMENT: CUSTOMER IS ULTIMATELY RESPONSIBLE FOR VERIFYING AND VALIDATING THE SUITABILITY AND RELIABILITY OF THE PRODUCTS WHENEVER THE PRODUCTS ARE INCORPORATED IN THEIR SYSTEM OR APPLICATION, INCLUDING THE APPROPRIATE DESIGN, PROCESS, AND SAFETY LEVEL OF SUCH SYSTEM OR APPLICATION. PRODUCTS ARE NOT DESIGNED, MANUFACTURED, OR TESTED FOR USE IN LIFE OR SAFETY CRITICAL SYSTEMS, OR ANY OTHER APPLICATION IN WHICH THE FAILURE OF THE PRODUCT OR SERVICE COULD LEAD TO DEATH, PERSONAL INJURY, SEVERE PROPERTY DAMAGE OR ENVIRONMENTAL HARM (COLLECTIVELY, "HIGH-RISK USES"). FURTHER, PRUDENT STEPS MUST BE TAKEN TO PROTECT AGAINST FAILURES, INCLUDING PROVIDING BACK-UP AND SHUT-DOWN MECHANISMS. CUTSFORTH EXPRESSLY DISCLAIMS ANY EXPRESS OR IMPLIED WARRANTY OF FITNESS OF THE PRODUCTS OR SERVICES FOR HIGH-RISK USES.

CUTSFORTH DOES NOT WARRANT, GUARANTEE, OR MAKE ANY REPRESENTATIONS REGARDING THE USE OF OR THE RESULTS OF THE USE OF THE PRODUCTS IN TERMS OF CORRECTNESS, ACCURACY, RELIABILITY, OR OTHERWISE. CUTSFORTH DOES NOT WARRANT THAT THE OPERATION OF THE PRODUCTS WILL BE UNINTERRUPTED OR ERROR FREE. INCIDENTAL AND CONSEQUENTIAL DAMAGES, INCLUDING LOSS OF USE, ARE SPECIFICALLY EXCLUDED FROM THIS WARRANTY; THE MAXIMUM VALUE OF A WARRANTY CLAIM CANNOT EXCEED THE ORIGINAL VALUE OF THE ASSEMBLY OR COMPONENT.

## 2.2. Copyright

Under copyright law, this publication may not be reproduced or transmitted in any form, electronic or mechanical, including photocopying, recording, storing in an information retrieval system, or translating, in whole or in part, without the prior written consent of Cutsforth. Cutsforth respects the intellectual property of others, and we ask our users to do the same. Cutsforth software is protected by copyright and other intellectual property laws. Cutsforth software is only licensed to be run on the intended hardware for which it was purchased. Reproduction of software or written materials is prohibited unless Customer has obtained a license for that express purpose.

## 2.3. Patents

Please send patent information requests to [patents@cutsforth.com](mailto:patents@cutsforth.com).

## 3. Safety Information

### 3.1. Safety Information [English]

Following is important safety information. For safe installation and operation of this equipment, be sure to read and understand all cautions and warnings.

#### 3.1.1. Safety Conventions



##### NOTE:

Additional information.



##### ELECTRICAL DANGER

Indicates an action or specific equipment area that can result in personal injury or death from an electrical hazard if proper precautions are not taken.



##### CAUTION

Indicates a hazardous situation that, if not avoided, could result in minor or moderate injury or equipment damage.



##### WARNING

Indicates a hazardous situation that, if not avoided, could result in death or serious injury.



##### ROTATING PART CAUTION

Indicates possible injury from rotating parts.



##### DANGER

Indicates a hazardous situation that, if not avoided, will result in death or serious injury.

#### 3.1.2. General Safety Instructions



##### ELECTRICAL DANGER

Only qualified personnel who recognize shock hazards and are familiar with the safety precautions required to avoid injury should work with Cutsforth products. Among the many considerations are the following:

- Avoid contact with energized circuits.
- Avoid contact with rotating parts.
- Never install any component that appears not to be functioning in a normal manner.
- Always ensure proper installation of the holder assembly and shaft grounding rope.



### ELECTRICAL DANGER

Before working on the generator, de-energize, lock out, and tag out all power sources to the generator, shaft, and accessory devices. Electric shock and death may result due to failure to heed this warning.



### ROTATING PART CAUTION

High-voltage and rotating parts can cause serious or fatal injury. Installation, operation, and maintenance of this product must be performed only by qualified personnel, in accordance with all applicable safety regulations and guidelines.

## 3.2. Consignes de Sécurité [Français]

Les informations qui suivent sont essentielles afin d'assurer la sécurité de l'utilisateur lors de l'installation et de l'opération de l'équipement. Assurez-vous de bien lire et de comprendre tous les avertissements et mises en garde qui suivent.

### 3.2.1. Conventions de Sécurité



#### NOTE:

Informations supplémentaires.



#### RISQUES DE CHOC ÉLECTRIQUE

Indique que l'action ou la partie de l'équipement concernée peut mener à des blessures par électrisation ou à la mort par électrocution si les précautions adéquates ne sont pas prises.



#### MISE EN GARDE

Indique la présence d'une situation dangereuse qui, si elle n'est pas évitée, pourrait mener à des blessures mineures à modérées ou à des dommages matériels.



#### AVERTISSEMENT

Indique la présence d'une situation dangereuse qui, si elle n'est pas évitée, pourrait mener à des blessures sévères ou à la mort.



#### MISE EN GARDE : PIÈCE ROTATIVE

Indique la présence de pièces d'équipement rotatives pouvant causer des blessures.



#### DANGER

Indique la présence d'une situation dangereuse qui, si elle n'est pas évitée, pourrait mener à des blessures sévères ou à la mort.

### 3.2.2. Consignes de Sécurité Générales



#### RISQUES DE CHOC ÉLECTRIQUE

L'utilisation des produits Cutsforth n'est recommandée qu'aux professionnels qualifiés qui savent comment reconnaître la présence de risques de choc électrique ainsi que les consignes de sécurité à suivre pour éviter les blessures liées à ces risques. Lesdites consignes de sécurité incluent, sans s'y limiter :

- Éviter tout contact avec des circuits alimentés;
- Éviter tout contact avec des pièces d'équipement rotatives;
- Ne jamais installer de composante ne paraissant pas fonctionner normalement;
- Toujours s'assurer que la structure de soutien et le câble de terre de l'arbre de la génératrice sont correctement installés.



#### RISQUES DE CHOC ÉLECTRIQUE

Avant de travailler sur la génératrice, désalimentez, cadenassez et étiquetez toutes les sources d'énergies liées à la génératrice, à l'arbre et aux appareils accessoires. L'opérateur s'expose à des risques de chocs électriques pouvant causer la mort s'il ne tient pas compte de cet avertissement.



#### MISE EN GARDE : PIÈCE ROTATIVE

Les pièces d'équipement rotatives et sous haute tension peuvent causer des blessures sévères ou fatales. L'installation, l'opération et la manutention de ce produit ne doivent être faites que par des professionnels qualifiés et en respectant toutes les règles et consignes de sécurité applicables.

## 4. Introduction

This manual is meant to act as a guide for the installation planning of the Electro-Magnetic Interference (EMI) Monitoring System.



This manual does not claim to cover all details or variations in equipment, nor does it consider every possible contingency for installation, operation, or maintenance. If you have questions or concerns that are not addressed in this installation planning guide, please contact Cutsforth Support.

## 5. Equipment List

To install the EMI Monitoring system, you need the equipment listed below. Some are provided by Cutsforth, and some are provided by the electrical contractor.

Equipment	Supplied by Cutsforth	Supplied by Electrical Contractor
High Frequency Current Transformer (CT) <ul style="list-style-type: none"> <li>EMMC-107 (46 mm)</li> <li>EMMC-108 (95 mm)</li> </ul>	✓	
Controller – one of the following: <ul style="list-style-type: none"> <li>cRIO-9055 4-slot controller</li> <li>cRIO-9042 4-slot controller</li> <li>cRIO-9058 8-slot controller</li> <li>cRIO-9047 8-slot controller</li> </ul>	✓	
NI-9770 RF monitor card	✓	
NEMA 4X rated enclosure	✓	
SMA connector - PE4008	✓	
BNC connector - PE4044	✓	
RG223 Flame Retardant Non-Corrosive (FRNC) cable - double shielded coax		✓
Conduit - 3/4 in metal for shielding effect for the CT cable should be considered		✓
Ethernet cable for connection to server		✓
600 volt rated power cable - 20 AWG minimum		✓

## 6. Planning the Electromagnetic Interference (EMI) Monitoring Installation

This section provides step-by-step guidance to plan the EMI Monitoring installation.

### 6.1. Planning the Layout

Identify a suitable installation location for the EMI Monitoring System. Location suitability should be based on the following factors:

- Proximity to similar monitoring equipment – do not install the EMI Monitoring System in a location where each of the HFCT circuits exceed 200 ft in wire length. Cables exceeding this length can negatively affect signal quality. Note that the HFCT cable lengths for each run do not need to be equidistant relative to each other.
  - Minimizing the distance is preferred to assure limited attenuation from the CT to the monitoring system. It is critical to understand that the monitoring system is measuring signals at the microvolt scale, and attenuation plays a significant role.
- The EMI Monitoring System has a minimum/maximum operating temperature range of –40 degrees C (–40 degrees F) to 70 degrees C (158 degrees F). Avoid mounting the enclosure in areas that approach or depart from this temperature range on a regular basis. If possible, avoid mounting the monitoring system in a location that experiences direct sunlight for extended periods of time throughout the day.
- Install the monitoring system in such a way that it does not complicate generator disassembly during outages.
- Ensure the monitoring system is accessible to personnel for servicing as needed. However, system surveillance and performance feedback is not viewable at the monitoring system panel.
- Ensure there is proximity to selected HFCT locations, 120VAC power source and data hub.

### 6.2. Planning the Current Transformer (CT) Locations

This section provides guidance for planning the location of the CT components.

#### 6.2.1. Option 1: Generator Neutral Ground Transformer (NGT)

If the installation has a stand-alone NGT cabinet and the lead coming into the NGT cabinet is in a conduit of a size that the EMMC-108 (95 mm) CT can fit around:

1. Open the EMMC-108.
2. Place the CT around the outside of the NGT lead conduit.
3. Latch the CT closed.

This preferred location gives the best EMI signal strength.

If the installation does not have a stand-alone NGT cabinet or the lead coming into the cabinet is too large for the EMMC-108 CT, then place the CT around the cable going into the high side of the neutral ground transformer. This option is not preferred because:

- It requires a plant outage to perform
- The neutral ground lead must be insulated to the full generator output voltage
- CT must be restrained from moving or touching the cable



If the CT comes into contact with the cable, it may cause damage to the cable insulation and cause the NGT to be bypassed in a phase to ground fault condition. This condition could cause very high currents to be generated during the fault condition and cause major equipment damage.

### 6.2.2. Option 2: Generator Step Up (GSU) Transformer

On the GSU transformer, the high-voltage side (grid side) usually has a WYE configuration with a neutral ground resistor to limit phase to ground fault currents. The center tap of the transformer WYE ties through this resistor to a ground connection. The connection to the tank ground and then grid ground is sometimes a bus bar connection and sometimes just a cable. For Auxiliary transformers (Unit Auxiliary, Reserve Auxiliary, Start-up, etc.), the high-voltage side is a delta configuration, and the low-voltage side (plant load) is a WYE connection to the ground through a neutral ground resistor to limit phase to ground fault currents.

The GSU HFCT shall be installed around the tank ground that is NOT connected to the high voltage WYE connection.

The GSU HFCT shall not be installed on the neutral side of the WYE connection or below the WYE connection for a few reasons:

- It is susceptible to high levels of grid noise that can make EMI analysis for the transformer defects difficult to detect and cause false position indications.
- It commonly has higher current flow which can potentially damage the signal acquisition equipment.
- It is not a preferred location unless you are also looking for switchyard anomalies, although switchyard anomalies are very difficult to quantify and very little has been attempted for switchyard phenomena using this technique.

The below image is an example of a bad HFCT installation location, as it is located below the WYE connection.



The below image is an example of a good HFCT installation location, as it is located above the WYE connection and is on the low voltage tank ground side.



### 6.2.3. Option 3: Potential Transformer Casing Ground

While monitoring of the Isolated Phase Bus (IPB) can be done with a CT monitoring generator, some clients may wish to have additional monitoring of the IPB area in an attempt to have better localization. Almost any ground attached to the outer PT enclosures can be used for this location. Multiple grounds ported to the earth through one ground lead can be used without much concern for external noise except the ground lead "antenna effect": the longer the ground lead the more external noise it may pick up.



## 6.2.4. Option 4: Generator Frame Ground

For locations where the NGT is inaccessible, you can use a generator frame ground for the CT location.

Portable monitoring with an interference analyzer should be performed during unit on line conditions to determine which frame ground location has the best signal strength.



The best signal is not always the one with the with the highest value but the one with the most internal noise values.

After the location has been determined, the installation will most likely utilize the EMMC-107 (46 mm) CT. Some installations only use the EMMC-108 CT for all monitoring purposes, but the EMMC-107 CT has similar response characteristics and is more cost effective.

For many Combustion Turbine Generators, the Exciter end frame ground is the lead of choice. Take care that the CT around the frame ground is coming directly from the frame casing and is not a combination of multiple ground leads. Having multiple ground leads introduces external noise and hampers the analysis process.



## 7. Installation

This section provides step-by-step instructions for installing the EMI Monitoring System enclosure.

1. Mount the EMI Monitoring System at the planned location.
2. Install the conduit between the EMI Monitoring System and each HFCT using separate conduit for each HFCT run.
3. Install the conduit for 120VAC power. Minimum circuit size: 20A 120VAC power supply free of non-linear loads. Consider a circuit with isolated ground.
4. Install the conduit and wire for data connection. Cutsforth recommends CAT6a or fiber connection.

### 7.1. Conduit Layout

This section provides conduit layout information for the standard painted or stainless steel enclosure styles and the optional legacy configuration enclosure.

#### 7.1.1. Conduit Layout for Painted or Stainless Steel Enclosure

Color on Diagram	Conduit Run Description	Conduit Trade Size*	Wire Description	Purpose	Max. Cable Length	Wire Supplied By
Green	Monitoring System to case ground	N/A	Single conductor, 12 AWG	Enclosure case ground	20 ft (6.1 m)	Cutsforth
Blue	Monitoring System to Control Room	3/4 in (2 cm)	Cat6a Cable	Data Output to Control Room	N/A	Plant Electrical Contractor
Purple**	HFCT to Monitoring System	3/4 in (2 cm)	RG-223 is preferred	CT Signal In	200 ft (61 m)	Plant Electrical Contractor
Red***	Plant Power to Monitoring Enclosure	3/4 in (2 cm)	120VAC Power (20A dedicated circuit – preferably with isolated ground)	Power for the Monitoring System	N/A	Plant Electrical Contractor

\*Enclosures do not come with conduit holes pre-drilled. Conduit sizing and hole placement is customizable. The cable glands and conduit fittings are intended to be installed by the plant electrical contractor. Please follow all local electrical standards applicable for gland and conduit installation. Additionally, ensure that the selected cable gland is equally or higher rated than the NEMA 4X rating of the equipment/enclosure in which they are installed.

\*\*Install each HFCT run in individual conduit runs and do not share conduits so as to avoid any cross talk between CT circuits.

\*\*\*A disconnecting switch or circuit breaker must be included in the installation. It must be suitably located, easily reached, and it must be marked as the disconnecting device for the equipment.

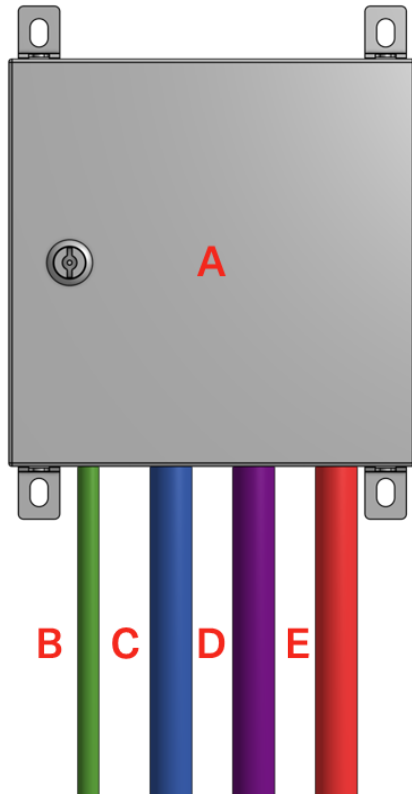

Part	Name
<b>A</b>	Cutsforth EMI Monitoring System
<b>B</b>	Green: 12 AWG wire for enclosure case ground
<b>C</b>	Blue: 3/4 in (2 cm) conduit for data output to control room
<b>D</b>	Purple: 3/4 in (2 cm) conduit from HFCT to monitoring system (one conduit run per HFCT)
<b>E</b>	Red: 3/4 in (2 cm) conduit for plant power

### 7.1.2. Conduit Layout for Optional Legacy Configuration



## 7.2. Conduit and Strut Channel Recommendations

Component	Standard Recommendation	Recommendation for High-Corrosion Environments
Conduit type	Galvanized rigid metal conduit (RMC)	Rigid Aluminum Conduit (RAC)
Conduit fittings type	Malleable, NEMA 4X rated or greater	Aluminum
Strut channel type	Hot dipped galvanized, back-to-back	316 Stainless steel
Mounting hardware	316 Stainless steel	316 Stainless steel
Liquid flexible metallic conduit	Type HCX	Type HCX

### 7.2.1. Recommended Strut Rack Design

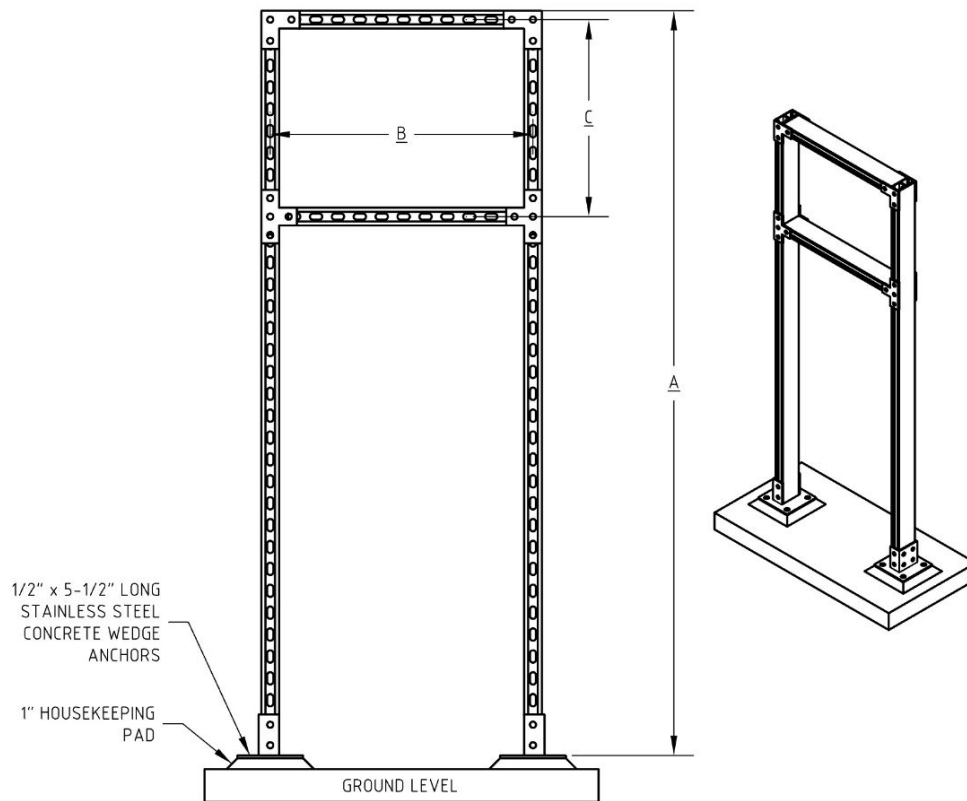

A in. (mm)	B in. (mm)	C in. (mm)
68 (1730)	24 (610)	Refer to enclosure mounting feet dimensions

## 8. Technical Specifications

This section provides the technical specifications for the EMI Monitoring installation.

### 8.1. Painted Steel Enclosure

Catalog Number	A	B	C	Steel Type	Door/Body Gauge	Latch Qty
SNB-3734	11.81 in (300 mm)	11.81 in (300 mm)	7.87 in (200 mm)	Painted Steel, Cold Rolled	16	1

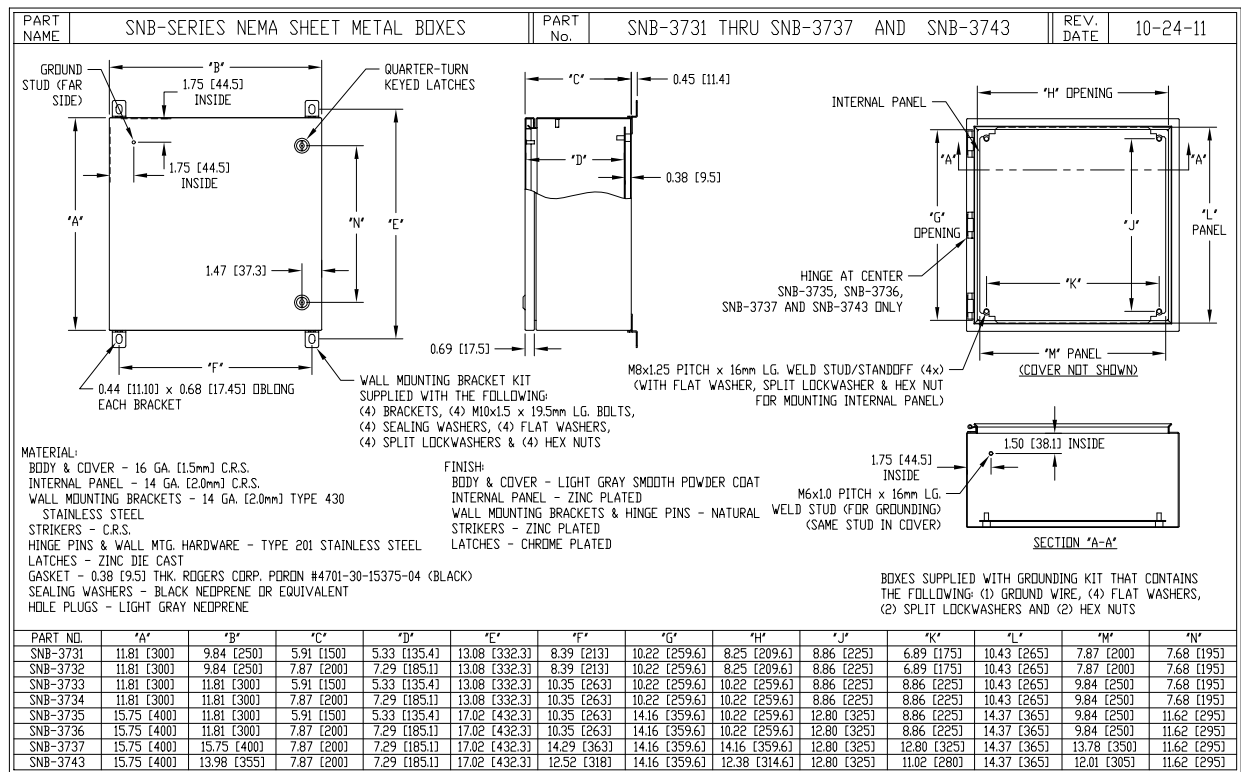

#### Specifications:

<ul style="list-style-type: none"> <li>UL 508A Listed: Type 1, 2, 4, 4X, 12, and 13</li> <li>UL File Number: E194432-20071011</li> <li>Meets NEMA 1, 2, 4, 4X, 12, 13 Requirements</li> <li>Meets IP66 Requirements</li> </ul>	<ul style="list-style-type: none"> <li>16 Gauge Cold Rolled Steel</li> <li>Light Gray Smooth Powder Coat</li> <li>Product Weight: 20 lb (9.1 kg)</li> </ul>
--	---

## 8.2. Stainless Steel Enclosure

Catalog Number	A	B	C	Steel Type	Door/Body Gauge	Latch Qty
EN4SD12126S16	12.0 in (305 mm)	12.0 in (305 mm)	6.00 in (152 mm)	316 Stainless	16	1

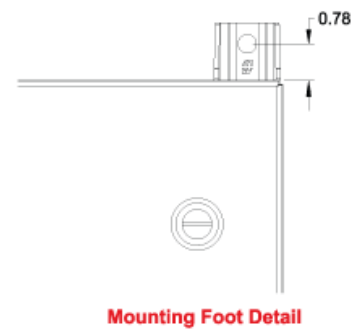
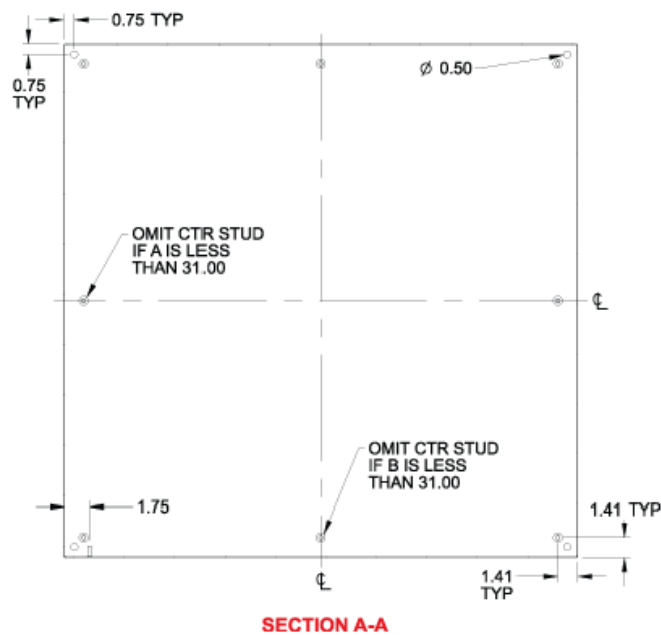
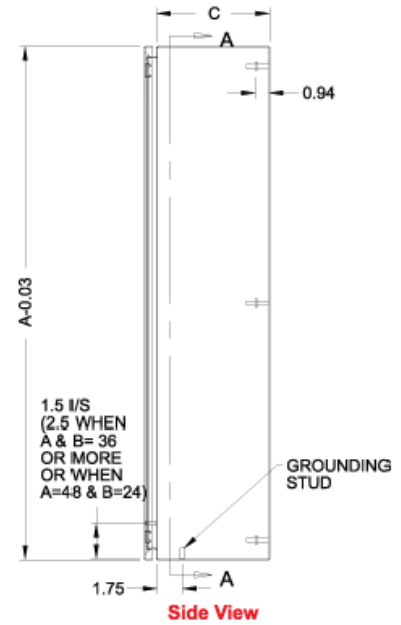
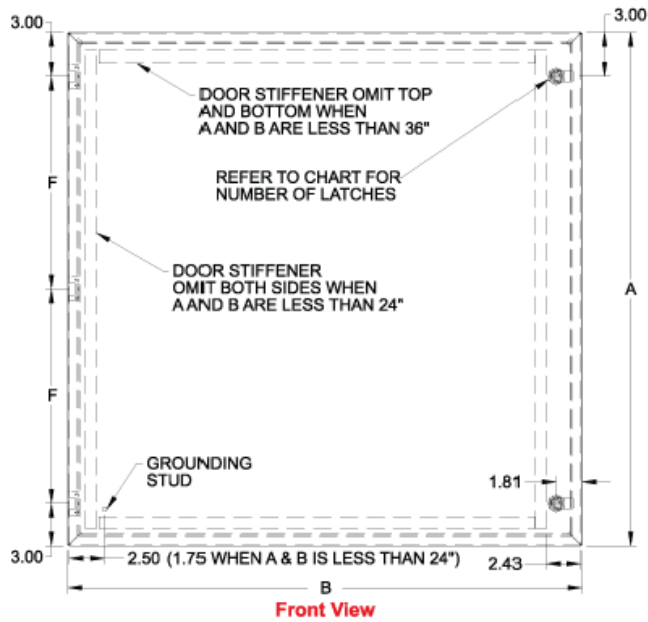

**Specifications:**

<ul style="list-style-type: none"><li>▪ UL 508A Type 3R, 4, 4X, 12</li><li>▪ UL File: E65234</li><li>▪ CSA Type 3R, 4, 4X, 12</li><li>▪ CSA Cert: LR21001</li></ul>	<ul style="list-style-type: none"><li>▪ Meets NEMA 3R, 4, 4X, 12, 13 Requirements</li><li>▪ Meets IP 66 Requirements</li><li>▪ 16 Gauge Stainless Steel</li><li>▪ Product Weight: 20 lb (9.1 kg)</li></ul>
---	--

## 8.3. Optional Legacy Configuration

### 8.3.1. Main Enclosure

Catalog Number	Dimensions (in. (mm))
CSD16168SS6-MODS	16.0 (406) x 16.0 (406) x 8.0 (203)

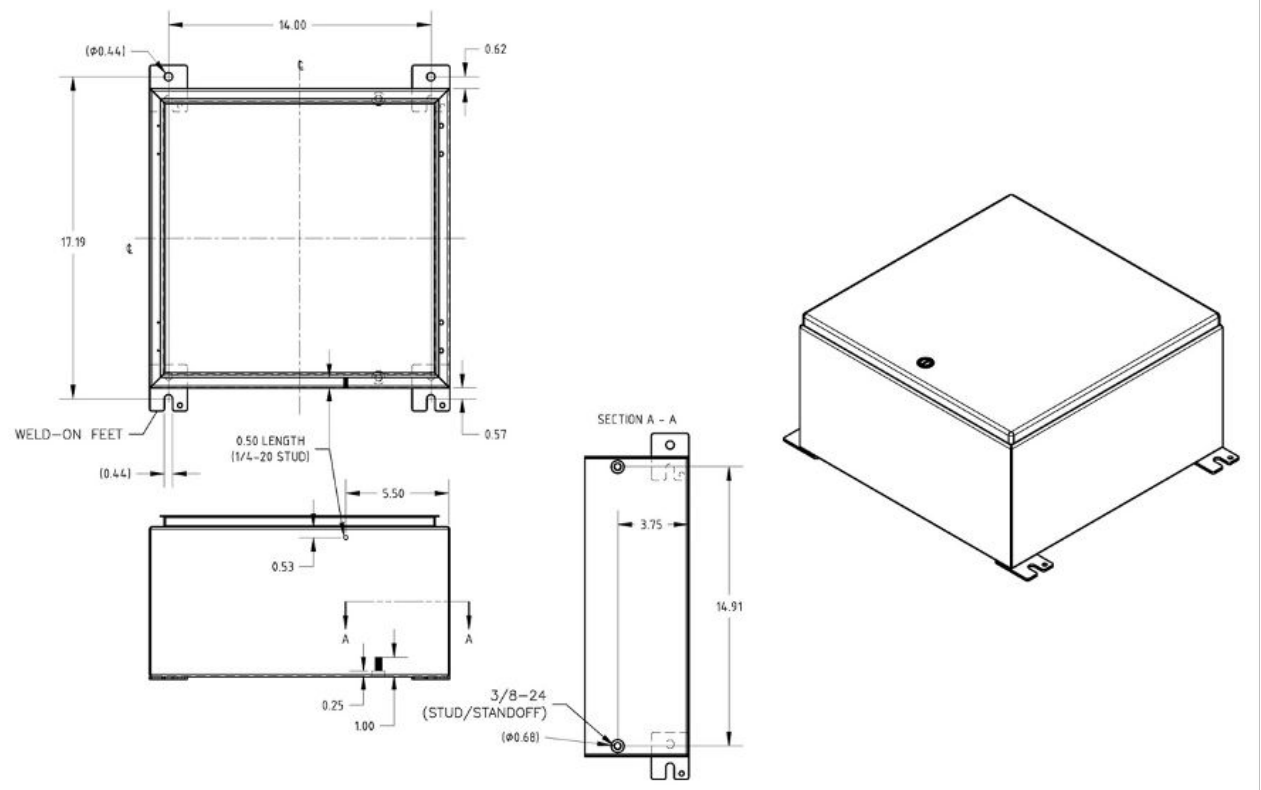

#### Specifications:

- |   |  |
|---|--|
| <ul style="list-style-type: none"> <li>▪ UL 508A Listed; Type 3R, 4, 4X, 12; File No. E61997</li> <li>▪ cUL Listed per CSA C22.2 No 94; Type 3R, 4, 4X, 12; File No. E61997</li> <li>▪ NEMA/EEMAC Type 3R, 4, 4X, 12, 13</li> <li>▪ CSA File No. 42186; Type 4, 4X, 12</li> </ul> | <ul style="list-style-type: none"> <li>▪ VDE IP66</li> <li>▪ IEC 60529, IP66</li> <li>▪ Meets NEMA Type 3RX requirements</li> <li>▪ Stainless Steel Type: 316</li> </ul> |
|---|--|

EXMC-002: Optional sunshield for outdoor installations

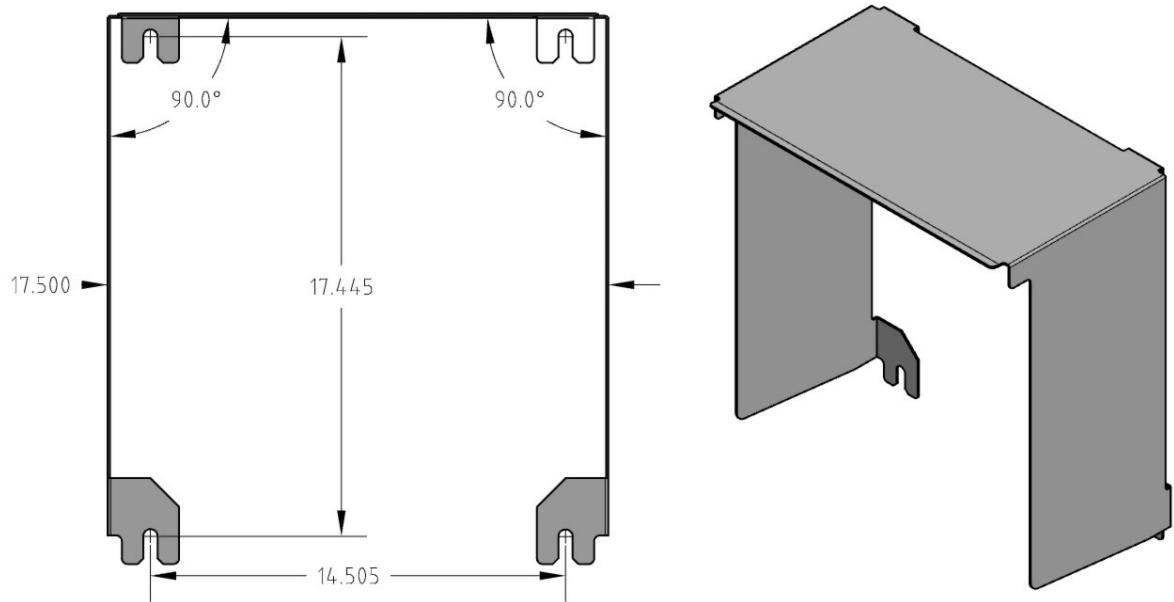

**8.3.2. Power Supply Enclosure**

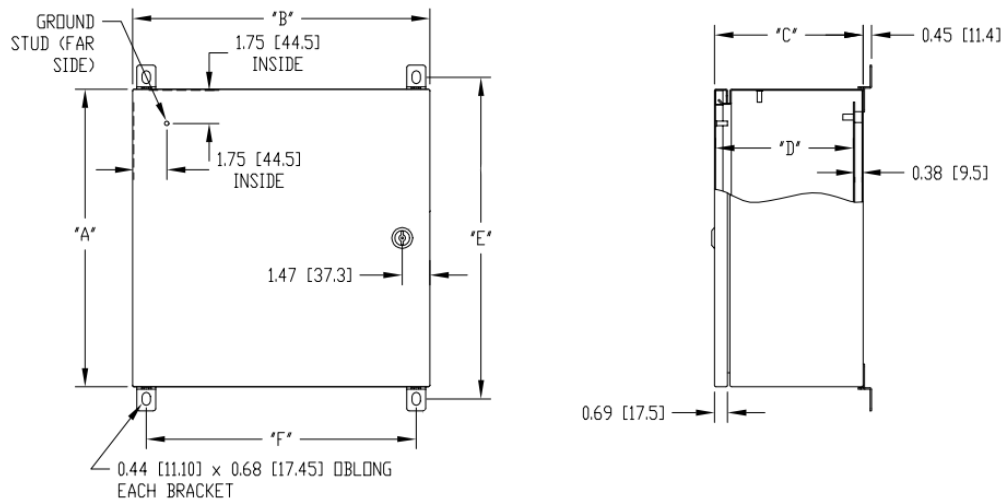

Catalog Number	A in (mm)	B in (mm)	C in (mm)	D in (mm)	E in (mm)	F in (mm)
SNB-3740-SS	9.84 (250)	9.84 (250)	5.91 (150)	5.33 (135)	11.12 (282)	8.39 (213)

**Specifications:**

<ul style="list-style-type: none"> <li>▪ UL 508A Listed: Type 4X</li> <li>▪ File No. E194432</li> <li>▪ Meets UL50E requirements</li> <li>▪ NEMA Rating: 1, 2, 4, 4X, 12, and 13</li> </ul>	<ul style="list-style-type: none"> <li>▪ IP Rating: IP65 and IP66</li> <li>▪ Stainless Steel Type: 304</li> <li>▪ RoHS</li> </ul>
---	---

## 8.4. Approved Manufacturing Locations

Cutsforth, Inc.

5160 Industrial Place #101

Ferndale, WA 98248

## 8.5. Product Certifications

**Table 1. EU Directive Information – CE Compliance**

Electro Magnetic Compatibility (EMC) Directive 2014/30/EU	EN 61326-1:2013
Low Voltage Directive (LVD) 2014/35/EU	IEC 61010-1: 2010; EN 61010-1-2010
RoHS Directive 2011/65/EU	Large Scale Fixed Installation Exclusion

**Table 2. North America**

Electro Magnetic Compatibility (EMC)	Conforms to FCC 47CFR 15: 2022, Certified to CSA Std. ICES-001 2020
Safety	Conforms to UL 61010-1: 2012 Ed.3+R: 19-Jul-2019, Certified to CSA C22.2 61010-1: 2012 Ed. 3+U1;U2; A1

**Table 3. UK Conformity Assessed (UKCA)**

Electro Magnetic Compatibility (EMC) 2016	EN 61326-1:2013
Electrical Equipment (Safety) Regulations 2016	EN 61010-1-2010
Regulations: Restriction of Hazardous Substances (RoHS)	Large Scale Fixed Installation Exclusion

### WEEE Directive Statement

In accordance with Article 14 of Directive 2012/19/EU on Waste Electrical and Electronic Equipment (WEEE), the following marking requirements apply:

- The directive applies to electrical and electronic equipment falling under Annex I, Category 9 of Directive 2012/19/EU.
- Products must include markings that clearly identify the producer and indicate that the equipment was placed on the market after 13 August 2005.

- The crossed-out wheeled bin symbol signifies that the equipment must not be disposed of with unsorted municipal waste. End users are required to follow applicable local recycling and disposal procedures for electrical and electronic equipment.
- The marking affixed to the product confirms that it falls within the scope of this directive.

## 8.6. Environmental Requirements

Storage Temperature	-40°C to 85°C (-40°F to 185°F)
Operating Temperature	-20°C to 60°C (-4°F to 140°F)
Storage Humidity	5% RH to 95% RH, non-condensing
Operating Humidity	10% RH to 90% RH, non-condensing
Maximum Altitude	2,000 m (6,560 ft)
Installation Location	For either indoor or outdoor installations
Overvoltage Category	II
Pollution Degree	2

## 8.7. AC Power Supply Requirements

Plant-supplied power source	120 V, 60 Hz AC or 240 V, 50 Hz
Circuit breaker	Internal 120 V, 5 A
Current draw under normal usage	Approximately 0.6 A

## 8.8. AC Power Specifications

Input Voltage Range	85 - 264 VAC
Input Frequency Range	47 - 63 Hz
Input Power Rating	150 W
Over Voltage Category	III ; According to EN62368, EN61558, EN50178, EN60664-1, EN62477-1
Input Wire Connection Type	DIN, Screw-Down Terminal Block
Input Wire Size	26 - 10 AWG

## 8.9. DC Power Input Specifications

Input Voltage	Input Power
24 VDC	24 W

## 8.10. Electromagnetic Compatibility

This product meets the requirements of the following EMC standards for electrical equipment for measurement, control, and laboratory use:

EN 61326 (IEC 61326)	Class A emissions; Basic immunity
EN 55011 (CISPR 11)	Group 1, Class A emissions
AS/NZS CISPR 11	Group 1, Class A emissions
FCC 47 CFR Part 15B	Class A emissions
ICES-001	Class A emissions
CE Compliance	Meets the essential requirements of applicable European Directives, as amended for CE marking, as follows: 2006/95/EC, Low-Voltage Directive (safety); 2004/108/EC, Electromagnetic Compatibility Directive (EMC)

## 9. Integration and Infrastructure

The Cutsforth EMI Monitoring System is designed to be integrated into InsightCM™ software. For more information on InsightCM™, including specific server requirements, visit the InsightCM™ README on the Cutsforth Support webpage at <https://support.cutsforth.com>.

The plant must provide a PC or Server for InsightCM™ meeting the requirements listed at the above link. Cutsforth is not responsible for the configuration of server-side deployment. Ensure the plant's InsightCM™ server is set up and ready for communication to field equipment in advance of system commissioning by Cutsforth.

## 10. Responsibilities

The following tables summarize the responsibilities of Cutsforth and the Plant during the four project phases:

### 10.1. Planning Phase

Task	Cutsforth	Plant
Review this planning guide document and share it with key plant personnel involved in the project.		✓
Determine enclosure mounting positions and conduit routes customized to the generator and ensure that they are within system guidelines.		✓
Select an Electrical Contractor and Coordinate.		✓

### 10.2. Preparation for Service Phase

Task	Cutsforth	Plant
Determine the HFCT installation location(s) with help from Cutsforth, using the <a href="#">Planning the Current Transformer (CT) Locations (page 12)</a> section of this document for guidance.	✓	✓
Determine the monitoring system enclosure mounting location and conduit routing and ensure it is within system requirements.		✓
Mount the monitoring system enclosure with supporting strut channel rails and install required conduit.		✓

### 10.3. Cutsforth Service Phase – Cutsforth Technicians On-site

Task	Cutsforth	Plant
Ensure the generator is in the needed condition for the scope of work.		✓
LOTO requirements: Depends upon installation approach. It is possible to perform this installation with the generator in service.		✓
Provide 120V power (GFI-protected is preferred) for installation tooling.		✓
Provide adequate working access to the installation site including scaffolding if required for worker access.		✓
Perform system testing and commissioning.	✓	
Provide control room support for testing signal outputs.	✓	✓

## 10.4. InsightCM Phase

Task	Cutsforth	Plant
Review <a href="#">InsightCM™ Server Requirements</a> .		✓
Procure a server for InsightCM™ (if not done already).		✓
Verify that server meets requirements before installing software.		✓
Verify server prerequisites are checked (IIS Role).		✓
Install InsightCM™ on the server.		✓
Install the <a href="#">Google Chrome</a> browser on the server.		✓
If using a Windows 10 server, inquire with Cutsforth about the NI RAD Utility. Otherwise, skip this step.		✓
Power on the Cutsforth monitoring equipment.	✓	
Configure IP addresses for the Cutsforth monitoring equipment from the server.		✓
Connect the Cutsforth device to the server using an Ethernet or fiber cable.		✓
Create the device's asset tree in InsightCM™ and validate.		✓
Create the device in InsightCM™ using the configured IP addresses.		✓
Configure desired alarm settings, if desired alarms are known.		✓
Using InsightCM™, establish a connection to the field device.		✓
Confirm data is being collected, can be viewed in InsightCM™, and is accurate. This task would likely be performed by Cutsforth's Software and Electronics team after the service portion of the installation has been completed.	✓	✓

Cutsforth offers all of the tasks listed in the InsightCM™ Phase as a service. Please inquire if you are interested in having Cutsforth perform these tasks.

## 11. Glossary

AWG	American Wire Gauge
Current Transformer (CT)	A device used to measure alternating current (AC).
Electromagnetic Interference (EMI) analysis	The capture and analysis of both controlled and uncontrolled electromagnetic emissions absorbed by electrical utility equipment (generators, motors, transformers, switchgears, etc.) to determine if any uncontrolled sources of discharge are being emitted from within the electrical utility equipment.
Generator Step-Up Transformer (GSU)	A transformer that takes the voltage from the generator and brings it up to the proper transmission voltage.
High Frequency Current Transformer (HFCT)	A device used to measure alternating current (AC) with high frequency.
Isolated Phase Bus (IPB)	A set of high current carrying conductors used to connect the generator to the step-up transformer.
Neutral Ground Transformer (NGT)	A device used to provide a path to ground in an effort to bring the system ground and system neutral to equal potentials.
Partial Discharge (PD)	According to IEC 60270 standard: <i>Partial discharge (PD) is a localized electrical discharge that only partially bridges the insulation between conductors and which may or may not occur adjacent to a conductor.</i>
power supply enclosure	A Cutsforth enclosure that houses a power supply which accepts AC power from the plant and converts it to DC for use in various Cutsforth monitoring systems.
Resistance Temperature Detector (RTD)	A device that measures temperature by detecting the changes in resistance of an internal thermometer element.