

Operations Manual EZDP-2058 Rev N Brush Condition Monitoring



Table of Contents

1. About Cutsforth	4
1.1. Cutsforth Products	4
1.2. Cutsforth Field Services	4
1.3. Cutsforth Automation and Control Services	4
2. Legal Information	5
2.1. Limited Warranty	5
2.2. Copyright	6
2.3. Patents	6
2.4. Federal Communications Commission Requirements	6
2.4.1. Brush Condition Monitoring - Primary Controller	6
2.4.2. Brush Health Sensor	6
2.5. ISED Canada Regulatory Compliance Statement	7
3. Safety Information	8
3.1. Safety Information [English]	8
3.1.1. Safety Conventions	8
3.1.2. General Safety Instructions	8
3.2. Consignes de Sécurité [Français]	9
3.2.1. Conventions de Sécurité	9
3.2.2. Consignes de Sécurité Générales	10
4. EASYchange® Brush Condition Monitoring	11
5. Brush Condition Monitoring (BCM) Technical Specifications	13
5.1. Primary Controller Technical Specifications	13
5.2. BHS Technical Specifications	13
5.3. Data from Primary Controller	14
6. Primary Controller Overview	15
7. Brush Condition Monitoring System Installation	16
7.1. Mounting the Brush Condition Monitoring System Enclosure	17
7.1.1. Brush Condition Monitoring System Mounting Requirements	17
7.2. Running Power to the Brush Conditioning Monitoring System	18
7.3. Route the Antenna Cabling	19
7.4. Install Brush Holder Label Clips	20
8. Brush Health Sensors	21
8.1. Pair a New Sensor	21
8.2. Frequency of Sensor Updates	22
8.3. Unpair a Sensor	22
8.3.1. Replacing a Brush	22
8.4. Brush Health Sensor Battery Life	23
8.5. Button-On Self Test	24
9. Using the Primary Controller System User Interface	25
9.1. Power On the Primary Controller	25
9.2. Primary Controller System Screen Layout	25
9.3. Navigating the Primary Controller Screen	28
9.4. Power Off the Primary Controller	29
10. Connecting an Auxiliary Display	30
11. Brush Status Indication	31
11.1. Color Definitions	32
12. Configure the Brush Condition Monitoring System Settings	33

13. Advanced Configuration Settings	35
13.1. Access the Advanced Configuration Window	36
13.2. Export Data and Event Logs	37
13.3. Update the Brush Condition Monitoring Application	38
13.4. Update the Brush Health Sensor Firmware	39
13.5. Set the Brush Condition Monitoring System Time	40
14. Generator Settings	43
14.1. Measurement Interval	44
15. Antenna Placement Mode	45
16. Modbus Interface	47
16.1. Entering a Static IP Address	50
16.2. Locating the MAC Addresses	54
16.3. Modbus RTU Configuration	56
17. Frequently Asked Questions (FAQ)	58
18. Glossary	60

1. About Cutsforth

Cutsforth specializes in developing innovative new technologies and services to support the power generation industry. Cutsforth's patented EASYchange® brush holder design, online truing service, InsightCM™ condition monitoring software, and patented shaft grounding and monitoring systems have been installed across the globe in generators of all sizes and in nearly every industry application, including nuclear, natural gas, coal, wind, and hydroelectric.

Cutsforth's knowledge and commitment to excellence drives our innovative solutions for the changing needs of the power industry. Whether it is a quick response to a critical situation or a new way of solving an old problem, our commitment to quality ensures that our customers receive best-in-class products and services—Cutsforth is the Power of Innovation.

Cutsforth started back in 1991 as a small company focused primarily on making replacement brush holders for generators and exciters. Today, after 30+ years in business, Cutsforth's experience and innovative designs have brought its best-in-class excitation brush holder and shaft grounding replacements and collector ring services to some of the world's largest power companies.

1.1. Cutsforth Products

- [EASYchange® Removable Brush Holders](#)
- [EASYchange® Brush Condition Monitoring](#)
- [Cutsforth Shaft Grounding Systems](#)
- [Rotor Flux Monitoring](#)
- [Electro-Magnetic Interference Monitoring](#)
- [InsightCM™ Condition Monitoring Software](#)

1.2. Cutsforth Field Services

Cutsforth provides comprehensive product installations for all product offerings as well as on-site training after the installation. We work efficiently during your outage to ensure a smooth upgrade to our innovative solutions such as Product Installations, Online Collector Ring and Commutator Truing, Spiral Groove Restoration, and Consulting and Emergency Services.

1.3. Cutsforth Automation and Control Services

Cutsforth provides comprehensive Automation and Control services which include data historian integration, InsightCM™ integration, DCS logic, engineered drawings and much more. This further complements our turnkey monitoring system installations.

2. Legal Information

2.1. Limited Warranty

This document is provided 'as is' and is subject to being changed, without notice, in future editions. Cutsforth reviews this document carefully for technical accuracy; however, CUTSFORTH MAKES NO EXPRESS OR IMPLIED WARRANTY AS TO THE ACCURACY OF THE INFORMATION WITHIN THIS MANUAL AS IT RELATES TO SPECIFIC INSTALLATION. THE CUSTOMER IS RESPONSIBLE FOR VERIFYING INSTALLATION AND OPERATING CONDITIONS AT EACH INSTALLATION LOCATION AND FOR EACH GENERATOR TYPE. Cutsforth warrants that its hardware products will be free of defects in materials and workmanship that cause the product to fail to substantially conform to the applicable Cutsforth published specifications for one (1) year from the date of invoice.

For a period of ninety (90) days from the date of invoice, Cutsforth warrants that (i) its software products will perform substantially in accordance with the applicable documentation provided with the software, and (ii) the software media will be free from defects in materials and workmanship. If Cutsforth receives notice of a defect or non-conformance during the applicable warranty period, Cutsforth will, in its discretion: (i) repair or replace the affected product, or (ii) refund the fees paid for the affected product. Repaired or replaced hardware will be warranted for the remainder of the original warranty period or ninety (90) days, whichever is longer. If Cutsforth elects to repair or replace the product, Cutsforth may use new or refurbished parts or products that are equivalent to new in performance and reliability and are at least functionally equivalent to the original part or product. You must obtain an RMA number from Cutsforth before returning any product to Cutsforth. Cutsforth reserves the right to charge a fee for examining and testing hardware not covered by the Limited Warranty.

This Limited Warranty does not apply if the defect of the product resulted from improper or inadequate maintenance, installation, repair, or calibration performed by a party other than Cutsforth; unauthorized modification; improper environment; use of an improper hardware or software key; improper use or operation outside of the specification for the product; improper voltages; accident, abuse, or neglect; or a hazard such as lightning, flood, or other act of nature.

THE REMEDIES SET FORTH ABOVE ARE EXCLUSIVE AND THE CUSTOMER'S SOLE REMEDIES, AND SHALL APPLY EVEN IF SUCH REMEDIES FAIL OF THEIR ESSENTIAL PURPOSE.

WARNING REGARDING USE OF CUTSFORTH SHAFT MONITORING EQUIPMENT: CUSTOMER IS ULTIMATELY RESPONSIBLE FOR VERIFYING AND VALIDATING THE SUITABILITY AND RELIABILITY OF THE PRODUCTS WHENEVER THE PRODUCTS ARE INCORPORATED IN THEIR SYSTEM OR APPLICATION, INCLUDING THE APPROPRIATE DESIGN, PROCESS, AND SAFETY LEVEL OF SUCH SYSTEM OR APPLICATION. PRODUCTS ARE NOT DESIGNED, MANUFACTURED, OR TESTED FOR USE IN LIFE OR SAFETY CRITICAL SYSTEMS, OR ANY OTHER APPLICATION IN WHICH THE FAILURE OF THE PRODUCT OR SERVICE COULD LEAD TO DEATH, PERSONAL INJURY, SEVERE PROPERTY DAMAGE OR ENVIRONMENTAL HARM (COLLECTIVELY, "HIGH-RISK USES"). FURTHER, PRUDENT STEPS MUST BE TAKEN TO PROTECT AGAINST FAILURES, INCLUDING PROVIDING BACK-UP AND SHUT-DOWN MECHANISMS. CUTSFORTH EXPRESSLY DISCLAIMS ANY EXPRESS OR IMPLIED WARRANTY OF FITNESS OF THE PRODUCTS OR SERVICES FOR HIGH-RISK USES.

CUTSFORTH DOES NOT WARRANT, GUARANTEE, OR MAKE ANY REPRESENTATIONS REGARDING THE USE OF OR THE RESULTS OF THE USE OF THE PRODUCTS IN TERMS OF CORRECTNESS, ACCURACY, RELIABILITY, OR OTHERWISE. CUTSFORTH DOES NOT WARRANT THAT THE OPERATION OF THE PRODUCTS WILL BE UNINTERRUPTED OR ERROR FREE. INCIDENTAL AND CONSEQUENTIAL DAMAGES, INCLUDING LOSS OF USE, ARE SPECIFICALLY EXCLUDED FROM THIS WARRANTY; THE MAXIMUM VALUE OF A WARRANTY CLAIM CANNOT EXCEED THE ORIGINAL VALUE OF THE ASSEMBLY OR COMPONENT.

2.2. Copyright

Under copyright law, this publication may not be reproduced or transmitted in any form, electronic or mechanical, including photocopying, recording, storing in an information retrieval system, or translating, in whole or in part, without the prior written consent of Cutsforth. Cutsforth respects the intellectual property of others, and we ask our users to do the same. Cutsforth software is protected by copyright and other intellectual property laws. Cutsforth software is only licensed to be run on the intended hardware for which it was purchased. Reproduction of software or written materials is prohibited unless Customer has obtained a license for that express purpose.

2.3. Patents

Please send patent information requests to patents@cutsforth.com.

2.4. Federal Communications Commission Requirements

2.4.1. Brush Condition Monitoring - Primary Controller

Primary Controller: Utilizes Intel RF module 8265NG

FCC ID: PD98265NG

IC ID: 1000M-8265NG

2.4.2. Brush Health Sensor

Part #: EBHS001

FCC ID: 2ARPJ-EBHS001

IC ID: 24545-EBHS001

This device complies with part 15 of the FCC Rules. Operation is subject to the following two conditions:

(1) This device may not cause harmful interference, and

(2) this device must accept any interference received, including interference that may cause undesired operation.



Caution: User changes or modifications not expressly approved by the party responsible for compliance could void the user's authority to operate the equipment.



Note: This equipment has been tested and found to comply with the limits for a Class A digital device, pursuant to part 15 of the FCC Rules. These limits are designed to provide reasonable protection against harmful interference when the equipment is operated in a commercial environment. This equipment generates, uses, and can radiate radio frequency energy and, if not installed and used in accordance with the instruction manual, may cause harmful interference to radio communications. Operation of this equipment in a residential area is likely to cause harmful interference in which case the user will be required to correct the interference at his own expense.

2.5. ISED Canada Regulatory Compliance Statement

This device contains licence-exempt transmitter(s)/receiver(s) that comply with Innovation, Science and Economic Development Canada licence-exempt RSS(s). Operation is subject to the following two conditions:

1. This device may not cause interference.
2. This device must accept any interference, including interference that may cause undesired operation of the device.

L'émetteur/récepteur exempt de licence contenu dans le présent appareil est conforme aux CNR d'Innovation, Sciences et Développement économique Canada applicables aux appareils radio exempts de licence. L'exploitation est autorisée aux deux conditions suivantes :

1. L'appareil ne doit pas produire de brouillage;
2. L'appareil doit accepter tout brouillage radioélectrique subi, même si le brouillage est susceptible d'en compromettre le fonctionnement.

3. Safety Information

3.1. Safety Information [English]

Following is important safety information. For safe installation and operation of this equipment, be sure to read and understand all cautions and warnings.

3.1.1. Safety Conventions



NOTE:

Additional information.



ELECTRICAL DANGER

Indicates an action or specific equipment area that can result in personal injury or death from an electrical hazard if proper precautions are not taken.



CAUTION

Indicates a hazardous situation that, if not avoided, could result in minor or moderate injury or equipment damage.



WARNING

Indicates a hazardous situation that, if not avoided, could result in death or serious injury.



ROTATING PART CAUTION

Indicates possible injury from rotating parts.



DANGER

Indicates a hazardous situation that, if not avoided, will result in death or serious injury.

3.1.2. General Safety Instructions



ELECTRICAL DANGER

Only qualified personnel who recognize shock hazards and are familiar with the safety precautions required to avoid injury should work with Cutsforth products. Among the many considerations are the following:

- Avoid contact with energized circuits.
- Avoid contact with rotating parts.
- Never install any component that appears not to be functioning in a normal manner.
- Always ensure proper installation of the holder assembly and shaft grounding rope.



ELECTRICAL DANGER

Before working on the generator, de-energize, lock out, and tag out all power sources to the generator, shaft, and accessory devices. Electric shock and death may result due to failure to heed this warning.



ROTATING PART CAUTION

High-voltage and rotating parts can cause serious or fatal injury. Installation, operation, and maintenance of this product must be performed only by qualified personnel, in accordance with all applicable safety regulations and guidelines.



WARNING

Never mix different carbon brush grades or brushes from different manufacturers on the same unit.

3.2. Consignes de Sécurité [Français]

Les informations qui suivent sont essentielles afin d'assurer la sécurité de l'utilisateur lors de l'installation et de l'opération de l'équipement. Assurez-vous de bien lire et de comprendre tous les avertissements et mises en garde qui suivent.

3.2.1. Conventions de Sécurité



NOTE:

Informations supplémentaires.



RISQUES DE CHOC ÉLECTRIQUE

Indique que l'action ou la partie de l'équipement concernée peut mener à des blessures par électrisation ou à la mort par électrocution si les précautions adéquates ne sont pas prises.



MISE EN GARDE

Indique la présence d'une situation dangereuse qui, si elle n'est pas évitée, pourrait mener à des blessures mineures à modérées ou à des dommages matériels.



AVERTISSEMENT

Indique la présence d'une situation dangereuse qui, si elle n'est pas évitée, pourrait mener à des blessures sévères ou à la mort.



MISE EN GARDE : PIÈCE ROTATIVE

Indique la présence de pièces d'équipement rotatives pouvant causer des blessures.



DANGER

Indique la présence d'une situation dangereuse qui, si elle n'est pas évitée, pourrait mener à des blessures sévères ou à la mort.

3.2.2. Consignes de Sécurité Générales



RISQUES DE CHOC ÉLECTRIQUE

L'utilisation des produits Cutsforth n'est recommandée qu'aux professionnels qualifiés qui savent comment reconnaître la présence de risques de choc électrique ainsi que les consignes de sécurité à suivre pour éviter les blessures liées à ces risques. Lesdites consignes de sécurité incluent, sans s'y limiter :

- Éviter tout contact avec des circuits alimentés;
- Éviter tout contact avec des pièces d'équipement rotatives;
- Ne jamais installer de composante ne paraissant pas fonctionner normalement;
- Toujours s'assurer que la structure de soutien et le câble de terre de l'arbre de la génératrice sont correctement installés.



RISQUES DE CHOC ÉLECTRIQUE

Avant de travailler sur la génératrice, désalimentez, cadenassez et étiquetez toutes les sources d'énergies liées à la génératrice, à l'arbre et aux appareils accessoires. L'opérateur s'expose à des risques de chocs électriques pouvant causer la mort s'il ne tient pas compte de cet avertissement.



MISE EN GARDE : PIÈCE ROTATIVE

Les pièces d'équipement rotatives et sous haute tension peuvent causer des blessures sévères ou fatales. L'installation, l'opération et la manutention de ce produit ne doivent être faites que par des professionnels qualifiés et en respectant toutes les règles et consignes de sécurité applicables.



AVERTISSEMENT

Ne jamais utiliser de frotteurs de différentes qualités ou venant de différents fabricants sur le même appareil.

4. EASYchange® Brush Condition Monitoring

For over 30 years, Cutsforth has installed over 35,000 of the best-in-class brush holders on turbine generators worldwide. Now, with our exclusive EASYchange® Brush Condition Monitoring, Cutsforth offers an even better way to operate your generator's brush-type excitation. Brush performance metrics can now be delivered to the control room system and maintenance can be performed based on brush condition, rather than a calendar.

Automated measurements and brush health analytics allow plant operators to improve the efficiency of technicians' daily and weekly tasks by dispatching them to the collector when maintenance is actually needed.

The Brush Condition Monitoring System is composed of:

- a Cutsforth-developed industrial data logger product known as the Brush Health Sensor (BHS) (A) shown installed on the EASYchange® brush holder, and
- a Sensor Controller touch-screen interface (B) that compiles the data collected from several BHS units installed with the EASYchange® brush holders.

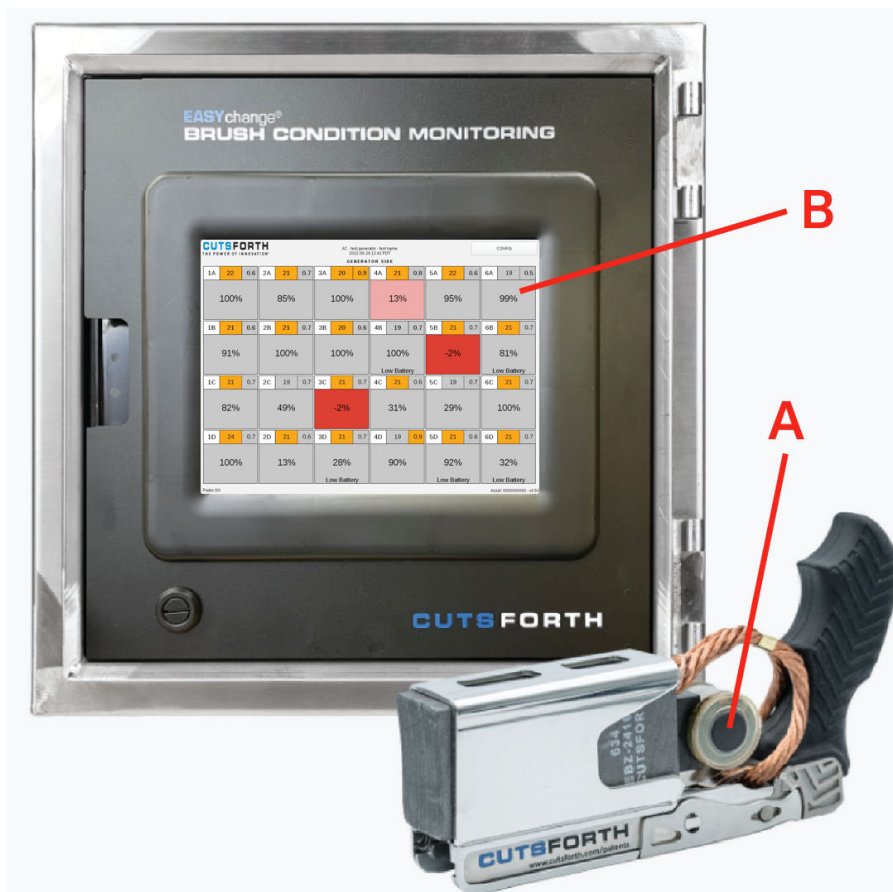

Cutsforth's patented hardware and technology processes and transmits the following data points over a 2.4 GHz wireless link to local displays as well as via Modbus protocol into a plant's DCS, Historian, or InsightCM™.

5. Brush Condition Monitoring (BCM) Technical Specifications

5.1. Primary Controller Technical Specifications

- USB 3.0
- Touchscreen interface
- Optional secondary display
- 2.4 GHz RF Bluetooth Low Energy (BLE) interface
- Operating Temperature -20 to 70 °C (-4 to 158 °F)
- Communication to plant control room has three interface options:
 - Modbus TCP over Ethernet
 - Modbus RTU over RS-232
 - InsightCM™ over Ethernet
- AC Main Power in:
 - Input voltage: 85–264 VAC, 47–63Hz
 - Input power: 150W Max
- Enclosure is NEMA 4X rated when closed

5.2. BHS Technical Specifications

- Operating Temperature: 0 to 105 °C (32 to 221 °F)
- Battery powered from lithium metal primary cells
- LED lights on sensors to provide visual feedback for operators
- Push button activation on each sensor
- 2.4 GHz RF Bluetooth Low Energy (BLE) transceiver
- IP6X dustproof

5.3. Data from Primary Controller

Most Recent Recorded Values (Local)	Configurable Brush Health Alerts (Local)	Historical Data Trending (Output to Historian)
<ul style="list-style-type: none"> ▪ Usable Brush Length (%) ▪ Brush Vibration (Mils Displacement, Pk-to-Pk) ▪ Temperature 	<ul style="list-style-type: none"> ▪ Brush Length Warnings ▪ High Vibration ▪ Temperature 	<ul style="list-style-type: none"> ▪ Usable Brush Length ▪ Vibration ▪ Ambient Temperature at Brush Health Sensor (BHS) ▪ BHS Battery Life ▪ System Status ▪ System Date/Time ▪ Temperature <p>See Modbus Interface (page 47) for a complete list.</p>

6. Primary Controller Overview

The Primary Controller receives data from the Brush Health Sensors (BHS) at regular intervals. It presents information based on the received data to users locally using up to two industrial displays, and to remote users over Modbus TCP, Modbus RTU, or over Ethernet into InsightCM™ software.

At the generator, the Primary Controller user interface visually alerts users of short brushes and high vibrations based on plant-defined thresholds. This same critical data and more can also be relayed to the control room, reducing unnecessary physical inspections. Some installation may make use of an Auxiliary Display, which is a fully-functioning duplication of the primary display that can be placed at a secondary location near the brush rigging if desired.

Brush health historical analytics are logged by the system and available on the Brush Detail screen for each brush holder location. Ultimately, the combination of recent and historical brush health analytics will improve operator efficiencies and optimize a plant's staff utilization.

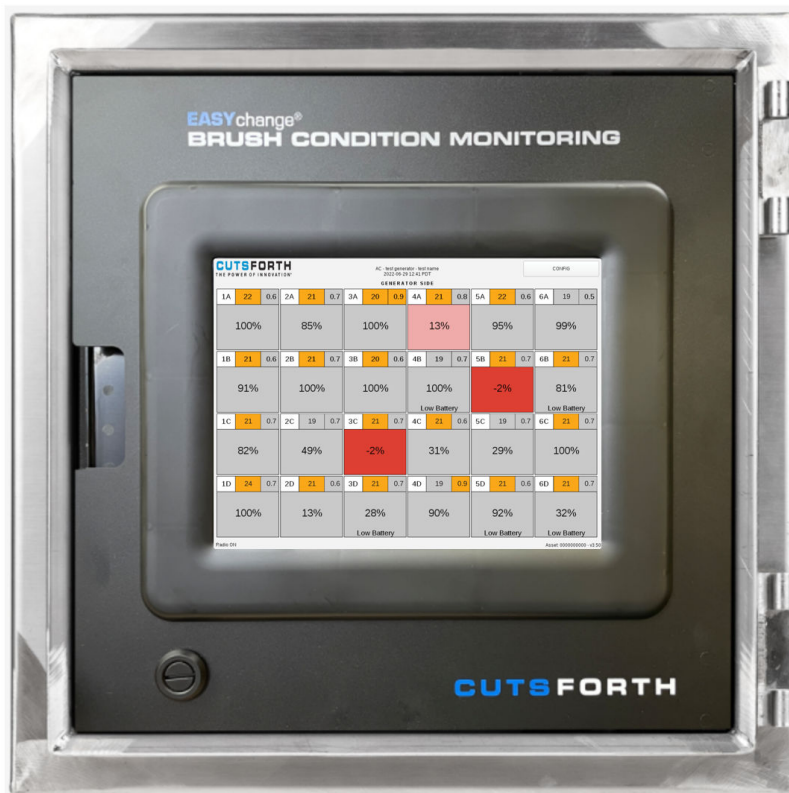

7. Brush Condition Monitoring System Installation

This section covers the installation process of the Brush Condition Monitoring System and the routing of the antenna signal wire. Before beginning the installation, thoroughly review the Brush Condition Monitoring System Installation Planning Guide (EZDP-2061). The major installation steps consist of:

1. [Mounting the Brush Condition Monitoring System Enclosure \(page 17\)](#)
2. [Running Power to the Brush Conditioning Monitoring System \(page 18\)](#)
3. [Route the Antenna Cabling \(page 19\)](#)
4. [Install Brush Holder Label Clips \(page 20\)](#)

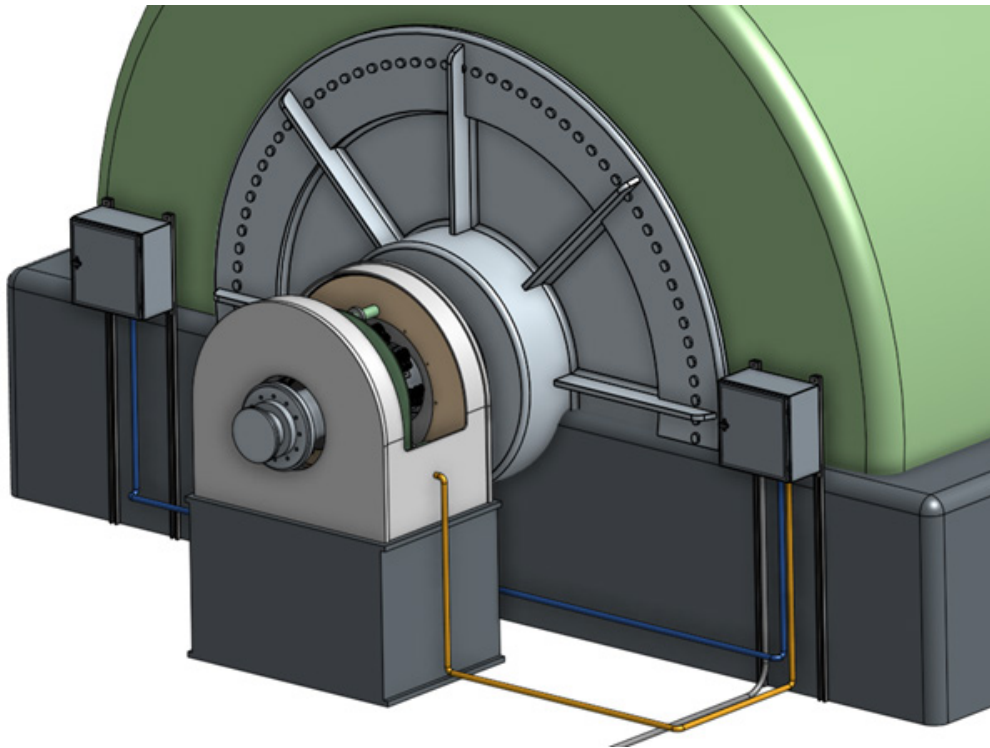

7.1. Mounting the Brush Condition Monitoring System Enclosure

This section covers the placement and mounting requirements for the Brush Condition Monitoring System enclosure.

7.1.1. Brush Condition Monitoring System Mounting Requirements

The Brush Condition Monitoring System **(A)** requires a minimum of two Unistrut rails **(B)** for mounting. Mount the enclosure as close to the exciter brushes as possible, while maintaining operator safety, to optimize the user experience. If desired, an optional auxiliary display **(C)** can be installed on the opposite side of the shaft from the primary enclosure. The auxiliary display uses the same enclosure and has the same mounting requirements as the primary enclosure.

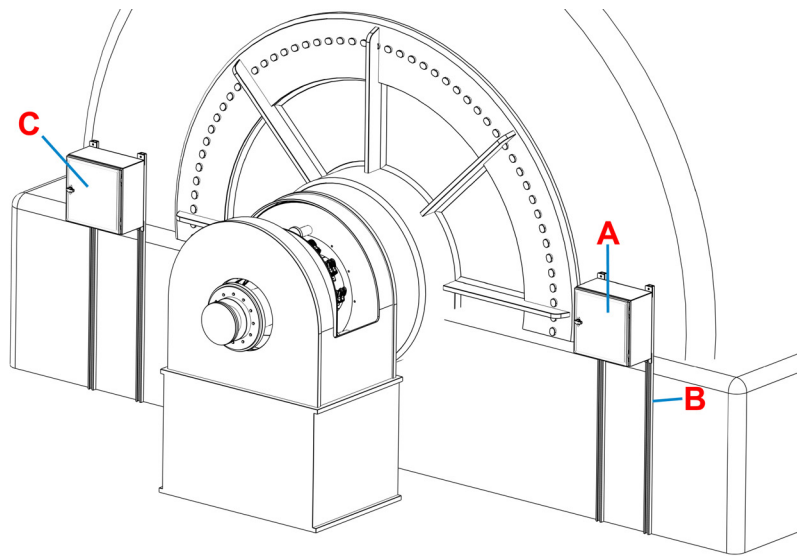

7.2. Running Power to the Brush Conditioning Monitoring System

The Brush Condition Monitoring System has an internal enclosed AC/DC converter which requires power input of 85–264 VAC at 47–63 Hz. The power output of the internal power supply is 24V, 6.25A DC (150W max). The power input cabling should be run to the Brush Condition Monitoring System in liquid-tight conduit (A). If installing the auxiliary display, liquid-tight conduit should be run between the enclosures to run power, display, and serial cables (B).

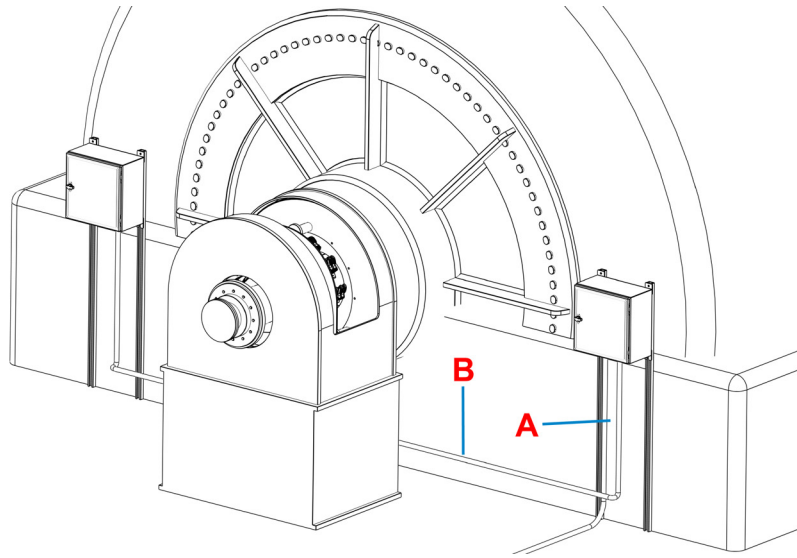

7.3. Route the Antenna Cabling

The Brush Condition Monitoring System requires the use of an antenna to enable ideal communication to and from the Brush Health Sensors. The ideal antenna mounting location may vary between installations. If you are unsure about the placement of the antenna, refer to the [Antenna Placement Mode \(page 45\)](#) section of this manual.

In most cases, the ideal antenna location will be inside the exciter housing. If this is the case:

1. Drill a hole through the lower portion of the exciter housing **(A)**.
2. Mount the antenna to the inside of the exciter housing with its connector extending through the newly drilled hole.
3. On the outside of the exciter housing, route liquid-tight conduit from the antenna to the Brush Condition Monitoring System **(B)** to run the antenna cable **(C)**.

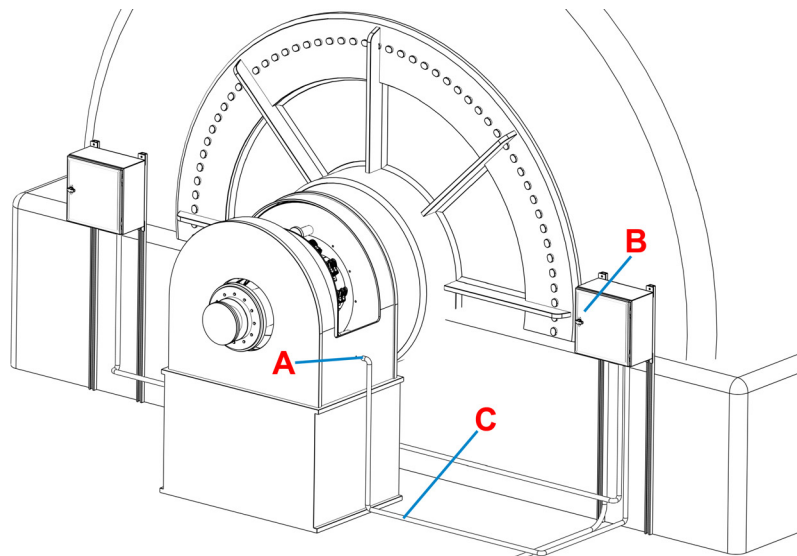

7.4. Install Brush Holder Label Clips

Installing brush holder label clips can assist in easily identifying brush positions as they relate to the Brush Condition Monitoring System display. The label clips often use an alphanumeric nomenclature to identify the row and path of each brush. For example, brush '2B' would refer to the brush located in row '2' and path 'B'.

To install the label clips:

1. Orient the label clips **(A)** as shown.

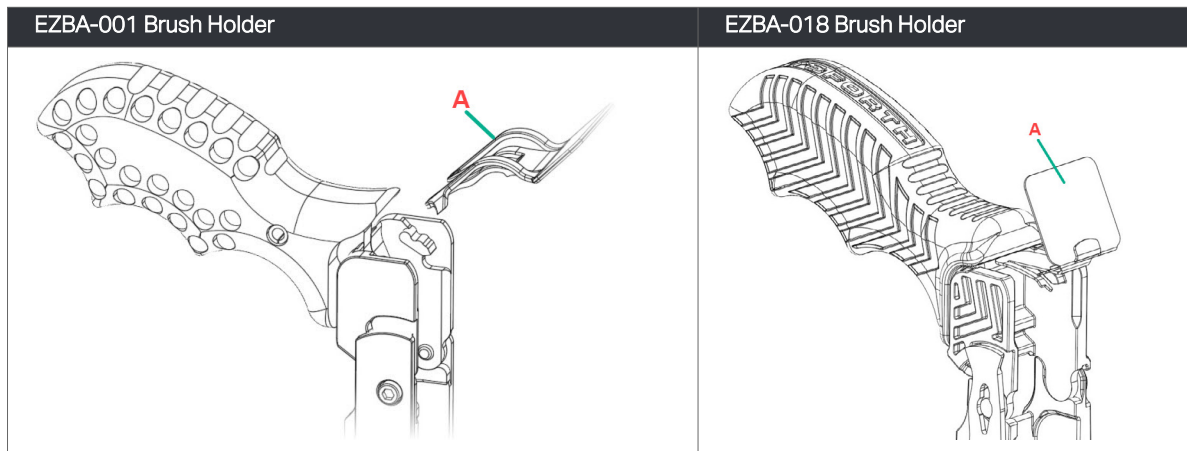

2. Guide the label clip **(A)** under the brush holder handle until you feel the label clip lock into place. The final resting position is shown here:

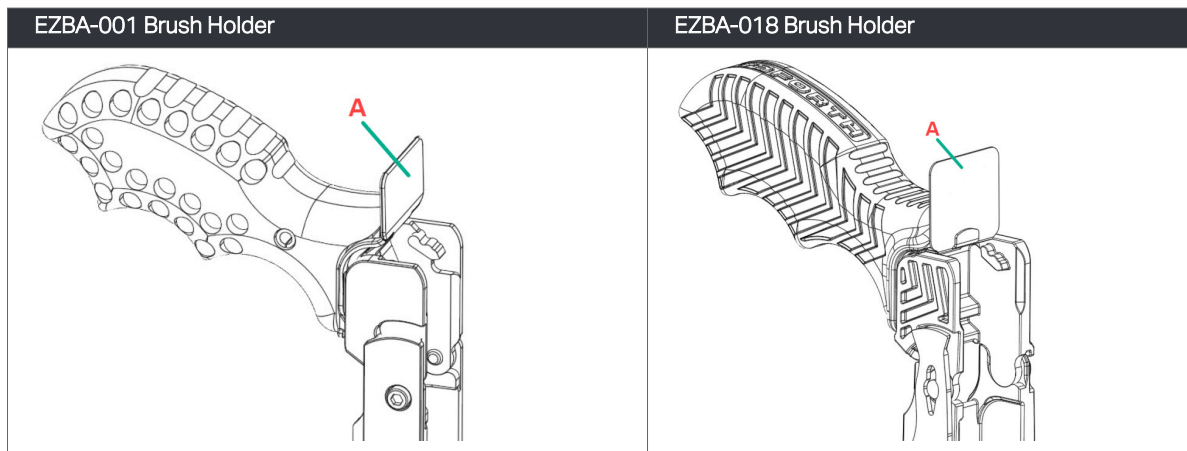

8. Brush Health Sensors

The Brush Health Sensor (BHS) is a data logging device that processes sensor data and reports it back to the Sensor Controller at a regular interval over a 2.4 GHz wireless link. Up to 216 Brush Health Sensors may be connected to a single monitoring system. The 2.4 GHz antenna is a PCB trace style antenna.

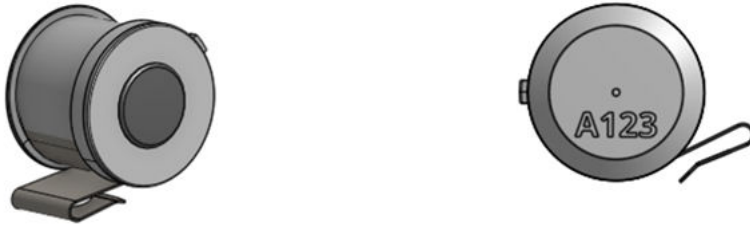

8.1. Pair a New Sensor

To pair a new sensor:

1. From the home screen, select the brush holder location where you want to place the new sensor.
2. When that brush holder location's menu appears, push **Press to Pair New Sensor**.

Brush Details

Location: 3D

Disable

Alternate Color

Press to Pair
New Sensor

90%

Brush Life
Remaining

0.6

Mils Pk-Pk

19

Celsius

Clear Brush
Length Warnings

Sensor Pairing Date 2022-08-17 10:06:41 PDT

Sensor Pairing Age (days)	0
Measurement Count	3
Brush Install Date	UNKNOWN
Brush Age (days)	UNKNOWN

Recent Displacements	1.0	1.0	1.1	-	-	-
Recent Temperatures	19	18	18	-	-	-

3. Press the button on the sensor you wish to pair.
4. Wait until a "pairing successful" message is returned.
5. Once pairing has successfully completed, install the brush and sensor in the proper position on the collector ring.



SENSOR NOT PAIRING? FOLLOW THESE STEPS:

- If a confirmation message does not appear, that sensor could be paired to another location.
- You can check if the sensor is paired somewhere else by following the instructions under first FAQ question.
- If you want to relocate the sensor to a different holder or location, or have confirmed the sensor is not paired with another location, simply unpair the sensor and repeat the pairing process.
- Still unable to pair the sensor? Submit a support request at Cutsforth.com/Support.

8.2. Frequency of Sensor Updates

Sensors are factory programmed to update data and communicate with the Primary Controller once every hour. However, the operator can manually wake up the sensor at any time by pressing the button **(A)** on the sensor. This forces the Primary Controller to collect data from that sensor at that time. The frequency of the automatic sensor data updates can be adjusted from the Advanced Configuration screen.

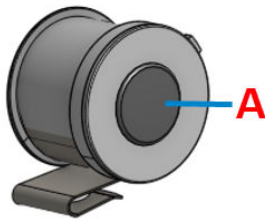

8.3. Unpair a Sensor

To unpair a sensor, press and hold the button on the sensor for three seconds until the two LEDs on the sensor flash three times.

This indicates that the sensor has been unpaired. The data for that sensor/location will remain visible on the Primary Controller home page until the next regular data collection interval passes. At that point, the Primary Controller home screen will update accordingly.

8.3.1. Replacing a Brush

Follow the standard EASYchange® process to change the brush. Provided that the Brush Health Sensor (BHS) still has battery life, the existing sensor-spring assembly can be reinstalled with the new brush.

Visit Cutsforth.com/BrushChange for video instructions.



REMINDER:

After the replacement brush is installed into the holder; short-press the BHS button one time, to reset the brush length data.

8.4. Brush Health Sensor Battery Life

The power source for the device is three Panasonic BR1632A lithium metal primary batteries soldered into the device. In the case of a low battery in a Brush Health Sensor, the Brush Condition Monitoring System will display a low battery warning. At that point, the sensor will have roughly 30 days of battery life remaining.

Operational Battery Life: 2 Years (Will vary depending on user-defined measurement interval as well as operating environment)

8.5. Button-On Self Test

The Brush Health Sensor contains self-test logic that allows the user to perform a single button press on the sensor and receive a status code in the form of number of LED flashes.

LED Flashes	Status Code
1	Success
2	Battery voltage error
3	Accel comm error
4	Accel functional error
5	Magnetic encoder comm error
6	Temperature error
7	Application error

9. Using the Primary Controller System User Interface

Before powering the Primary Controller on, first inspect the system to ensure that there are no foreign materials inside the enclosure, no damaged components, or loose wire connections.

9.1. Power On the Primary Controller

To power on the Primary Controller

1. Swing open the faceplate panel of the Primary Controller.
2. Locate the switch towards the bottom of the panel and flip it to the "ON" position.
3. Close the faceplate panel and wait for the system to boot and automatically load the monitoring application.

9.2. Primary Controller System Screen Layout

The diagrams in this section illustrate how the Primary Controller screen layout correlates to the brushes on your generator. The Advanced Configuration screen contains an option to select the generator reference label location. This allows the user to arrange the home screen in a way that makes the most sense for their unit configuration and the Primary Controller mounting location.

This is the Primary Controller screen layout. The below example shows the generator reference label location at the top of the screen.

CUTSFORTH		example plant Siemens - example generator - example name 2022-08-17 12:51 PDT										CONFIG					
GENERATOR SIDE																	
1A	24	0.7	2A	22	0.7	3A	21	0.6	4A	21	0.7	5A	21	0.8	6A	21	0.7
100%			100%			82%			97%			100%			100%		
1B	20	0.6	2B	21	0.7	3B	20	0.6	4B	21	0.7	5B	20	0.8	6B	22	0.7
100%			89%			100%			100%			90%			92%		
1C	23	0.8	2C	19	0.7	3C	19	1.0	4C	21	0.7	5C	22	0.9	6C	21	0.7
85%			100%			84%			100%			100%			91%		
1D	23	0.7	2D	25	0.8	3D	19	0.6	4D	25	0.9	5D	21	0.9	6D	20	0.6
84%			98%			90%			100%			81%			84%		

Radio ON LEFT RIGHT Asset: 000000000 - v3.50

The following diagrams show the brushes with the left (blue) and right (red) rows highlighted.

Generator Side



Generator Side

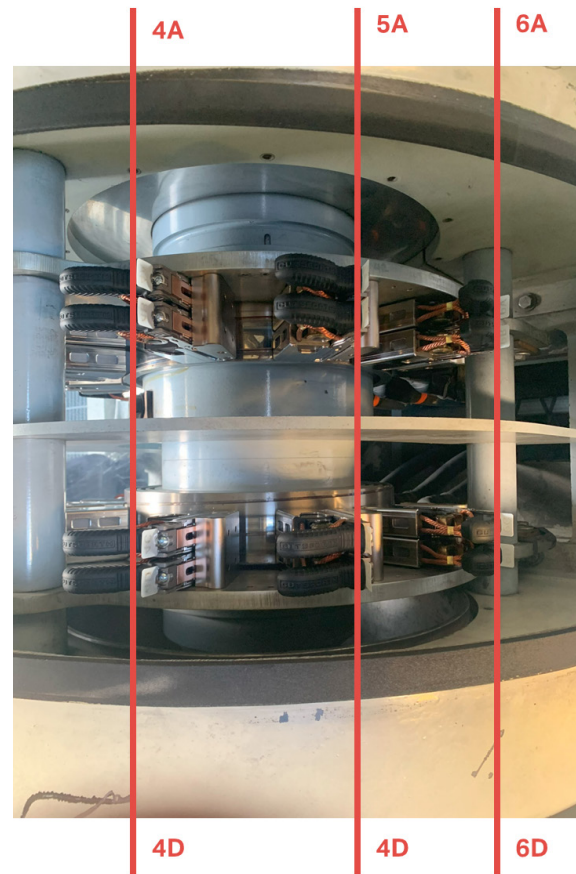

9.3. Navigating the Primary Controller Screen

Once the Primary Controller has been powered on, the top level view of the user interface screen appears:

- The **Config** button (A) opens the primary configuration window.
- Information in the top center of the user interface screen (B) shows plant name, generator manufacturer, name and type, and current time; all of which can be modified within Advanced Configuration.
- Asset tag and Brush Condition Monitoring Application version are shown in the bottom right corner (C).

CUTSFORTH THE POWER OF INNOVATION™																	
example plant Siemens - example generator - example name 2022-08-17 12:51 PDT																	
CONFIG																	
GENERATOR SIDE																	
1A	24	0.7	2A	22	0.7	3A	21	0.6	4A	21	0.7	5A	21	0.8	6A	21	0.7
100%			100%			82%			97%			100%			100%		
1B	20	0.6	2B	21	0.7	3B	20	0.6	4B	21	0.7	5B	20	0.8	6B	22	0.7
100%			89%			100%			100%			90%			92%		
1C	23	0.8	2C	19	0.7	3C	19	1.0	4C	21	0.7	5C	22	0.9	6C	21	0.7
85%			100%			84%			100%			100%			91%		
1D	23	0.7	2D	25	0.8	3D	19	0.6	4D	25	0.9	5D	21	0.9	6D	20	0.6
84%			98%			90%			100%			81%			84%		

Radio ON Asset: 0000000000 - v3.50

9.4. Power Off the Primary Controller

To power off, repeat the power on sequence in reverse order.

Another option for power off is to:

1. Plug in an external USB keyboard.
2. Press **ALT+F4** to close out of the application.
3. Press **ALT+F4** again to bring up the Power menu.
4. Select your desired option (shut down, restart, etc.).
5. If shutting down, wait for the system to fully shut down, then open the faceplate panel and flip the switch to the OFF position.

10. Connecting an Auxiliary Display

Some installations may make use of an auxiliary display, which is a fully-functioning duplication of the primary display that can be placed at a secondary location near the brush rigging if desired.

Three connections are required for the auxiliary display:

- 24V DC Power
- Touchscreen Signal over Ethernet
- Video over Ethernet

11. Brush Status Indication

The individual brush status indicators provide the following information:

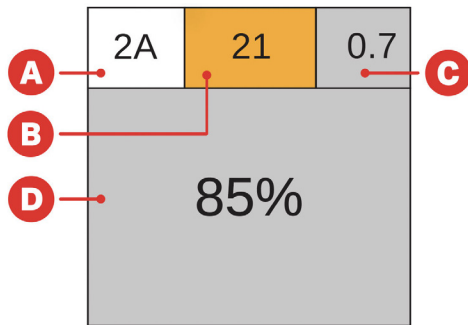

- A Location**
- B Temperature** (Peak Average in Degrees Celsius)
- C Brush Vibration/Displacement** (Mils Peak-to-Peak)
- D Usable Brush Life Remaining**

11.1. Color Definitions

The background color of the brush status indicator area changes depending on the remaining brush length:

- Red indicates the remaining brush length is less than or equal to 0%
- Pink indicates that the remaining brush length is less than or equal to the threshold set in the Configuration window

The background color of the displacement or temperature areas will be orange if the brush displacement or temperature value is greater than or equal to the associated threshold set in the Configuration window.

This figure shows possible background colors for different areas of the brush status indicator:

1A		2A		3A		4A		5A		6A	
22	0.6	21	0.7	20	0.9	21	0.8	22	0.6	19	0.5
100%		85%		100%		13%		95%		99%	
1B		2B		3B		4B		5B		6B	
21	0.6	21	0.7	20	0.6	19	0.7	21	0.7	21	0.7
91%		100%		100%		100%		-2%		81%	
						Low Battery				Low Battery	
1C		2C		3C		4C		5C		6C	
21	0.7	19	0.7	21	0.7	21	0.6	19	0.7	21	0.7
82%		49%		-2%		31%		29%		100%	
1D		2D		3D		4D		5D		6D	
24	0.7	21	0.6	21	0.7	19	0.9	21	0.6	21	0.7
100%		13%		28%		90%		92%		32%	
				Low Battery				Low Battery		Low Battery	

Radio ON

Asset 0000000000 - v3.50

12. Configure the Brush Condition Monitoring System Settings

The following settings can be changed in the Configuration window:

- Brush Alert Length



At this level the location background color will change to pink.

- Displacement Fault Maximum



At this level the displacement background color will change to orange.

- Temperature Fault Maximum



At this level the temperature background color will change to orange.

To configure the Brush Condition Monitoring System settings:

1. Press **Config (A)** to open the Configuration window.

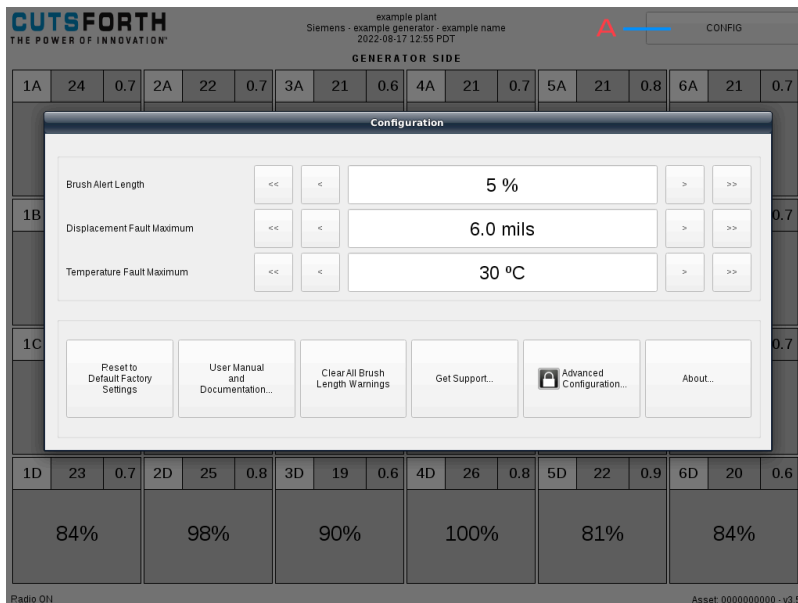

2. Click anywhere on the shaded area outside of the Configuration window to close it. If any settings have changed, a Save changes dialog appears.

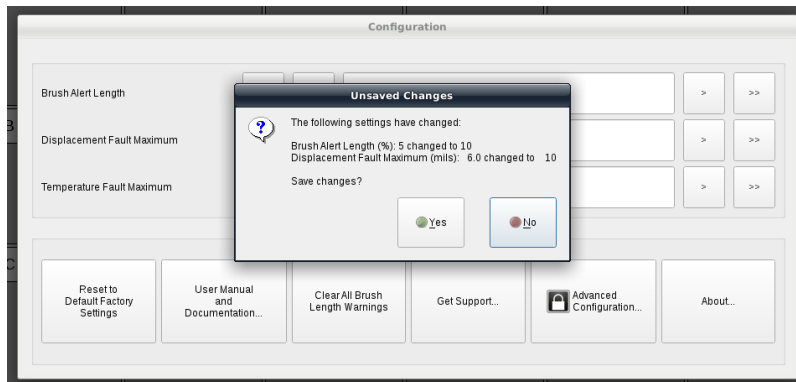

13. Advanced Configuration Settings



Some of the steps in these sections will require the use of a USB keyboard, USB mouse, and/or a USB storage drive. The use of a USB hub or splitter is often beneficial.

The Advanced Configuration window provides an option for the operator to:

- [Export Data and Event Logs \(page 37\)](#)
- [Update the Brush Condition Monitoring Application \(page 38\)](#)
- [Update the Brush Health Sensor Firmware \(page 39\)](#)
- [Set the Brush Condition Monitoring System Time \(page 40\)](#)

13.1. Access the Advanced Configuration Window

1. Press Config **(A)**.
2. Press Advanced Configuration **(B)**.

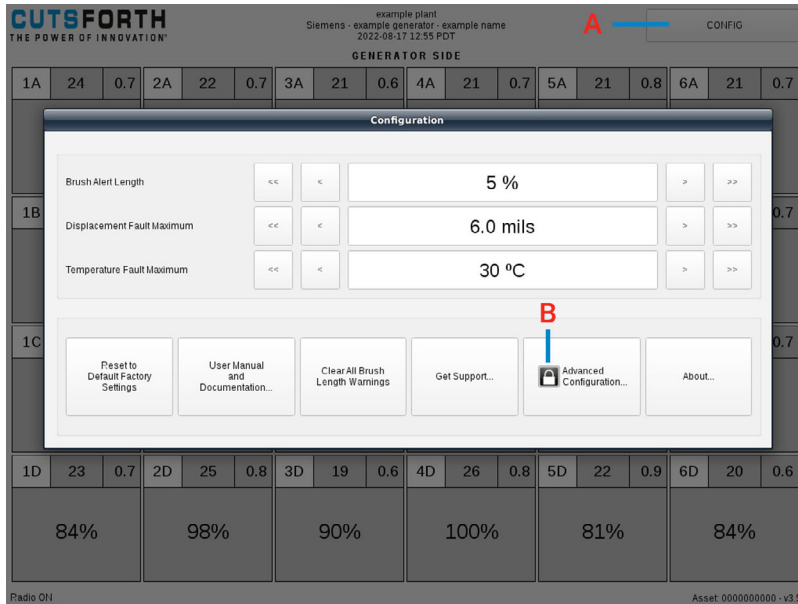

3. Enter the administrative password to open the Advanced Configuration window. Contact support@cutsforth.com for access information.

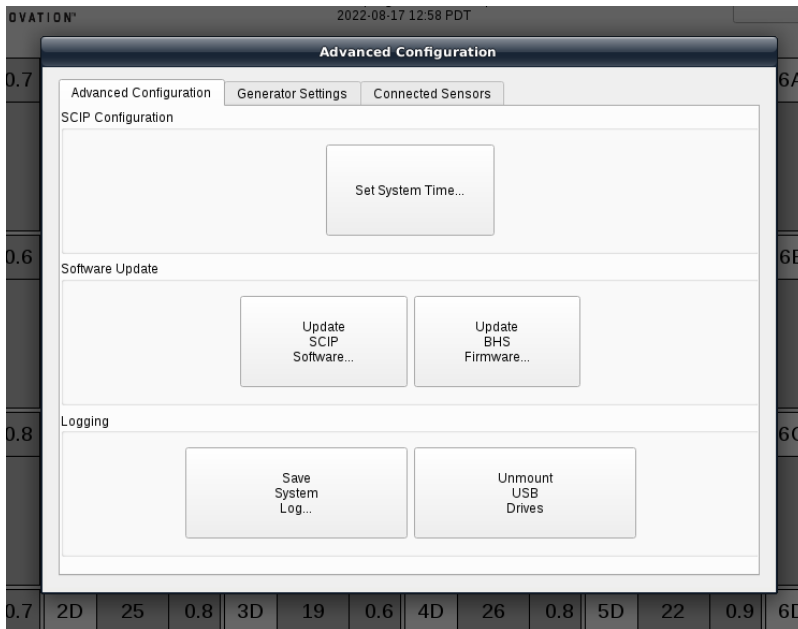

13.2. Export Data and Event Logs

1. Plug in a USB drive.
2. Press **Save System Log (A)**
3. Select the sdb1 folder **(B)**.
4. Press **Choose (C)**. This exports historical data logs to a .csv file and system event logs in the form of .txt files.

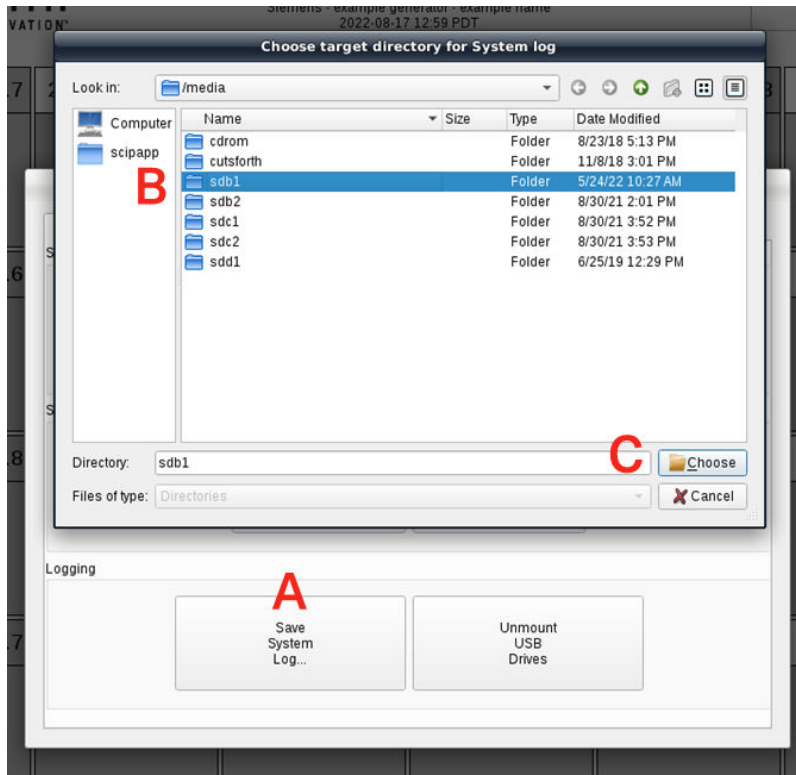

13.3. Update the Brush Condition Monitoring Application

To update the Brush Condition Monitoring Application utilizing an external USB device loaded with new software:

1. Plug in a USB drive with the new Brush Condition Monitoring Application.
2. Press **Update SCIP Software (A)**.
3. Open the sdb1 folder and navigate to ScipApp binary.
4. Select **ScipApp binary (B)** and press **Open (C)**.
5. The Brush Condition Monitoring Application will restart.

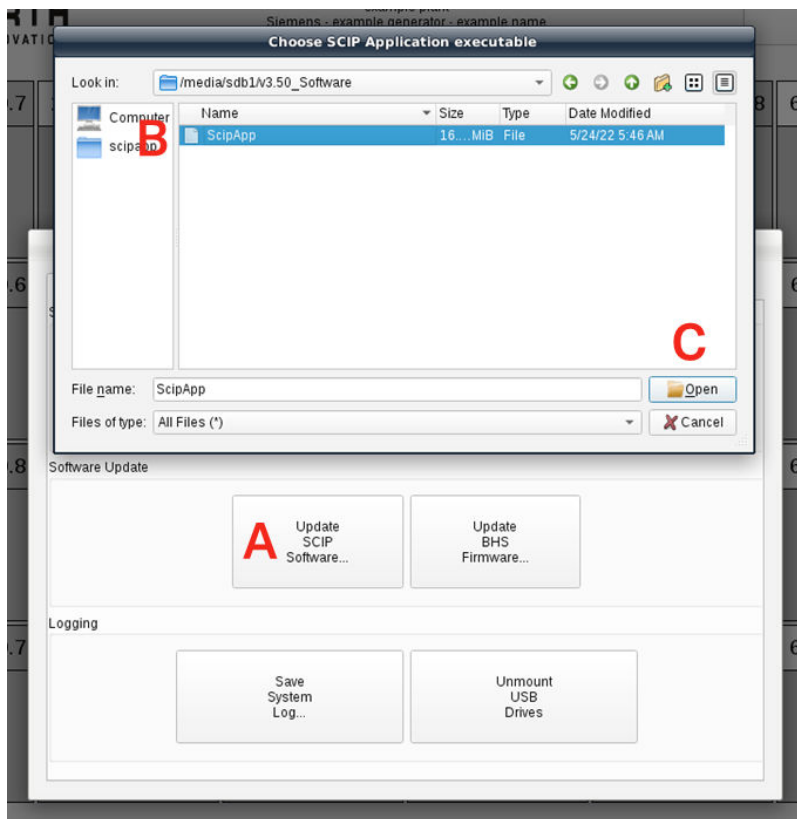

13.4. Update the Brush Health Sensor Firmware

To update the sensor firmware:

1. Plug in a USB drive with the new firmware.
2. Press **Update BHS Firmware (A)**.
3. Open the sdb1 folder and navigate to the latest firmware binary.
4. Select the firmware binary **(B)** and press **(C)**.
5. The application imports the new firmware and stages it for update.

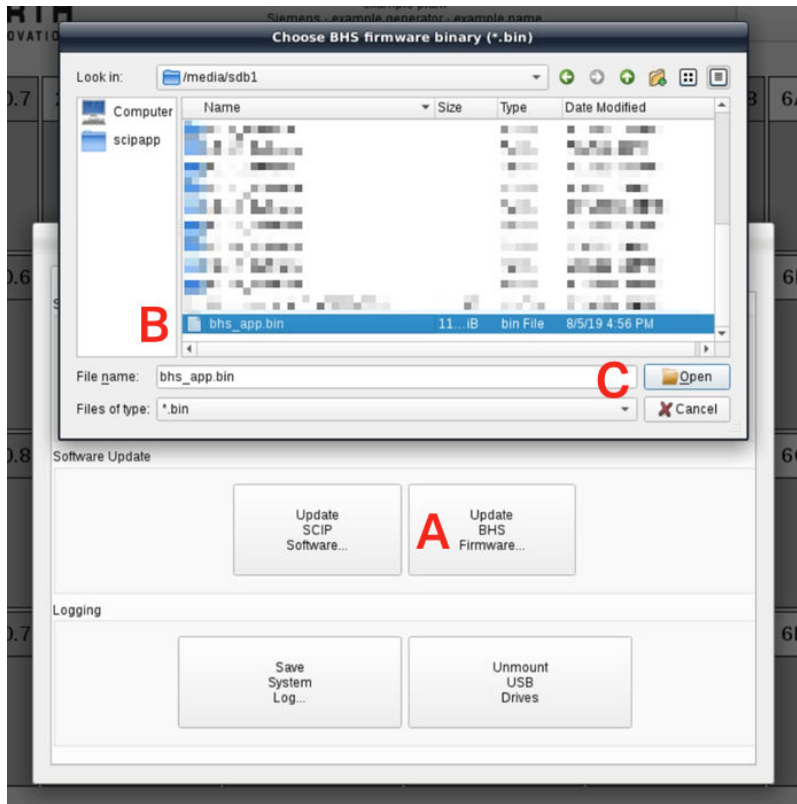

13.5. Set the Brush Condition Monitoring System Time

To set the Brush Condition Monitoring System time:

1. Press **Set System Time (A)**.
2. Press **Time Zone (B)**.



Automatic Time Zone must be turned off in order to manually set the time zone.

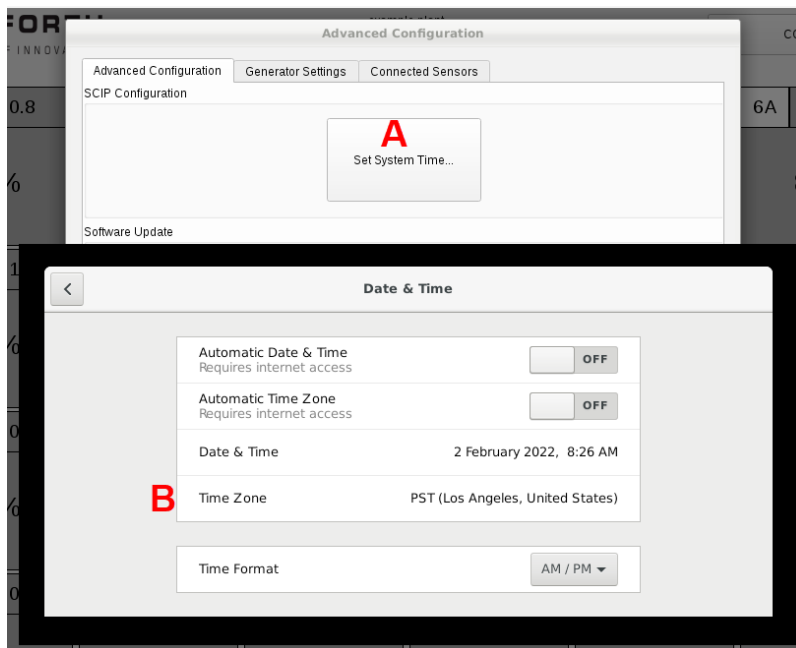

3. Select a time zone by pressing on the map or by entering a city name in the search bar and selecting from the drop-down list.

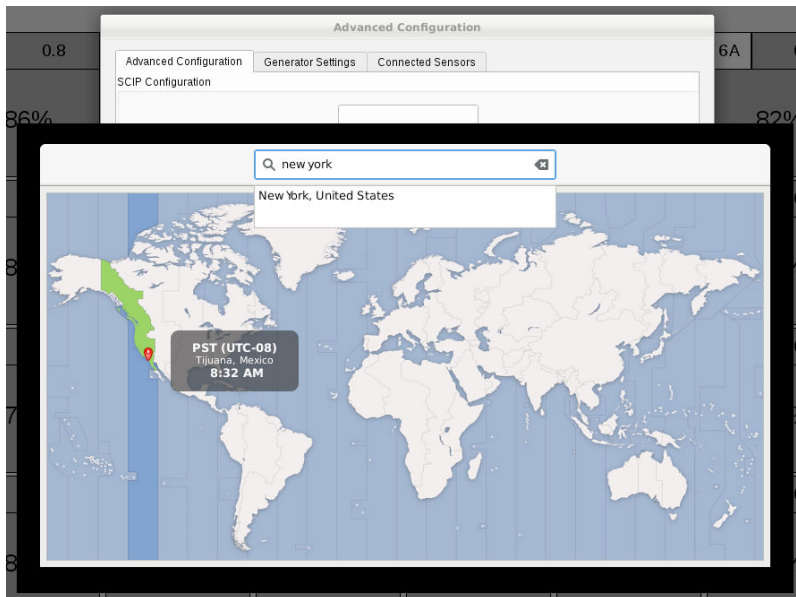

4. Press **Alt + F4** to close the Time Zone Selection window.
5. Press **Date and Time (C)**.



Automatic Date and Time must be turned off in order to manually set the date and time.

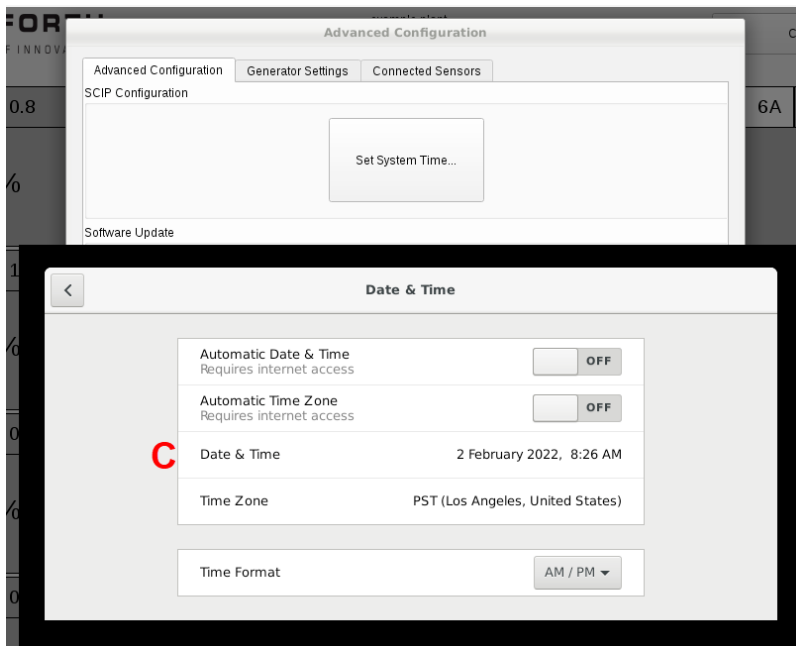

- Set the date and time and press the **Esc** key to close the date and time editor.

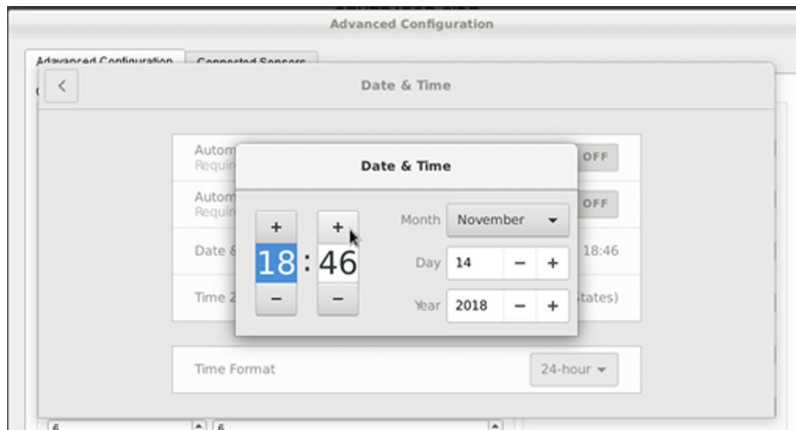

- Press **Alt + F4** to close the Date and Time window and return to the Advanced Configuration Window.
- Click anywhere on the shaded area outside of the Advanced Configuration window to close it.

14. Generator Settings

To access the Generator Settings page, enter the Advanced Configuration screen and navigate to the Generator Settings tab. The following settings can be changed from this page:

- Plant name
- Generator manufacturer, type, and name
- Location of on-screen generator reference label
- Measurement interval (how often sensors will report data)
- Number of brushes (number of rows and number of columns)
- Brush numbering label display type (alphanumeric vs. numeric)
- Modbus TCP port
- Modbus RTU serial interface settings



Some of the steps in these sections will require the use of a USB keyboard, USB mouse, and/or a USB storage drive. The use of a USB hub or splitter is often beneficial.

Advanced Configuration

Advanced Configuration
Generator Settings
Connected Sensors

Generator Information

Plant

Generator Manufacturer

Generator Type

Generator Name

Generator Location

Measurement Interval

Num. Brush Rows

Num. Brush Columns

Label Display Type

Asset Tag

Modbus - ttyS2 and ttyS3

TCP Port

Server Address

Baud Rate

Data Bits

Parity Bits

Stop Bits

Re-Initialize Modbus Ports

14.1. Measurement Interval

The Brush Condition Monitoring System collects data sets from the Brush Health Sensors (BHS) during regular measurement intervals. This measurement interval is a user-configurable setting from the Generator Settings page with options of 1, 3, 6, or 12 hours. Please note that battery life of the BHS is directly impacted with the frequency of data collection.

The screenshot displays the 'Advanced Configuration' web interface, specifically the 'Generator Settings' tab. The interface is divided into two main sections: 'Generator Information' and 'Modbus - tyS2 and tyS3'. The 'Generator Information' section includes fields for Plant, Generator Manufacturer, Generator Type, Generator Name, Generator Location, Measurement Interval, Num. Brush Rows, Num. Brush Columns, Label Display Type, and Asset Tag. The 'Modbus' section includes fields for TCP Port, Server Address, Baud Rate, Data Bits, Parity Bits, and Stop Bits, along with a 'Re-initialize Modbus Ports' button. The 'Measurement Interval' dropdown menu is highlighted with a red box, showing the following options: 1 hour, 3 hours, 6 hours, and 12 hours.

Field	Value
Plant	example plant
Generator Manufacturer	Siemens
Generator Type	example generator
Generator Name	example name
Generator Location	Top
Measurement Interval	1 hour
Num. Brush Rows	3 hours
Num. Brush Columns	12 hours
Label Display Type	Alphanumeric
Asset Tag	0000000000
TCP Port	501
Server Address	1
Baud Rate	19200
Data Bits	8
Parity Bits	Even
Stop Bits	1

15. Antenna Placement Mode



Sensor batteries will drain at a faster than normal rate during antenna placement mode.

To enter antenna placement mode, navigate to the Connected Sensors tab in the Advanced Configuration window and press **Antenna Placement Mode**.

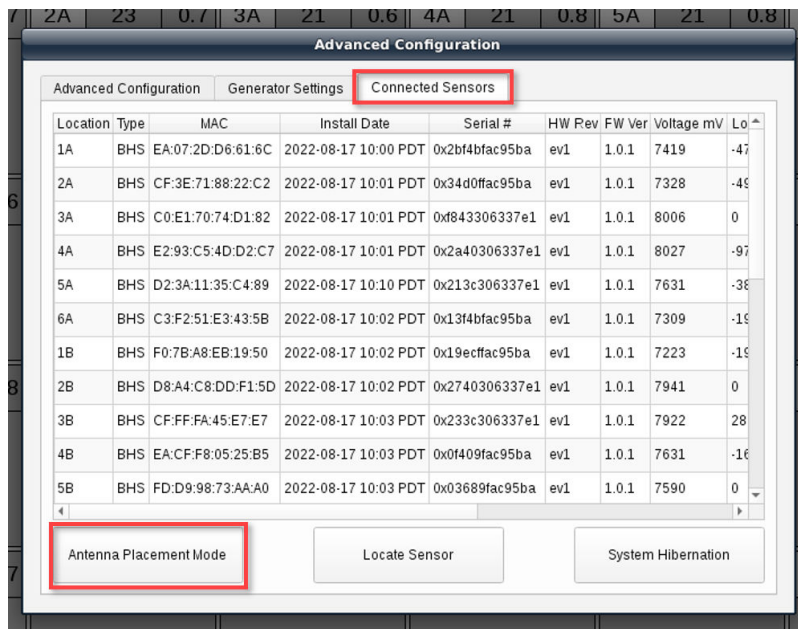

In antenna placement mode, brush status indicators show radio signal strength instead of sensor data. Background color changes depending on the strength of the radio signal:

- **Red:** Weak or unknown signal strength
- **Pink:** Moderate signal strength
- **Gray:** Strong signal strength

Two numbers are shown for every location:

- The left number is the signal strength on the Primary Controller side (quality of the radio link from sensor to the Primary Controller).
- The right number is the signal strength on the sensor side (quality of the radio link from Primary Controller to sensor).

Please allow around one hour for all sensors to report signal strength. To exit antenna placement mode, navigate back to the Connected Sensors tab in the Advanced Configuration window, and press **Antenna**

Placement Mode. To prevent excessive battery drainage, the BCM system will automatically quit antenna placement mode after two hours.

CUTSFORTH

example plant
 Siemens - example generator - example name
 2022-08-17 14:45 PDT

WARNING:
 ANTENNA
 PLACEMENT

CONFIG

GENERATOR SIDE

1A -54/-51	2A -52/-48	3A -53/-51	4A -53/-59	5A -50/-46	6A -60/-57
1B -53/-49	2B -53/-48	3B -50/-49	4B -47/-43	5B -53/-47	6B -58/-50
1C -59/-59	2C -54/-56	3C -57/-55	4C -54/-49	5C -50/-43	6C -49/-45
1D -50/-44	2D -49/-44	3D -57/-55	4D -54/-55	5D -54/-55	6D -50/-43

Radio ON
Asset: 0000000000 - v3.50

16. Modbus Interface

To convert the alphanumeric brush location tags to a numeric value that corresponds to the Modbus outputs, use the following schema: From smallest to largest: 1A, 2A, 3A,..., 1B, 2B, 3B,..., 1C, 2C, 3C, etc.



The Brush Condition Monitoring System should be configured as a slave device.

Refer to this table when programming the Modbus output on your BCM System:

Brush	Name	Value Type	Value Unit	Register Type	Address (Base 0)	Physical Address (Base 0)	Supported Functions
0–229	Sensor Low Batt	Boolean	Flag	Discrete Input	10000–10229	0x000–0x0E5	0x02 Read Discrete Input
0–229	Sensor Malfunction	Boolean	Flag	Discrete Input	10230–10459	0x0E6–0x1CB	0x02 Read Discrete Input
0–229	Replace Brush Now (Critical)	Boolean	Flag	Discrete Input	10460–10659	0x1CC–0x2B1	0x02 Read Discrete Input
0–229	Replace Brush Soon (Alert)	Boolean	Flag	Discrete Input	10690–10919	0x2B2–0x397	0x02 Read Discrete Input
0–229	High Vibration Warning	Boolean	Flag	Discrete Input	10920–11149	0x398–0x47D	0x02 Read Discrete Input
0–229	Sensor Sample Old	Boolean	Flag	Discrete Input	11150–11379	0x47E–0x563	0x02 Read Discrete Input
0–229	Temperature Critical	Boolean	Flag	Discrete Input	11380–11609	0x564–0x649	0x02 Read Discrete Input
0–229	Length Error	Boolean	Flag	Discrete Input	11610–11839	0x64A–0x72F	0x02 Read Discrete Input
0–229	Brush Length	Short	% Remaining	Input Register	30000–30229	0x000–0x0E5	0x04 Read Input Register
0–229	Pk-to-Pk Displacement	Word	0.001 mils	Input Register	30230–30459	0x0E6–0x1CB	0x04 Read Input Register
0–229	Temperature	Short	Degrees C	Input Register	30460–30689	0x1CC–0x2B1	0x04 Read Input Register

Brush	Name	Value Type	Value Unit	Register Type	Address (Base 0)	Physical Address (Base 0)	Supported Functions
N/A	System Status	Word	Bitfield: b0 : Hibernation Mode (1 - Enabled, 0 - Disabled) b1-15: RFU	Input Register	30920	0x398	0x04 Read Input Register
N/A	System Time	Word	POSIX time (LSB - MSB)	Input Register	30921–30922	0x399–0x39A	0x04 Read Input Register
N/A	Short Brush Count	Word	Number of brushes that must be replaced immediately	Input Register	30923	0x39B	0x04 Read Input Register
N/A	Near-Short Brush Count	Word	Number of brushes that will need replacement soon	Input Register	30924	0x39C	0x04 Read Input Register
N/A	High Vibration Brush Count	Word	Number of sensors reporting high vibration	Input Register	30925	0x39D	0x04 Read Input Register
N/A	Sensor Error Count	Word	Number of sensors reporting errors	Input Register	30926	0x39E	0x04 Read Input Register
N/A	Low Battery Total	Word	Number of sensors reporting low battery	Input Register	30927	0x39F	0x04 Read Input Register
0–229	Battery Voltage	Word	Millivolts (mV)	Input Register	30928–31157	0x3A0–0x485	0x04 Read Input Register
0–229	RSSI Value	Word	Decibel milliwatts (dBm)	Input Register	31158–31387	0x486–0x56B	0x04 Read Input Register
0–229	BHS MAC address (lo byte, little-endian)	Word	N/A	Input Register	31388–31617	0x56C–0x651	0x04 Read Input Register
0–229	BHS MAC address (mid byte, little endian)	Word	N/A	Input Register	31618–31847	0x652–0x737	0x04 Read Input Register
0–229	BHS MAC address (hi byte, little-endian)	Word	N/A	Input Register	31848–32077	0x738–0x81D	0x04 Read Input Register

Brush	Name	Value Type	Value Unit	Register Type	Address (Base 0)	Physical Address (Base 0)	Supported Functions
0–229	SensorError Register with Sensor Error Flags	Word	N/A	Input Register	32078–32307	0x81E–0x903	0x04 Read Input Register
N/A	Old Samples Count	Word	Number of sensors reporting old samples	Input Register	32308	0x904	0x04 Read Input Register
N/A	Temperature Critical Count	Word	Number of sensors reporting critical temperature	Input Register	32309	0x905	0x04 Read Input Register
N/A	Length Error Count	Word	Number of sensors reporting brush length errors	Input Register	32310	0x906	0x04 Read Input Register

16.1. Entering a Static IP Address

1. Plug the USB keyboard into the BCM system.
2. Press **Alt+F2** to pull up the Application Finder.

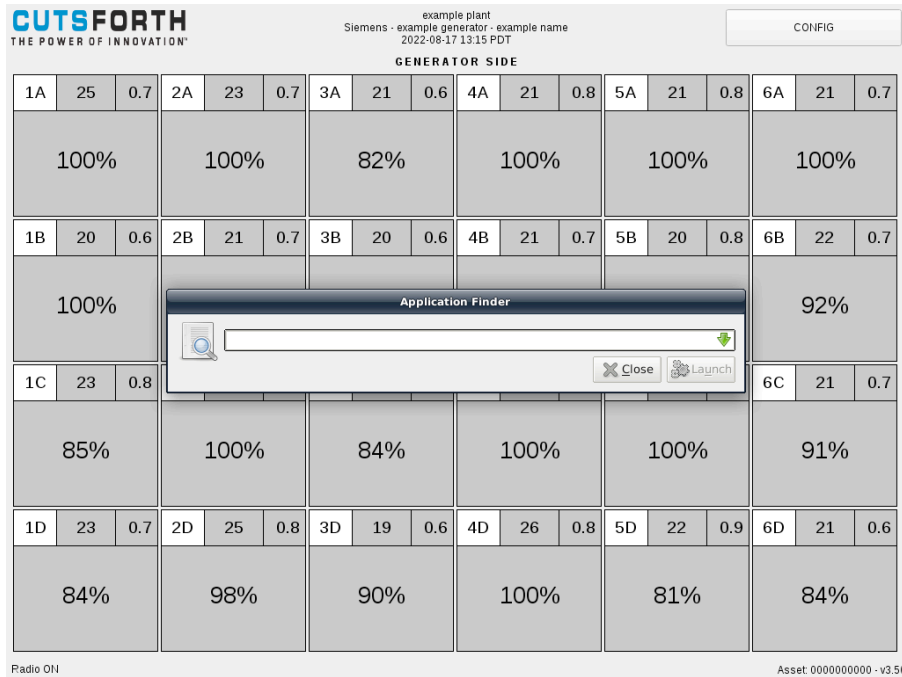

3. Click on the green arrow that is pointed down to display the window of options.

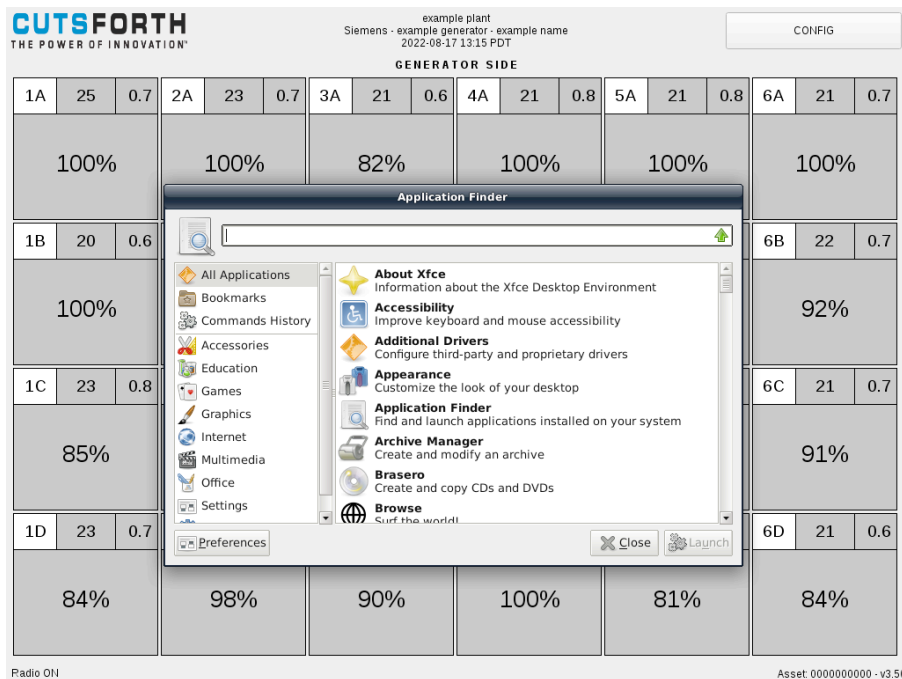

4. Scroll down, select **Network Connections**, and click **Launch**.



5. Double-click **Wired Connection 1**.

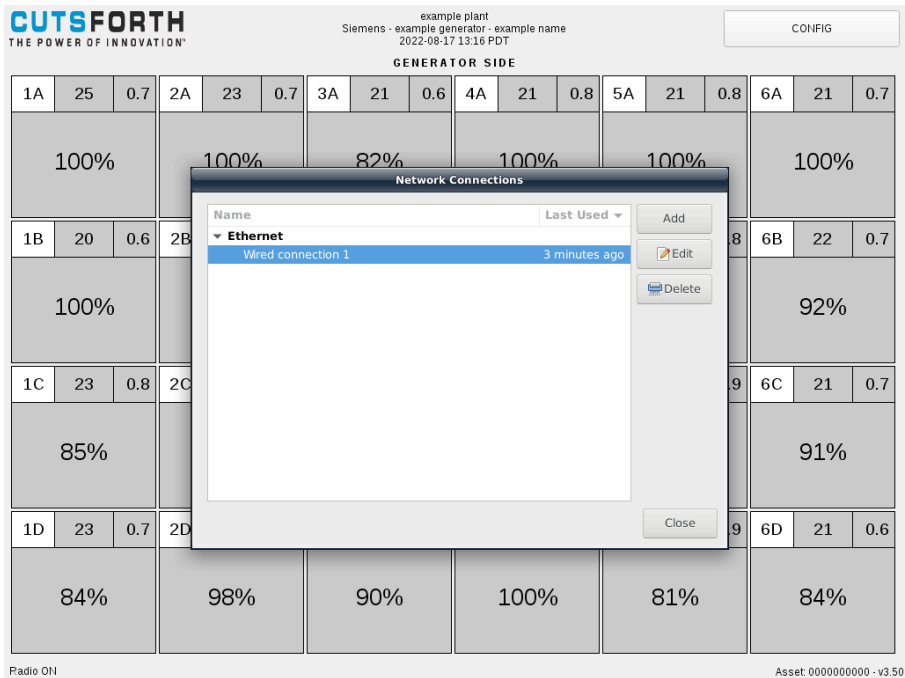

6. Select the **IPv4 Settings** tab.

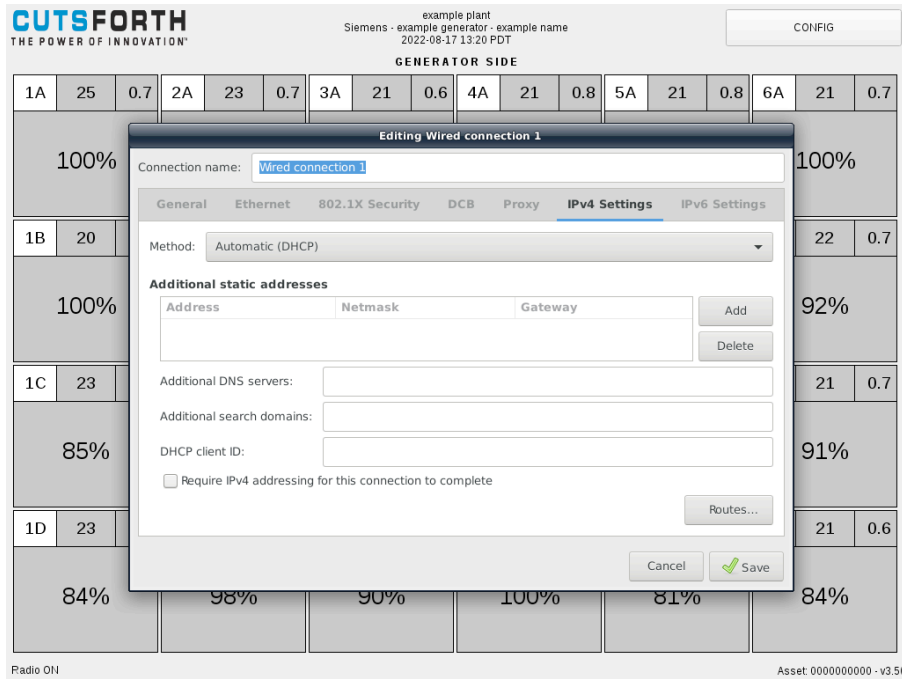

7. Under the Method drop-down, select **Manual** to change IP configuration settings to **static**.

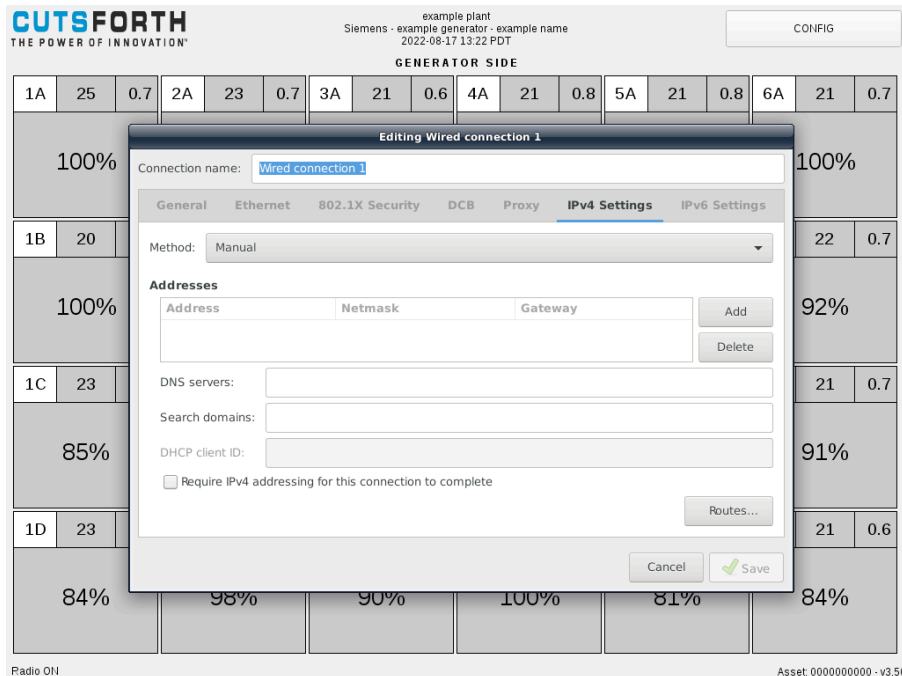

8. Click **Add**.

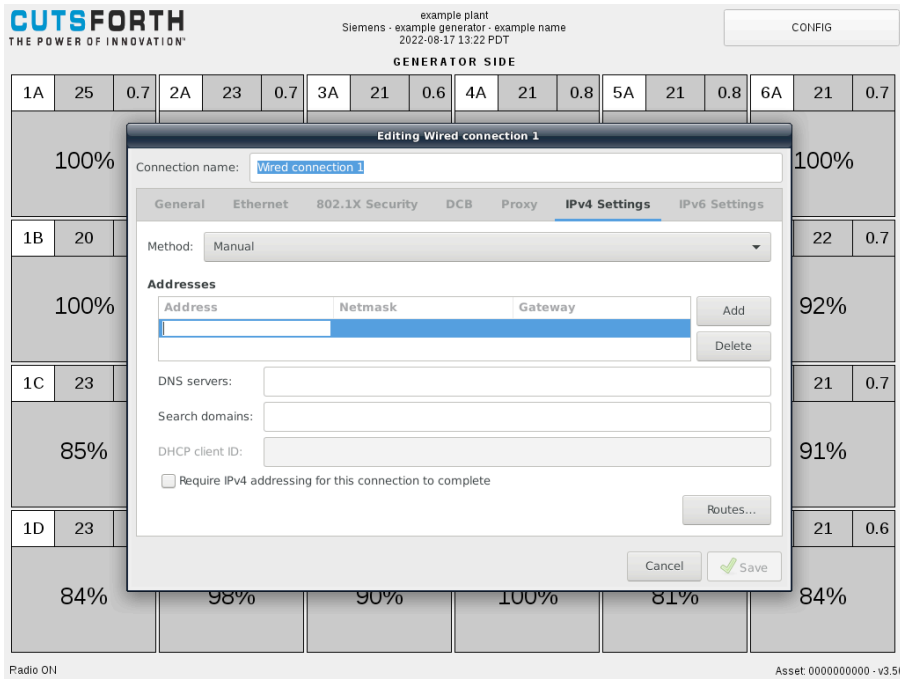

9. Enter the desired addressing information, and click **Save** when you are finished.

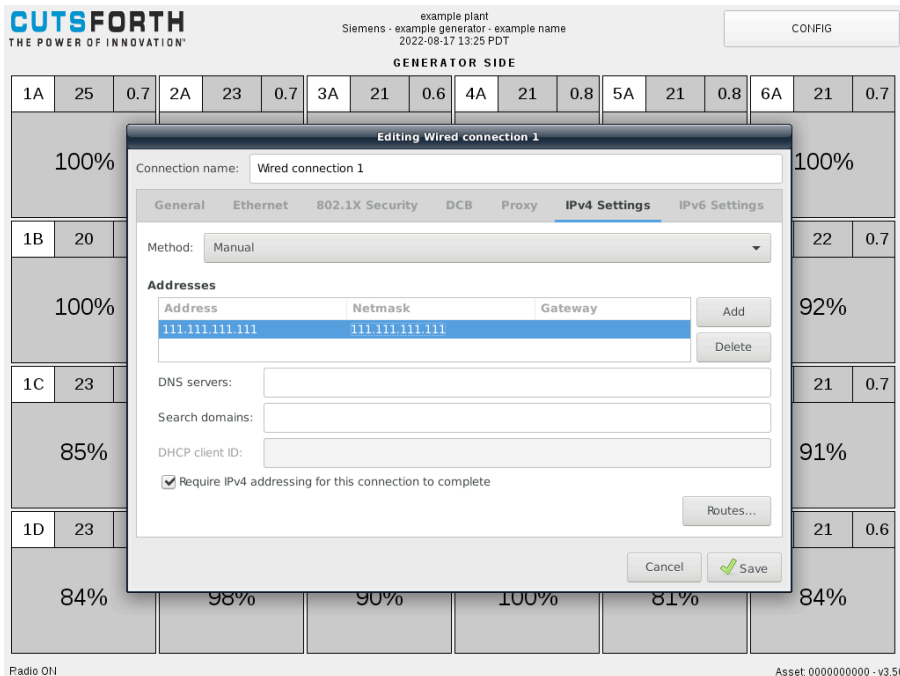

16.2. Locating the MAC Addresses

1. Connect a USB keyboard to the BCM system.
2. From the BCM Application Home Screen, press **CONFIG** in the upper-right corner.

GENERATOR SIDE																	
1A	24	0.7	2A	22	0.7	3A	21	0.6	4A	21	0.7	5A	21	0.8	6A	21	0.7
100%			100%			82%			97%			100%			100%		
1B	20	0.6	2B	21	0.7	3B	20	0.6	4B	21	0.7	5B	20	0.8	6B	22	0.7
100%			89%			100%			100%			90%			92%		
1C	23	0.8	2C	19	0.7	3C	19	1.0	4C	21	0.7	5C	22	0.9	6C	21	0.7
85%			100%			84%			100%			100%			91%		
1D	23	0.7	2D	25	0.8	3D	19	0.6	4D	25	0.9	5D	21	0.9	6D	20	0.6
84%			98%			90%			100%			81%			84%		

Radio ON Asset: 0000000000 - v3.50

3. At the bottom of the Configuration screen, press **Advanced Configuration**. When prompted, enter the administrative password.

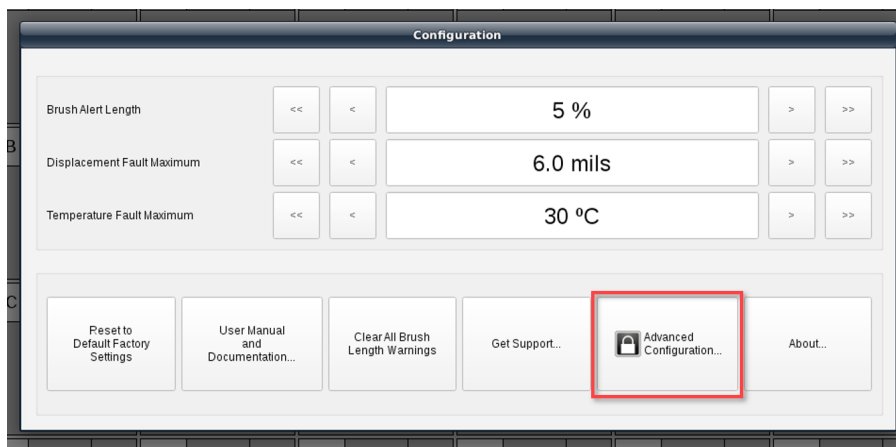

4. In the lower-right corner of the Advanced Configuration screen, press **Set System Time**.

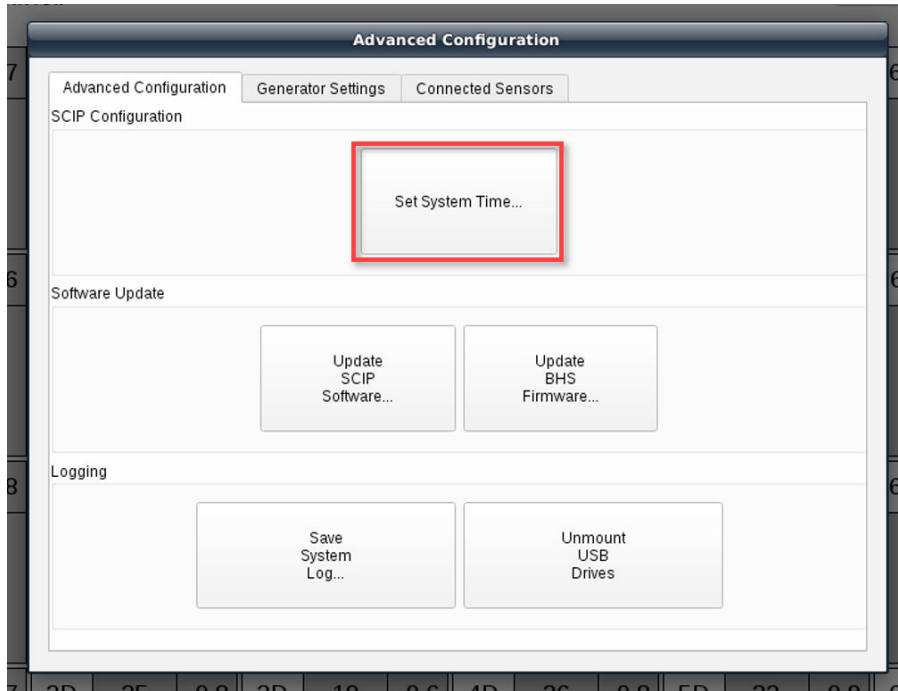

5. From the Data & Time screen, press the back button in the upper-left corner.

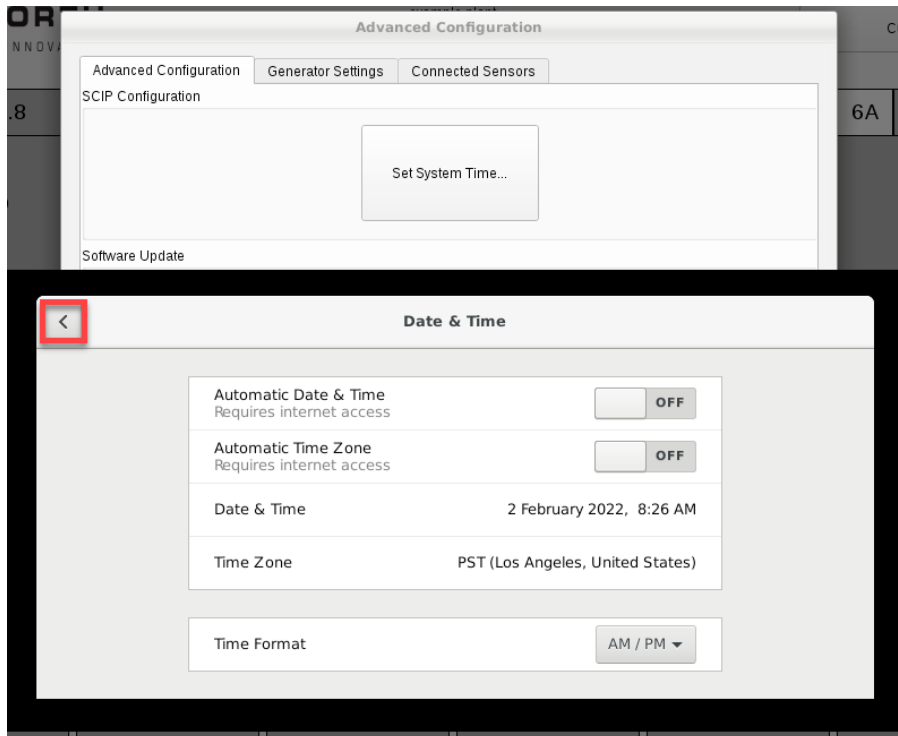

- From the All Settings menu, select **Network**.

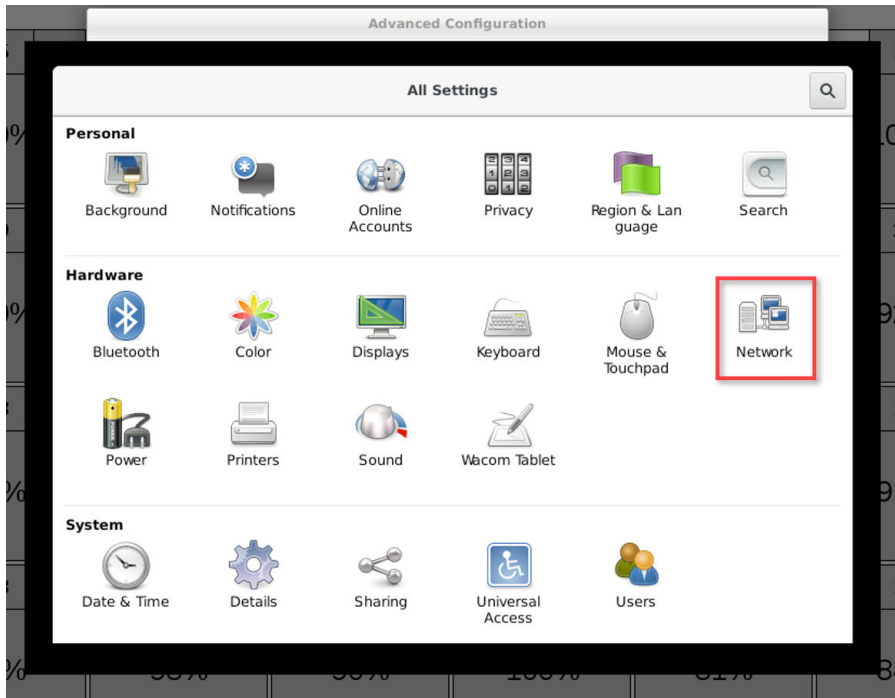

- The MAC addresses will be listed as "Hardware Address" under each "Ethernet" option in the list on the left hand side.

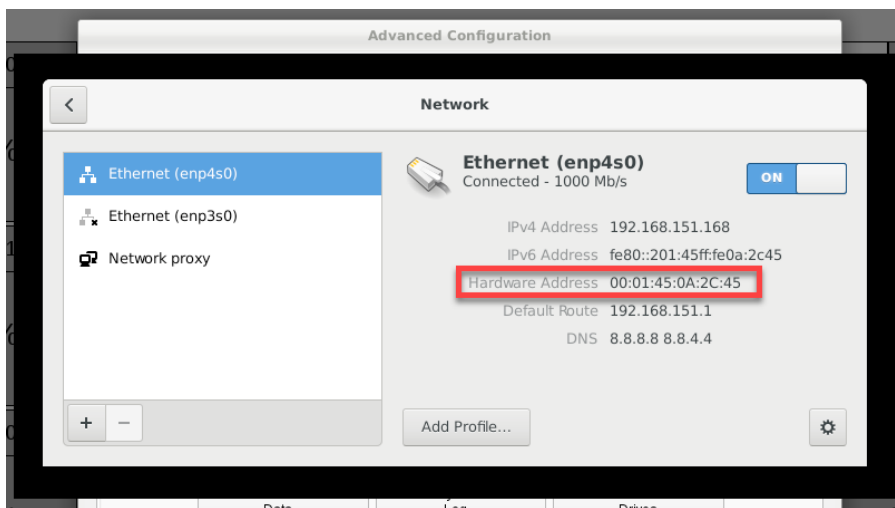

16.3. Modbus RTU Configuration

In addition to Modbus TCP/IP, the BCM System also supports Modbus RTU communication via either RS-232 or RS-485. If using Modbus RTU, confirm the serial ports are configured appropriately for either RS-232 or RS-485. This can be managed in the SIO Configuration settings within the BIOS menu. The BIOS menu can be accessed by pressing F2 during the bootup process.

A null modem cable is required if using RS-232.

The BCM System provides an RJ45 connection point for the Modbus RTU communications. The following table outlines the wiring pinouts for RS-232 and RS-485.

RJ45 Pin	RS-232	RS-485
1	DSR	Tx/Rx -
2	RTS	N/A
3	Shield	N/A
4	Tx	N/A
5	Rx	Tx/Rx +
6	GND	GND
7	CTR	N/A
8	DTR	N/A

17. Frequently Asked Questions (FAQ)

How can I confirm if a sensor is already paired and where it is paired to?

Return to the main screen of the controller, single-press the button on the BHS sensor in question and that sensor's brush location icon will flash with a blue border for a few seconds. If none of the brush location icons flash, that sensor is not paired to any of the brush location icons.

Can a new BHS be installed on a used brush?

Yes, both a new BHS and a used BHS with battery life remaining can be installed on new and partially used brushes alike. Remember, in both cases, to single-press the sensor button after the sensor and brush are installed in the holder, but before it is installed onto the generator, to reset the brush length data.

How long does a BHS battery last?

The expected battery life of the sensors is 2 years or longer and may vary depending on environmental conditions and the user-set measurement intervals. The brush location icon will show a low battery warning roughly 30 days prior to the end of the BHS battery life.

What is the "Clear Brush Length Warnings" button on the brush detail screen for?

When a brush length falls below the threshold set in the CONFIG screen, that brush data icon will turn pink, and then red if it falls below 0%. If the brush length is no longer below the user-set threshold, but the pink/red condition still persists, pressing this button will reset the icon back to gray.

What do the different color warnings mean in the Brush Data Icon?

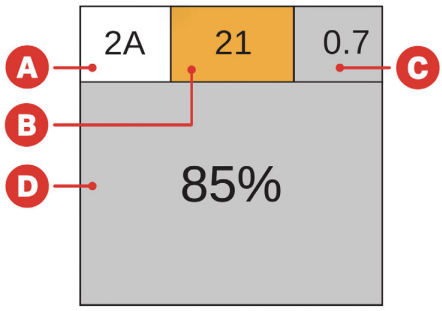
 <p>A Location B Temperature (Peak Average in Degrees Celsius) C Brush Vibration/Displacement (Mils Peak-to-Peak) D Usable Brush Life Remaining</p>	<p>Section C will turn orange when the vibration/displacement threshold is exceeded, which is set in the CONFIG screen under "Displacement Fault."</p> <p>Section D will turn pink when the usable brush life goes below the "Brush Alert Length" threshold, also set in the CONFIG screen. Then this section will turn red once the brush exceeds its usable life (0%).</p>
--	--

What do I do if I see "No Data" on a brush location icon?

Attempt the following troubleshooting steps in this order:

1. Press the button on the associated sensor once, and watch the BCM screen to see if the location in question updates with data within a few seconds.
2. Unpair and re-pair the BHS following the instructions under Pairing a Brush Health Sensor, then wait for the measurement interval to pass (default is three hours) to see if the location begins showing data.

If steps 1-2 are not successful, please submit a support request at Cutsforth.com/Support.

What does the  symbol on the brush location icon mean?

The  symbol indicates that attention is needed on that brush location, though it can mean a number of different things, from an abnormal brush length reading to a sensor not being connected to the BCM System. Clicking on the brush location icon can yield some information about this alert in some cases, but for the most detailed information, you can export the system logs (see section 13.2). If the alert is associated with a condition that is no longer present, pressing the "Clear Brush Length Warnings" button on the brush details screen will clear this alert.

18. Glossary

antenna	A device, typically mounted inside the exciter enclosure, which helps facilitate wireless communications between the Brush Condition Monitoring System and the Brush Health Sensors.
antenna placement mode	An optional mode included in the Brush Condition Monitoring System which displays the wireless signal strength of each sensor in or order to assist in successful placement of the antenna.
attenuation	The reduction of the amplitude of a signal due to excessive cable length.
auxiliary display	An optional, secondary enclosure of the Brush Condition Monitoring System which consists of a fully-functioning duplicate display of the primary controller.
AWG	American Wire Gauge
Brush Condition Monitoring System	A Cutsforth EASYchange® monitoring system that performs automated measurements and brush health analytics that allow plant operators to improve the efficiency of technicians' daily and weekly tasks by dispatching them to the collector when maintenance is actually needed.
Brush Health Sensor (BHS)	A wireless sensor integrated into the brush spring which communicates with the Brush Condition Monitoring System.
DCS	Distributed Control System
LOTO	Lockout/Tagout
Modbus RTU	Modbus Remote Terminal Unit
Modbus TCP	Modbus Transmission Control Protocol
primary controller	The main enclosure of the Brush Condition Monitoring System, which contains the computer and power supply as well as the main touchscreen interface.