

## Installation Planning Guide EZDP-2090 Rev L Generator Field Monitoring



## Table of Contents

1. About Cutsforth .....	3
1.1. Cutsforth Products .....	3
1.2. Cutsforth Field Services .....	3
1.3. Cutsforth Automation and Control Services .....	3
2. Legal Information .....	4
2.1. Limited Warranty .....	4
2.2. Copyright .....	5
2.3. Patents .....	5
3. Safety Information .....	6
3.1. Safety Information [English] .....	6
3.1.1. Safety Conventions .....	6
3.1.2. General Safety Instructions .....	6
3.2. Consignes de Sécurité [Français] .....	8
3.2.1. Conventions de Sécurité .....	8
3.2.2. Consignes de Sécurité Générales .....	8
4. Installation Planning for the Cutsforth Generator Field Monitoring System .....	10
5. Installation Strategies .....	11
5.1. Cabling Requirements .....	11
5.2. Positioning the Cutsforth Shaft Grounding and Contact Assemblies .....	12
5.3. Determining a Ground Conductor Termination Location .....	13
5.4. Identifying the Rotor Flux Signal Acquisition Point .....	13
5.5. Determining the Need for Rotor Flux Keyphasor Input .....	13
5.6. Identifying an Accessible and Safe Monitoring System Mounting Location .....	13
5.7. Mounting the Generator Field Monitoring System and Power Supply Enclosure .....	14
5.8. Power Requirements .....	14
5.9. Conduit and Strut Channel Recommendations .....	15
5.9.1. Recommended Strut Rack Design .....	15
6. Diagrams .....	16
6.1. Conduit Layout .....	16
6.2. Optional Shaft Contact Assembly Configuration .....	19
6.3. Enclosure Specifications .....	20
6.3.1. Generator Field Monitoring System Enclosure .....	20
6.3.2. Power Supply Enclosure .....	21
7. Integration and Infrastructure .....	22
8. Responsibilities .....	23
8.1. Planning Phase .....	23
8.2. Preparation for Service Phase .....	23
8.3. Cutsforth Service Phase – Cutsforth Technicians Onsite .....	24
8.4. InsightCM Phase .....	24
9. Glossary .....	25

# 1. About Cutsforth

Cutsforth specializes in developing innovative new technologies and services to support the power generation industry. Cutsforth's patented EASYchange® brush holder design, online truing service, InsightCM™ condition monitoring software, and patented shaft grounding and monitoring systems have been installed across the globe in generators of all sizes and in nearly every industry application, including nuclear, natural gas, coal, wind, and hydroelectric.

Cutsforth's knowledge and commitment to excellence drives our innovative solutions for the changing needs of the power industry. Whether it is a quick response to a critical situation or a new way of solving an old problem, our commitment to quality ensures that our customers receive best-in-class products and services—Cutsforth is the Power of Innovation.

Cutsforth started back in 1991 as a small company focused primarily on making replacement brush holders for generators and exciters. Today, after 30+ years in business, Cutsforth's experience and innovative designs have brought its best-in-class excitation brush holder and shaft grounding replacements and collector ring services to some of the world's largest power companies.

## 1.1. Cutsforth Products

- [EASYchange® Removable Brush Holders](#)
- [EASYchange® Brush Condition Monitoring](#)
- [Cutsforth Shaft Grounding Systems](#)
- [Rotor Flux Monitoring](#)
- [Electro-Magnetic Interference Monitoring](#)
- [InsightCM™ Condition Monitoring Software](#)

## 1.2. Cutsforth Field Services

Cutsforth provides comprehensive product installations for all product offerings as well as on-site training after the installation. We work efficiently during your outage to ensure a smooth upgrade to our innovative solutions such as Product Installations, Online Collector Ring and Commutator Truing, Spiral Groove Restoration, and Consulting and Emergency Services.

## 1.3. Cutsforth Automation and Control Services

Cutsforth provides comprehensive Automation and Control services which include data historian integration, InsightCM™ integration, DCS logic, engineered drawings and much more. This further complements our turnkey monitoring system installations.

## 2. Legal Information

### 2.1. Limited Warranty

This document is provided 'as is' and is subject to being changed, without notice, in future editions. Cutsforth reviews this document carefully for technical accuracy; however, CUTSFORTH MAKES NO EXPRESS OR IMPLIED WARRANTY AS TO THE ACCURACY OF THE INFORMATION WITHIN THIS MANUAL AS IT RELATES TO SPECIFIC INSTALLATION. THE CUSTOMER IS RESPONSIBLE FOR VERIFYING INSTALLATION AND OPERATING CONDITIONS AT EACH INSTALLATION LOCATION AND FOR EACH GENERATOR TYPE. Cutsforth warrants that its hardware products will be free of defects in materials and workmanship that cause the product to fail to substantially conform to the applicable Cutsforth published specifications for one (1) year from the date of invoice.

For a period of ninety (90) days from the date of invoice, Cutsforth warrants that (i) its software products will perform substantially in accordance with the applicable documentation provided with the software, and (ii) the software media will be free from defects in materials and workmanship. If Cutsforth receives notice of a defect or non-conformance during the applicable warranty period, Cutsforth will, in its discretion: (i) repair or replace the affected product, or (ii) refund the fees paid for the affected product. Repaired or replaced hardware will be warranted for the remainder of the original warranty period or ninety (90) days, whichever is longer. If Cutsforth elects to repair or replace the product, Cutsforth may use new or refurbished parts or products that are equivalent to new in performance and reliability and are at least functionally equivalent to the original part or product. You must obtain an RMA number from Cutsforth before returning any product to Cutsforth. Cutsforth reserves the right to charge a fee for examining and testing hardware not covered by the Limited Warranty.

This Limited Warranty does not apply if the defect of the product resulted from improper or inadequate maintenance, installation, repair, or calibration performed by a party other than Cutsforth; unauthorized modification; improper environment; use of an improper hardware or software key; improper use or operation outside of the specification for the product; improper voltages; accident, abuse, or neglect; or a hazard such as lightning, flood, or other act of nature.

THE REMEDIES SET FORTH ABOVE ARE EXCLUSIVE AND THE CUSTOMER'S SOLE REMEDIES, AND SHALL APPLY EVEN IF SUCH REMEDIES FAIL OF THEIR ESSENTIAL PURPOSE.

WARNING REGARDING USE OF CUTSFORTH SHAFT MONITORING EQUIPMENT: CUSTOMER IS ULTIMATELY RESPONSIBLE FOR VERIFYING AND VALIDATING THE SUITABILITY AND RELIABILITY OF THE PRODUCTS WHENEVER THE PRODUCTS ARE INCORPORATED IN THEIR SYSTEM OR APPLICATION, INCLUDING THE APPROPRIATE DESIGN, PROCESS, AND SAFETY LEVEL OF SUCH SYSTEM OR APPLICATION. PRODUCTS ARE NOT DESIGNED, MANUFACTURED, OR TESTED FOR USE IN LIFE OR SAFETY CRITICAL SYSTEMS, OR ANY OTHER APPLICATION IN WHICH THE FAILURE OF THE PRODUCT OR SERVICE COULD LEAD TO DEATH, PERSONAL INJURY, SEVERE PROPERTY DAMAGE OR ENVIRONMENTAL HARM (COLLECTIVELY, "HIGH-RISK USES"). FURTHER, PRUDENT STEPS MUST BE TAKEN TO PROTECT AGAINST FAILURES, INCLUDING PROVIDING BACK-UP AND SHUT-DOWN MECHANISMS. CUTSFORTH EXPRESSLY DISCLAIMS ANY EXPRESS OR IMPLIED WARRANTY OF FITNESS OF THE PRODUCTS OR SERVICES FOR HIGH-RISK USES.

CUTSFORTH DOES NOT WARRANT, GUARANTEE, OR MAKE ANY REPRESENTATIONS REGARDING THE USE OF OR THE RESULTS OF THE USE OF THE PRODUCTS IN TERMS OF CORRECTNESS, ACCURACY, RELIABILITY, OR OTHERWISE. CUTSFORTH DOES NOT WARRANT THAT THE OPERATION OF THE PRODUCTS WILL BE UNINTERRUPTED OR ERROR FREE. INCIDENTAL AND CONSEQUENTIAL DAMAGES, INCLUDING LOSS OF USE, ARE SPECIFICALLY EXCLUDED FROM THIS WARRANTY; THE MAXIMUM VALUE OF A WARRANTY CLAIM CANNOT EXCEED THE ORIGINAL VALUE OF THE ASSEMBLY OR COMPONENT.

## 2.2. Copyright

Under copyright law, this publication may not be reproduced or transmitted in any form, electronic or mechanical, including photocopying, recording, storing in an information retrieval system, or translating, in whole or in part, without the prior written consent of Cutsforth. Cutsforth respects the intellectual property of others, and we ask our users to do the same. Cutsforth software is protected by copyright and other intellectual property laws. Cutsforth software is only licensed to be run on the intended hardware for which it was purchased. Reproduction of software or written materials is prohibited unless Customer has obtained a license for that express purpose.

## 2.3. Patents

Please send patent information requests to [patents@cutsforth.com](mailto:patents@cutsforth.com).

## 3. Safety Information

### 3.1. Safety Information [English]

Following is important safety information. For safe installation and operation of this equipment, be sure to read and understand all cautions and warnings.

#### 3.1.1. Safety Conventions



##### NOTE:

Additional information.



##### ELECTRICAL DANGER

Indicates an action or specific equipment area that can result in personal injury or death from an electrical hazard if proper precautions are not taken.



##### CAUTION

Indicates a hazardous situation that, if not avoided, could result in minor or moderate injury or equipment damage.



##### WARNING

Indicates a hazardous situation that, if not avoided, could result in death or serious injury.



##### ROTATING PART CAUTION

Indicates possible injury from rotating parts.



##### DANGER

Indicates a hazardous situation that, if not avoided, will result in death or serious injury.

#### 3.1.2. General Safety Instructions



##### ELECTRICAL DANGER

Only qualified personnel who recognize shock hazards and are familiar with the safety precautions required to avoid injury should work with Cutsforth products. Among the many considerations are the following:

- Avoid contact with energized circuits.
- Avoid contact with rotating parts.
- Never install any component that appears not to be functioning in a normal manner.
- Always ensure proper installation of the holder assembly and shaft grounding rope.



### ELECTRICAL DANGER

Before working on the generator, de-energize, lock out, and tag out all power sources to the generator, shaft, and accessory devices. Electric shock and death may result due to failure to heed this warning.



### ROTATING PART CAUTION

High-voltage and rotating parts can cause serious or fatal injury. Installation, operation, and maintenance of this product must be performed only by qualified personnel, in accordance with all applicable safety regulations and guidelines.



### WARNING

Cutsforth recommends that workers do not change Shaft Contact Assembly (SCA) meter ropes while the generator is energized and/or operational. It is recommended that meter ropes be inspected and if necessary, changed during outages when the generator has been secured. Since the SCA is generally installed in relatively close proximity to the collector/brush gear (energized equipment) and or other rotating hazards in this area of the generator, it may pose a risk to workers that may include but are not limited to the following:

- Risk of entanglement or rotational injury attempting to remove/insert a meter rope.
- Risk of electrical shock.
- Risk of creating a short circuit between energized parts and ground.

These conditions and limitations are to be carefully considered at the time of installation. It is recommended that procedures and policies be implemented by the end user so as to realize the full function of the monitoring system but avoid potential hazards. These conditions generally do not apply to the Shaft Grounding Assembly (SGA) equipment installation.

## 3.2. Consignes de Sécurité [Français]

Les informations qui suivent sont essentielles afin d'assurer la sécurité de l'utilisateur lors de l'installation et de l'opération de l'équipement. Assurez-vous de bien lire et de comprendre tous les avertissements et mises en garde qui suivent.

### 3.2.1. Conventions de Sécurité

 **NOTE:**  
Informations supplémentaires.

 **RISQUES DE CHOC ÉLECTRIQUE**  
Indique que l'action ou la partie de l'équipement concernée peut mener à des blessures par électrisation ou à la mort par électrocution si les précautions adéquates ne sont pas prises.

 **MISE EN GARDE**  
Indique la présence d'une situation dangereuse qui, si elle n'est pas évitée, pourrait mener à des blessures mineures à modérées ou à des dommages matériels.

 **AVERTISSEMENT**  
Indique la présence d'une situation dangereuse qui, si elle n'est pas évitée, pourrait mener à des blessures sévères ou à la mort.

 **MISE EN GARDE : PIÈCE ROTATIVE**  
Indique la présence de pièces d'équipement rotatives pouvant causer des blessures.

 **DANGER**  
Indique la présence d'une situation dangereuse qui, si elle n'est pas évitée, pourrait mener à des blessures sévères ou à la mort.

### 3.2.2. Consignes de Sécurité Générales

 **RISQUES DE CHOC ÉLECTRIQUE**

L'utilisation des produits Cutsforth n'est recommandée qu'aux professionnels qualifiés qui savent comment reconnaître la présence de risques de choc électrique ainsi que les consignes de sécurité à suivre pour éviter les blessures liées à ces risques. Lesdites consignes de sécurité incluent, sans s'y limiter :

- Éviter tout contact avec des circuits alimentés;
- Éviter tout contact avec des pièces d'équipement rotatives;
- Ne jamais installer de composante ne paraissant pas fonctionner normalement;
- Toujours s'assurer que la structure de soutien et le câble de terre de l'arbre de la génératrice sont correctement installés.



## RISQUES DE CHOC ÉLECTRIQUE

Avant de travailler sur la génératrice, désalimentez, cadenassez et étiquetez toutes les sources d'énergies liées à la génératrice, à l'arbre et aux appareils accessoires. L'opérateur s'expose à des risques de chocs électriques pouvant causer la mort s'il ne tient pas compte de cet avertissement.



## MISE EN GARDE : PIÈCE ROTATIVE

Les pièces d'équipement rotatives et sous haute tension peuvent causer des blessures sévères ou fatales. L'installation, l'opération et la manutention de ce produit ne doivent être faites que par des professionnels qualifiés et en respectant toutes les règles et consignes de sécurité applicables.



## AVERTISSEMENT

Cutsforth recommande aux travailleurs de ne pas changer les câbles de mesure de l'ensemble de contact avec l'arbre (ECA) lorsque le générateur est alimenté et/ou opérationnel. Il est recommandé d'inspecter les câbles de mesure et, si nécessaire, de les changer pendant les arrêts, lorsque le générateur a été sécurisé. Étant donné que l'ECA est généralement installé relativement près du collecteur et des frotteurs (lesquels sont sous tension) ainsi que d'autres composantes rotatives, l'utilisation ou la manutention de l'ECA peut présenter des risques pour les travailleurs, qui peuvent inclure les éléments suivants, sans s'y limiter :

- Risques d'être blessé par des composantes rotatives ou d'être coincé dans celles-ci en tentant d'enlever ou d'insérer un câble de mesure;
- Risques de choc électrique;
- Risques de créer un court-circuit entre des composantes alimentées et la mise à la terre.

Ces conditions et contraintes doivent être attentivement prises en considération lors de l'installation de l'ECA. Il est recommandé que l'utilisateur final implémente des protocoles et des politiques visant à s'assurer que le système de surveillance puisse être utilisé en évitant les risques potentiels liés à celui-ci sans compromettre son efficacité. Ces conditions ne s'appliquent généralement pas lors de l'installation de l'ensemble de mise à la terre de l'arbre (EMTA).

## 4. Installation Planning for the Cutsforth Generator Field Monitoring System

This manual is a guide for planning the installation of the Cutsforth Generator Field Monitoring System (GFM). Review the documentation for the original or OEM shaft grounding system for planning the removal of that system.



This manual does not cover all details or variations in equipment, nor does it consider every possible contingency for installation, operation, or maintenance. If you have questions or concerns that are not addressed in this manual, contact Cutsforth Engineering Support.

## 5. Installation Strategies

Determine the best component locations for your installation by applying the following strategies.

### 5.1. Cabling Requirements

Please review this list of best installation practices to help ensure maximum effectiveness of your Cutsforth Generator Field Monitoring System:

- Avoid sharp bends and coils in the grounding wire whenever possible. Bending or coiling the conductor can create induction back on itself and lessen the quality of the ground.

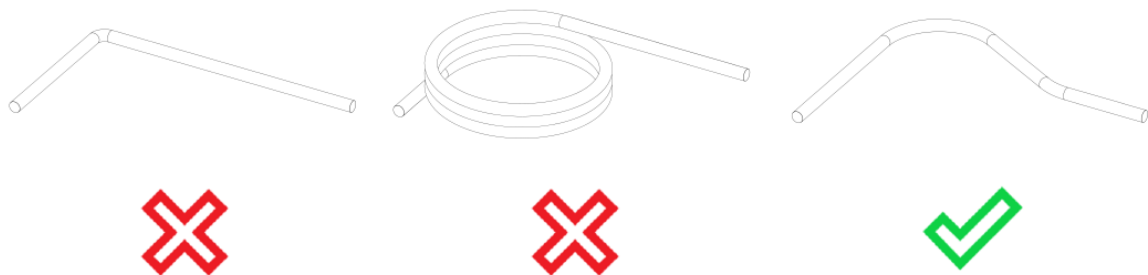

- Route the grounding conductor and signal cable according to the shortest possible paths.
  - The total ground conductor length from the Shaft Grounding Assembly (SGA) to the unit case ground termination point shall not exceed 5 ft (1.5 m).
  - The total signal cable length from the SGA to the Cutsforth Shaft Ground Monitoring System shall not exceed 30 ft (9 m). Deviations require sign-off by Cutsforth Engineering.
- The [optional] Shaft Contact Assembly (SCA) signal cable shall not exceed 80 ft (24.25 m). Deviations require sign-off by Cutsforth Engineering.
- The rotor flux signal cable run shall not exceed 100 ft (30.5 m) in total run length.

## 5.2. Positioning the Cutsforth Shaft Grounding and Contact Assemblies

The Cutsforth Shaft Grounding and Contact Assemblies both have a minimum/maximum operating temperature range of -15°C (5°F) to 150°C (300°F).

The Cutsforth Shaft Grounding Assembly is installed on the same portion of exposed shaft as the previous grounding equipment.

The Cutsforth Shaft Contact Assembly is installed on an exposed portion of the shaft at the exciter-end of the generator at a location at which a secondary shaft voltage measurement is desired.

Both the Shaft Grounding Assembly and Shaft Contact Assembly must be installed on the “uphill” side of the shaft rotation. Installing on this side of the shaft ensures that the rope does not bunch up or bind up inside the rope guide. The following illustration shows the correct orientation on the left.

Verify that there is adequate spacing on all dimensions of the SGA and/or SCA assemblies including the support arm and mounting point. Consider both the hot and cold operational conditions, and account for thermal expansion when installing in narrow clearance locations. Factors such as generator type may affect the clearances needed to account for thermal expansion.

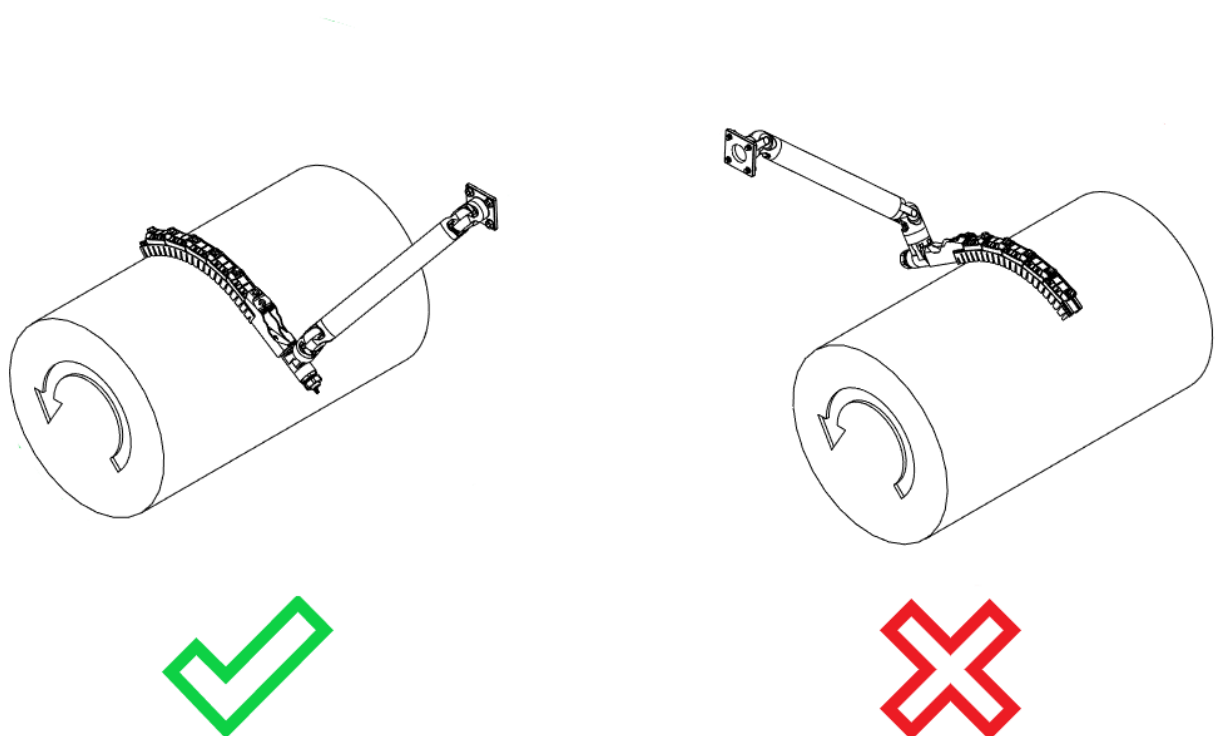

### 5.3. Determining a Ground Conductor Termination Location

The goal when choosing a grounding location is to electrically bond the shaft to the unit case. The unit case is defined by the lower half of either the turbine case, generator case, or coupler case near the Shaft Grounding Assembly to which the shaft can be grounded. Cutsforth suggests drilling and tapping into the lower half of the unit case to create a grounding location close to the Shaft Grounding Assembly.

The location at which the ground wire will terminate should have all paint removed and should be free of all contaminants in order to create a smooth, conductive surface. Structural steel and station ground are examples of unacceptable grounding locations. It is important to note that it is not necessary for the ground conductor to be grounded to an existing generator grounding pad.

### 5.4. Identifying the Rotor Flux Signal Acquisition Point

The presence of a rotor flux probe on the subject generator should be validated in advance of equipment installation, and its location should be verified. The rotor flux signal is typically acquired at either the rotor flux probe itself or on a set of terminals inside of an electrical cabinet nearby. The Generator Field Monitoring System should then be mounted in a location that satisfies all cable length requirements.

### 5.5. Determining the Need for Rotor Flux Keyphasor Input

A keyphasor input is required for any unit that is salient pole or has more than two (2) poles. The rotor flux module inside of the Cutsforth monitoring system has available connection points to accommodate the keyphasor input. Keyphasor input signals must have one pulse per shaft rotation. Signal must be from -24 V to 24 V.

### 5.6. Identifying an Accessible and Safe Monitoring System Mounting Location

The Generator Field Monitoring System has a maximum operating temperature range of -15°C (5°F) to 70°C (158°F).

Avoid mounting the enclosure in areas that approach or exceed this temperature on a regular basis. If possible, avoid mounting the monitoring system in a location that experiences direct sunlight for extended periods of time throughout the day. If sunshine exposure is unavoidable, inquire with Cutsforth about installation of a sun shield.

The monitoring system should be installed in such a way that does not complicate generator disassembly during outages.

The monitoring system should be accessible to personnel for servicing as needed, and for troubleshooting using the Shaft Grounding Assembly test points. However, system surveillance and performance feedback is not viewable at the monitoring system panel.

The monitoring system should be mounted in a location that does not experience excessive vibrations. Mounting directly to rotating equipment, such as a generator, or other structures with known vibrations,

is not recommended. All cabling should be strain-relieved near input connectors. Take care to not directionally bias cable connectors when applying strain relief.

## 5.7. Mounting the Generator Field Monitoring System and Power Supply Enclosure

The Generator Field Monitoring System and Power Supply enclosures are commonly mounted using strut channel provided by the electrical contractor. Cutsforth recommends the use of a floor-mounted strut channel structure, as it is typically less suspect to excessive vibration. If a wall-mounted structure is necessary, Cutsforth recommends vibration isolation mounting means be employed. The image below is a suitable example configuration.



## 5.8. Power Requirements

Power Requirement	Value
Voltage	85-264 VAC
Recommended breaker size	20 A
Recommended power cabling wire gauge	12 AWG
Actual operational current draw	~ 0.5 A at 120 VAC

## 5.9. Conduit and Strut Channel Recommendations

Component	Standard Recommendation	Recommendation for High-Corrosion Environments
Conduit type	Galvanized rigid metal conduit (RMC)	Rigid Aluminum Conduit (RAC)
Conduit fittings type	Malleable	Aluminum
Strut channel type	Hot dipped galvanized, back-to-back	316 Stainless steel
Mounting hardware	316 Stainless steel	316 Stainless steel
Liquid flexible metallic conduit	Type HCX	Type HCX

Cutsforth recommends that a duct seal be used to seal the inside of any conduit entering the Cutsforth monitoring system enclosure(s). The duct seal should be non-permanent in nature to accommodate future equipment or cable maintenance.

### 5.9.1. Recommended Strut Rack Design

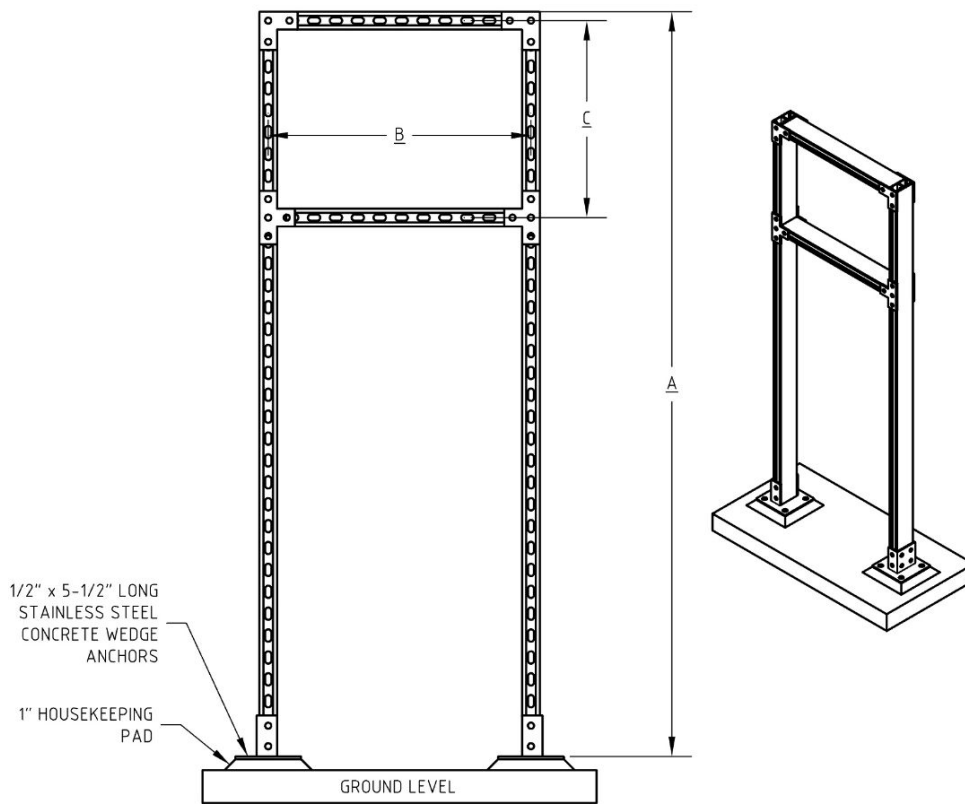

A (in (cm))	B (in (cm))	C (in (cm))
68 (173)	24 (61)	Refer to enclosure mounting feet dimensions

## 6. Diagrams

### 6.1. Conduit Layout

Color on Diagram (next page)	Conduit Run Description	Conduit Trade Size	Max Run Length	Wire Description	Purpose	Wire Supplied By	Conduit Supplied By
Red	Shaft Grounding Assembly to Junction Box	N/A	4 ft (1.2 m)	Twisted pair, individually shielded, high temp, 18 AWG + 8 AWG Ground	Signals and ground from SGA to Junction Box	Cutsforth	N/A
Black	Junction Box to unit case ground	N/A	1 ft (0.3 m)	Single conductor, 8 AWG, high temp	Ground from Junction Box to unit case ground	Cutsforth	N/A
Purple	Junction Box to monitoring system	3/4 in. (2 cm)	27 ft (8.2 m)	Two high-voltage, CAT6a Ethernet cables	Signals from Junction Box to monitoring system	Cutsforth	Plant Electrical Contractor
Green	Monitoring System to case ground	N/A	20 ft (6.1 m)	Single conductor, 12 AWG	Enclosure case ground	Cutsforth	N/A
Blue	Flux Probe to monitoring system	3/4 in. (2 cm)	100 ft (30.5 m)	Single twisted-pair, shielded, with drain, 18 AWG	Signal from rotor flux probe	Plant Electrical Contractor	Plant Electrical Contractor
Orange	Data output to control room	3/4 in. (2 cm)	N/A	CAT6a, shielded, cable tray rated, Ethernet recommended	Monitoring output to plant's control room	Plant Electrical Contractor	Plant Electrical Contractor
Yellow (optional)	Shaft Contact Assembly to monitoring system	3/4 in. (2 cm)	80 ft (24.4 m)	High-voltage, CAT6a Ethernet cable	Signals from SCA to monitoring system	Cutsforth	Plant Electrical Contractor
Gray	Power Supply Enclosure to monitoring system	3/4 in. (2 cm)	25 ft (7.6 m)	Single twisted-pair, shielded, 16 AWG	DC power for monitoring system	Cutsforth	Plant Electrical Contractor

Color on Diagram (next page)	Conduit Run Description	Conduit Trade Size	Max Run Length	Wire Description	Purpose	Wire Supplied By	Conduit Supplied By
Aqua	Dedicated 120V AC power to monitoring system	3/4 in. (2 cm)	N/A	AC: 85-264V AC, 47-440 Hz, 10 W or DC: 20-32 V DC, 10W  20 A Circuit	AC power for monitoring system power supply	Plant Electrical Contractor	Plant Electrical Contractor
Magenta (if required - see <a href="#">Determining the Need for Rotor Flux Keyphasor Input</a> (page 13))	Keyphasor to monitoring system	3/4 in. (2 cm)	N/A	Single twisted-pair, shielded, with drain, 18 AWG	Signal from keyphasor (-24 V to 24 V)	Plant Electrical Contractor	Plant Electrical Contractor

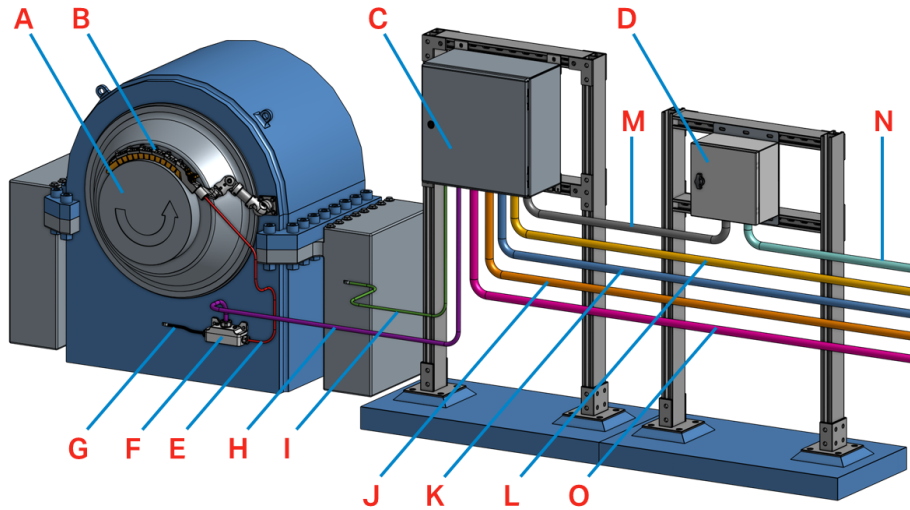

Part	Name	Part	Name
<b>A</b>	Shaft Rotation Direction	<b>H</b>	Purple: 3/4 in. (2 cm) conduit from Junction Box to monitoring system
<b>B</b>	Shaft Grounding Assembly	<b>I</b>	Green: 12 AWG wire for enclosure case ground
<b>C</b>	Cutsforth Generator Field Monitoring System	<b>J</b>	Orange: 3/4 in. (2 cm) conduit for data output to control room
<b>D</b>	Power Supply Enclosure	<b>K</b>	Blue: 3/4 in. (2 cm) conduit from rotor flux probe to monitoring system
<b>E</b>	Red: Signal and ground cables from SGA to Junction Box	<b>L</b>	(optional) Yellow: 3/4 in. (2 cm) conduit from SCA to monitoring system
<b>F</b>	Junction Box	<b>M</b>	Gray: 3/4 in. (2 cm) conduit from Power Supply Enclosure to monitoring system
<b>G</b>	Black: 8 AWG from Junction Box to unit case ground	<b>N</b>	Aqua: 3/4 in. (2 cm) conduit for plant power input
		<b>O</b>	(If required - see <a href="#">Determining the Need for Rotor Flux Keyphasor Input (page 13)</a> ) Magenta: 3/4 in. (2 cm) conduit for keyphasor input

## 6.2. Optional Shaft Contact Assembly Configuration

The following figure represents a typical layout. Individual installations may vary.

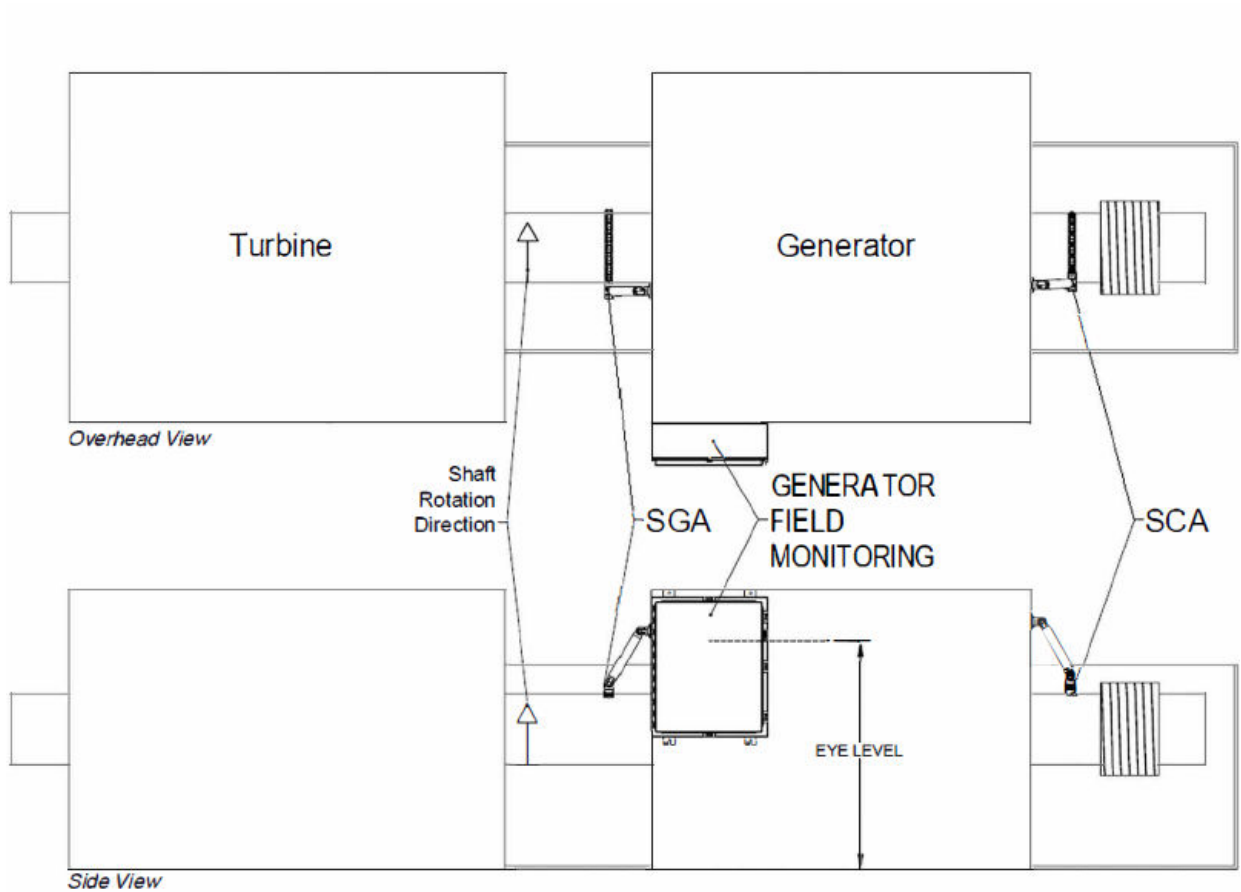

## 6.3. Enclosure Specifications

### 6.3.1. Generator Field Monitoring System Enclosure

Catalog Number	Dimensions (in. (mm))	Stainless Steel Type
CSD16168SS6-MODS	16.0 (406) x 16.0 (406) x 8.0 (203)	316

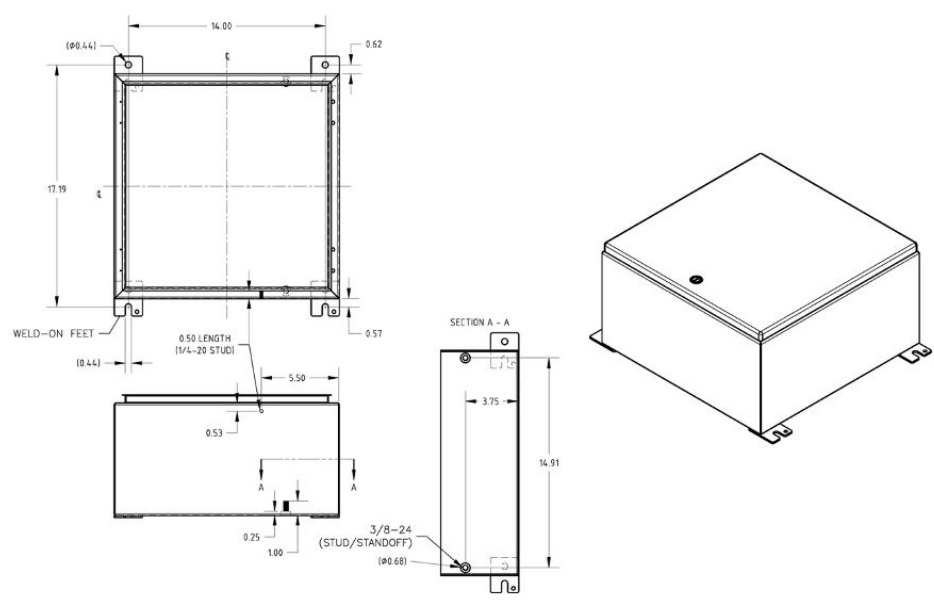

#### Specifications:

- |   |   |
|---|---|
| <ul style="list-style-type: none"> <li>UL 508A Listed; Type 3R, 4, 4X, 12; File No. E61997</li> <li>cUL Listed per CSA C22.2 No 94; Type 3R, 4, 4X, 12; File No. E61997</li> <li>NEMA/EEMAC Type 3R, 4, 4X, 12, 13</li> <li>CSA File No. 42186; Type 4, 4X, 12</li> </ul> | <ul style="list-style-type: none"> <li>VDE IP66</li> <li>IEC 60529, IP66</li> <li>Meets NEMA Type 3RX requirements</li> </ul> |
|---|---|

#### EXMC-002: Optional sunshield for outdoor installations

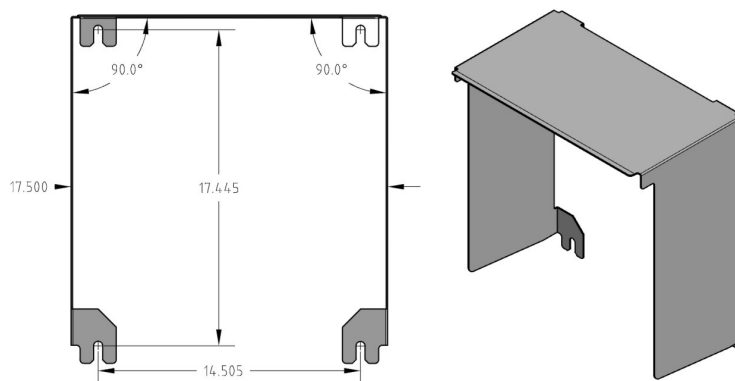

### 6.3.2. Power Supply Enclosure

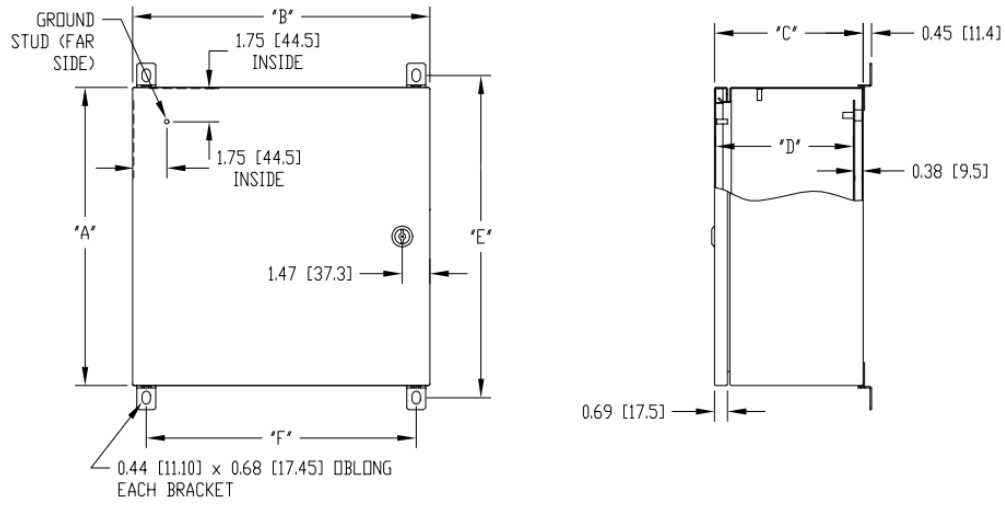

Catalog Number	A (in/cm)	B (in/cm)	C (in/cm)	D (in/cm)	E (in/cm)	F (in/cm)
SNB-3740	9.84/25.00	7.87/20.00	5.91/15.00	5.33/13.54	11.12/28.24	6.42/16.30

## 7. Integration and Infrastructure

The Cutsforth Generator Field Monitoring System is designed to be integrated into Cutsforth's InsightCM™ software. Find out more about InsightCM™ [here](#). Specific server requirements can be found [here](#).

The plant must provide a PC or Server for InsightCM™ meeting the requirements listed at the above link. Cutsforth is not responsible for the configuration of server-side deployment. Ensure the plant's InsightCM™ server is set up and ready for communication to field equipment in advance of system commissioning by Cutsforth.

## 8. Responsibilities

The following tables summarize the responsibilities of Cutsforth and the Plant during the three project phases:

### 8.1. Planning Phase

Task	Cutsforth	Plant
Review this planning guide and share it with key plant personnel involved in the project.		X
Determine the enclosure mounting positions and conduit routes customized to the generator and ensure that they are within system guidelines.		X
Select an Electrical Contractor and coordinate.		X

### 8.2. Preparation for Service Phase



The responsibilities listed in the following table are critical to technician safety and proper installation of the Cutsforth equipment. Failure to comply may result in significant delays and additional charges.

Task	Cutsforth	Plant
Determine the enclosure mounting positions and conduit routes customized to the generator and ensure it is within system requirements.		X
Mount the Monitoring System and Power Supply enclosures with supporting strut channel rails and install required conduit, complete with pull strings.		X
LOTO the following components: Main excitation system, ground detection system, and turning gear. LOTO needs to be in place prior to arrival of Cutsforth technicians.		X
Provide 120V GFI protected power.		X
Provide adequate working access to the installation site including scaffolding. Scaffolding must be erected prior to arrival of Cutsforth technicians.		X
Ensure that the shaft is off turn gear and stationary.		X
Ensure that the shaft is fully coupled for installation.		X
Ensure that the bearing caps immediately adjacent to the shaft grounding area are in place.		X

### 8.3. Cutsforth Service Phase – Cutsforth Technicians On-site

Task	Cutsforth	Plant
Provide shaft growth value at the grounding location to a Cutsforth technician.		X
Indicate shaft rotation direction to a Cutsforth technician.		X
Install the Cutsforth shaft assembly.	X	
Run wiring in plant-completed conduit raceways.	X	
Identify the main grounding termination point on the unit case.	X	
Make system wiring terminations.	X	
Make grounding termination to the unit case.	X	
Perform system testing and commissioning.	X	
Control room/IT support for testing data outputs of the monitoring system.	X	X

### 8.4. InsightCM Phase

Task	Cutsforth	Plant
Review <a href="#">InsightCM™ Server Requirements</a> .		X
Procure a server for InsightCM™ (if not done already).		X
Verify that server meets requirements before installing software.		X
Verify server prerequisites are checked (IIS Role).		X
Install InsightCM™ on the server.		X
Install the <a href="#">Google Chrome</a> browser on the server.		X
If using a Windows 10 server, inquire with Cutsforth about the NI RAD Utility. Otherwise, skip this step.		X
Power on the Cutsforth monitoring equipment.	X	
Configure IP addresses for the Cutsforth monitoring equipment from the server.		X
Connect the Cutsforth device to the server using an Ethernet or fiber cable.		X
Create the device's asset tree in InsightCM™ and validate.		X
Create the device in InsightCM™ using the configured IP addresses.		X
Configure desired alarm settings, if desired alarms are known.		X
Using InsightCM™, establish a connection to the field device.		X
Confirm data is being collected, can be viewed in InsightCM™, and is accurate. This task would likely be performed by Cutsforth's Software and Electronics team after the service portion of the installation has been completed.	X	X

Cutsforth offers all of the tasks listed in the InsightCM™ Phase as a service. Please inquire if you are interested in having Cutsforth perform these tasks.

## 9. Glossary

attenuation	The reduction of the amplitude of a signal due to excessive cable length.
AWG	American Wire Gauge
circular connector	A cabling connector attached to the Cutsforth Shaft Grounding and Shaft Contact Assemblies that allows for a secure, sealed, threaded connection.
Generator Field Monitoring System	A Cutsforth product which monitors shaft voltages, shaft currents, and rotor flux signals and provides real-time data and analytics through Cutsforth's InsightCM™ software.
ground conductor	8 AWG, green ground conductor that carries the shaft current to the unit case ground location.
ground current	The electrical current between the shaft and the unit case ground through the ground conductor.
ground rope	The left rope in the Shaft Grounding Assembly, which provides the primary path to unit case ground through the 8AWG ground conductor.
impedance	The resistance to change in the current of a circuit.
LOTO	Lockout/Tagout
meter rope	The right rope in the Shaft Grounding Assembly which provides a shaft contact point at which shaft voltage readings are taken.
power supply enclosure	A Cutsforth enclosure that houses a power supply which accepts AC power from the plant and converts it to DC for use in various Cutsforth monitoring systems.
rotor flux	The magnetic fields created by the generator windings.
rotor flux probe	A sensing device which measures the rotor flux and provides a signal output.
Shaft Grounding Assembly (SGA)	A Cutsforth product designed to provide a best-in-class ground connection, as well as a shaft contact point at which shaft voltage can be measured.
shaft voltage	The voltage potential between the shaft and the unit case ground as measured by the metering rope.

signal cable	Shielded cable that carries the voltage signals from the SGA and the SCA to the monitoring system.
unit	The equipment monitored by the Cutsforth monitoring system.
unit case ground	The lower half of the turbine case, generator case, or coupler case near the Shaft Grounding Assembly to which the shaft can be grounded.