

CUTSFORTH

Operations Manual CED-1008 Rev K EASYchange Brush Holder System



Table of Contents

1. About Cutsforth	3
1.1. Cutsforth Products	3
1.2. Cutsforth Field Services	3
1.3. Cutsforth Automation and Control Services	3
2. Legal Information	4
2.1. Limited Warranty	4
2.2. Copyright	5
2.3. Patents	5
3. Safety Information	6
3.1. Safety Information [English]	6
3.1.1. Safety Conventions	6
3.1.2. General Safety Instructions	6
3.2. Consignes de Sécurité [Français]	7
3.2.1. Conventions de Sécurité	7
3.2.2. Consignes de Sécurité Générales	8
4. The Cutsforth Brush Holder	9
4.1. Components	9
4.2. Knowing When to Change a Brush	11
5. Replacing a Brush Holder	13
5.1. Removing a Brush Holder	14
5.2. Inspecting a Brush Holder	15
5.2.1. Online Inspections	15
5.2.2. Offline Inspections	15
5.3. Removing a Brush	16
5.4. Removing a Brush Spring	19
5.5. Installing a New Brush	19
5.5.1. Install a Brush Spring	20
5.5.2. Install a Brush	21
5.5.3. Position the Brush Shunts	24
5.6. Returning a Brush Holder to Service	25
5.6.1. Install a Brush Holder	26
5.6.2. Verify the Brush Holder Installation	27
6. Replacing a Holder Mount	29
6.1. Removing Holder Mounts	29
6.2. Installing the Holder Mounts	30
6.2.1. Install a Holder Mount Using the Height Setter	31
7. Glossary	35

1. About Cutsforth

Cutsforth specializes in developing innovative new technologies and services to support the power generation industry. Cutsforth's patented EASYchange® brush holder design, online truing service, InsightCM™ condition monitoring software, and patented shaft grounding and monitoring systems have been installed across the globe in generators of all sizes and in nearly every industry application, including nuclear, natural gas, coal, wind, and hydroelectric.

Cutsforth's knowledge and commitment to excellence drives our innovative solutions for the changing needs of the power industry. Whether it is a quick response to a critical situation or a new way of solving an old problem, our commitment to quality ensures that our customers receive best-in-class products and services—Cutsforth is the Power of Innovation.

Cutsforth started back in 1991 as a small company focused primarily on making replacement brush holders for generators and exciters. Today, after 30+ years in business, Cutsforth's experience and innovative designs have brought its best-in-class excitation brush holder and shaft grounding replacements and collector ring services to some of the world's largest power companies.

1.1. Cutsforth Products

- [EASYchange® Removable Brush Holders](#)
- [EASYchange® Brush Condition Monitoring](#)
- [Cutsforth Shaft Grounding Systems](#)
- [Rotor Flux Monitoring](#)
- [Electro-Magnetic Interference Monitoring](#)
- [InsightCM™ Condition Monitoring Software](#)

1.2. Cutsforth Field Services

Cutsforth provides comprehensive product installations for all product offerings as well as on-site training after the installation. We work efficiently during your outage to ensure a smooth upgrade to our innovative solutions such as Product Installations, Online Collector Ring and Commutator Truing, Spiral Groove Restoration, and Consulting and Emergency Services.

1.3. Cutsforth Automation and Control Services

Cutsforth provides comprehensive Automation and Control services which include data historian integration, InsightCM™ integration, DCS logic, engineered drawings and much more. This further complements our turnkey monitoring system installations.

2. Legal Information

2.1. Limited Warranty

This document is provided 'as is' and is subject to being changed, without notice, in future editions. Cutsforth reviews this document carefully for technical accuracy; however, CUTSFORTH MAKES NO EXPRESS OR IMPLIED WARRANTY AS TO THE ACCURACY OF THE INFORMATION WITHIN THIS MANUAL AS IT RELATES TO SPECIFIC INSTALLATION. THE CUSTOMER IS RESPONSIBLE FOR VERIFYING INSTALLATION AND OPERATING CONDITIONS AT EACH INSTALLATION LOCATION AND FOR EACH GENERATOR TYPE. Cutsforth warrants that its hardware products will be free of defects in materials and workmanship that cause the product to fail to substantially conform to the applicable Cutsforth published specifications for one (1) year from the date of invoice.

For a period of ninety (90) days from the date of invoice, Cutsforth warrants that (i) its software products will perform substantially in accordance with the applicable documentation provided with the software, and (ii) the software media will be free from defects in materials and workmanship. If Cutsforth receives notice of a defect or non-conformance during the applicable warranty period, Cutsforth will, in its discretion: (i) repair or replace the affected product, or (ii) refund the fees paid for the affected product. Repaired or replaced hardware will be warranted for the remainder of the original warranty period or ninety (90) days, whichever is longer. If Cutsforth elects to repair or replace the product, Cutsforth may use new or refurbished parts or products that are equivalent to new in performance and reliability and are at least functionally equivalent to the original part or product. You must obtain an RMA number from Cutsforth before returning any product to Cutsforth. Cutsforth reserves the right to charge a fee for examining and testing hardware not covered by the Limited Warranty.

This Limited Warranty does not apply if the defect of the product resulted from improper or inadequate maintenance, installation, repair, or calibration performed by a party other than Cutsforth; unauthorized modification; improper environment; use of an improper hardware or software key; improper use or operation outside of the specification for the product; improper voltages; accident, abuse, or neglect; or a hazard such as lightning, flood, or other act of nature.

THE REMEDIES SET FORTH ABOVE ARE EXCLUSIVE AND THE CUSTOMER'S SOLE REMEDIES, AND SHALL APPLY EVEN IF SUCH REMEDIES FAIL OF THEIR ESSENTIAL PURPOSE.

WARNING REGARDING USE OF CUTSFORTH SHAFT MONITORING EQUIPMENT: CUSTOMER IS ULTIMATELY RESPONSIBLE FOR VERIFYING AND VALIDATING THE SUITABILITY AND RELIABILITY OF THE PRODUCTS WHENEVER THE PRODUCTS ARE INCORPORATED IN THEIR SYSTEM OR APPLICATION, INCLUDING THE APPROPRIATE DESIGN, PROCESS, AND SAFETY LEVEL OF SUCH SYSTEM OR APPLICATION. PRODUCTS ARE NOT DESIGNED, MANUFACTURED, OR TESTED FOR USE IN LIFE OR SAFETY CRITICAL SYSTEMS, OR ANY OTHER APPLICATION IN WHICH THE FAILURE OF THE PRODUCT OR SERVICE COULD LEAD TO DEATH, PERSONAL INJURY, SEVERE PROPERTY DAMAGE OR ENVIRONMENTAL HARM (COLLECTIVELY, "HIGH-RISK USES"). FURTHER, PRUDENT STEPS MUST BE TAKEN TO PROTECT AGAINST FAILURES, INCLUDING PROVIDING BACK-UP AND SHUT-DOWN MECHANISMS. CUTSFORTH EXPRESSLY DISCLAIMS ANY EXPRESS OR IMPLIED WARRANTY OF FITNESS OF THE PRODUCTS OR SERVICES FOR HIGH-RISK USES.

CUTSFORTH DOES NOT WARRANT, GUARANTEE, OR MAKE ANY REPRESENTATIONS REGARDING THE USE OF OR THE RESULTS OF THE USE OF THE PRODUCTS IN TERMS OF CORRECTNESS, ACCURACY, RELIABILITY, OR OTHERWISE. CUTSFORTH DOES NOT WARRANT THAT THE OPERATION OF THE PRODUCTS WILL BE UNINTERRUPTED OR ERROR FREE. INCIDENTAL AND CONSEQUENTIAL DAMAGES, INCLUDING LOSS OF USE, ARE SPECIFICALLY EXCLUDED FROM THIS WARRANTY; THE MAXIMUM VALUE OF A WARRANTY CLAIM CANNOT EXCEED THE ORIGINAL VALUE OF THE ASSEMBLY OR COMPONENT.

2.2. Copyright

Under copyright law, this publication may not be reproduced or transmitted in any form, electronic or mechanical, including photocopying, recording, storing in an information retrieval system, or translating, in whole or in part, without the prior written consent of Cutsforth. Cutsforth respects the intellectual property of others, and we ask our users to do the same. Cutsforth software is protected by copyright and other intellectual property laws. Cutsforth software is only licensed to be run on the intended hardware for which it was purchased. Reproduction of software or written materials is prohibited unless Customer has obtained a license for that express purpose.

2.3. Patents

Please send patent information requests to patents@cutsforth.com.

3. Safety Information

3.1. Safety Information [English]

Following is important safety information. For safe installation and operation of this equipment, be sure to read and understand all cautions and warnings.

3.1.1. Safety Conventions



NOTE:

Additional information.



ELECTRICAL DANGER

Indicates an action or specific equipment area that can result in personal injury or death from an electrical hazard if proper precautions are not taken.



CAUTION

Indicates a hazardous situation that, if not avoided, could result in minor or moderate injury or equipment damage.



WARNING

Indicates a hazardous situation that, if not avoided, could result in death or serious injury.



ROTATING PART CAUTION

Indicates possible injury from rotating parts.



DANGER

Indicates a hazardous situation that, if not avoided, will result in death or serious injury.

3.1.2. General Safety Instructions



ELECTRICAL DANGER

Only qualified personnel who recognize shock hazards and are familiar with the safety precautions required to avoid injury should work with Cutsforth products. Among the many considerations are the following:

- Avoid contact with energized circuits.
- Avoid contact with rotating parts.
- Never install any component that appears not to be functioning in a normal manner.
- Always ensure proper installation of the holder assembly and shaft grounding rope.



ELECTRICAL DANGER

Before working on the generator, de-energize, lock out, and tag out all power sources to the generator, shaft, and accessory devices. Electric shock and death may result due to failure to heed this warning.



ROTATING PART CAUTION

High-voltage and rotating parts can cause serious or fatal injury. Installation, operation, and maintenance of this product must be performed only by qualified personnel, in accordance with all applicable safety regulations and guidelines.



WARNING

Never mix different carbon brush grades or brushes from different manufacturers on the same unit.

3.2. Consignes de Sécurité [Français]

Les informations qui suivent sont essentielles afin d'assurer la sécurité de l'utilisateur lors de l'installation et de l'opération de l'équipement. Assurez-vous de bien lire et de comprendre tous les avertissements et mises en garde qui suivent.

3.2.1. Conventions de Sécurité



NOTE:

Informations supplémentaires.



RISQUES DE CHOC ÉLECTRIQUE

Indique que l'action ou la partie de l'équipement concernée peut mener à des blessures par électrisation ou à la mort par électrocution si les précautions adéquates ne sont pas prises.



MISE EN GARDE

Indique la présence d'une situation dangereuse qui, si elle n'est pas évitée, pourrait mener à des blessures mineures à modérées ou à des dommages matériels.



AVERTISSEMENT

Indique la présence d'une situation dangereuse qui, si elle n'est pas évitée, pourrait mener à des blessures sévères ou à la mort.



MISE EN GARDE : PIÈCE ROTATIVE

Indique la présence de pièces d'équipement rotatives pouvant causer des blessures.



DANGER

Indique la présence d'une situation dangereuse qui, si elle n'est pas évitée, pourrait mener à des blessures sévères ou à la mort.

3.2.2. Consignes de Sécurité Générales



RISQUES DE CHOC ÉLECTRIQUE

L'utilisation des produits Cutsforth n'est recommandée qu'aux professionnels qualifiés qui savent comment reconnaître la présence de risques de choc électrique ainsi que les consignes de sécurité à suivre pour éviter les blessures liées à ces risques. Lesdites consignes de sécurité incluent, sans s'y limiter :

- Éviter tout contact avec des circuits alimentés;
- Éviter tout contact avec des pièces d'équipement rotatives;
- Ne jamais installer de composante ne paraissant pas fonctionner normalement;
- Toujours s'assurer que la structure de soutien et le câble de terre de l'arbre de la génératrice sont correctement installés.



RISQUES DE CHOC ÉLECTRIQUE

Avant de travailler sur la génératrice, désalimentez, cadenassez et étiquetez toutes les sources d'énergies liées à la génératrice, à l'arbre et aux appareils accessoires. L'opérateur s'expose à des risques de chocs électriques pouvant causer la mort s'il ne tient pas compte de cet avertissement.



MISE EN GARDE : PIÈCE ROTATIVE

Les pièces d'équipement rotatives et sous haute tension peuvent causer des blessures sévères ou fatales. L'installation, l'opération et la manutention de ce produit ne doivent être faites que par des professionnels qualifiés et en respectant toutes les règles et consignes de sécurité applicables.



AVERTISSEMENT

Ne jamais utiliser de frotteurs de différentes qualités ou venant de différents fabricants sur le même appareil.

4. The Cutsforth Brush Holder

This manual covers:

- Cutsforth Brush Holder components
- Knowing when to change a brush
- Removing the brush holder
- Inspecting the brush holder
- Changing the spring and brush
- Remounting the brush holder
- Removing and installing the holder mount



NOTE:

This manual does not cover all details or variations in equipment, nor does it consider every possible contingency for installation, operation, or maintenance. If you have questions or concerns that are not addressed in this manual, contact Cutsforth Engineering Support.

4.1. Components

This section displays and lists the components of the Cutsforth Brush Holder:



CAUTION

Do not adjust the 10-32 screw on the top of the holder mount. This fastener is set at the factory and does not need to be changed. Improper adjustment of this fastener on older models disables the over-center locking mechanism. The latest models cannot be improperly adjusted.

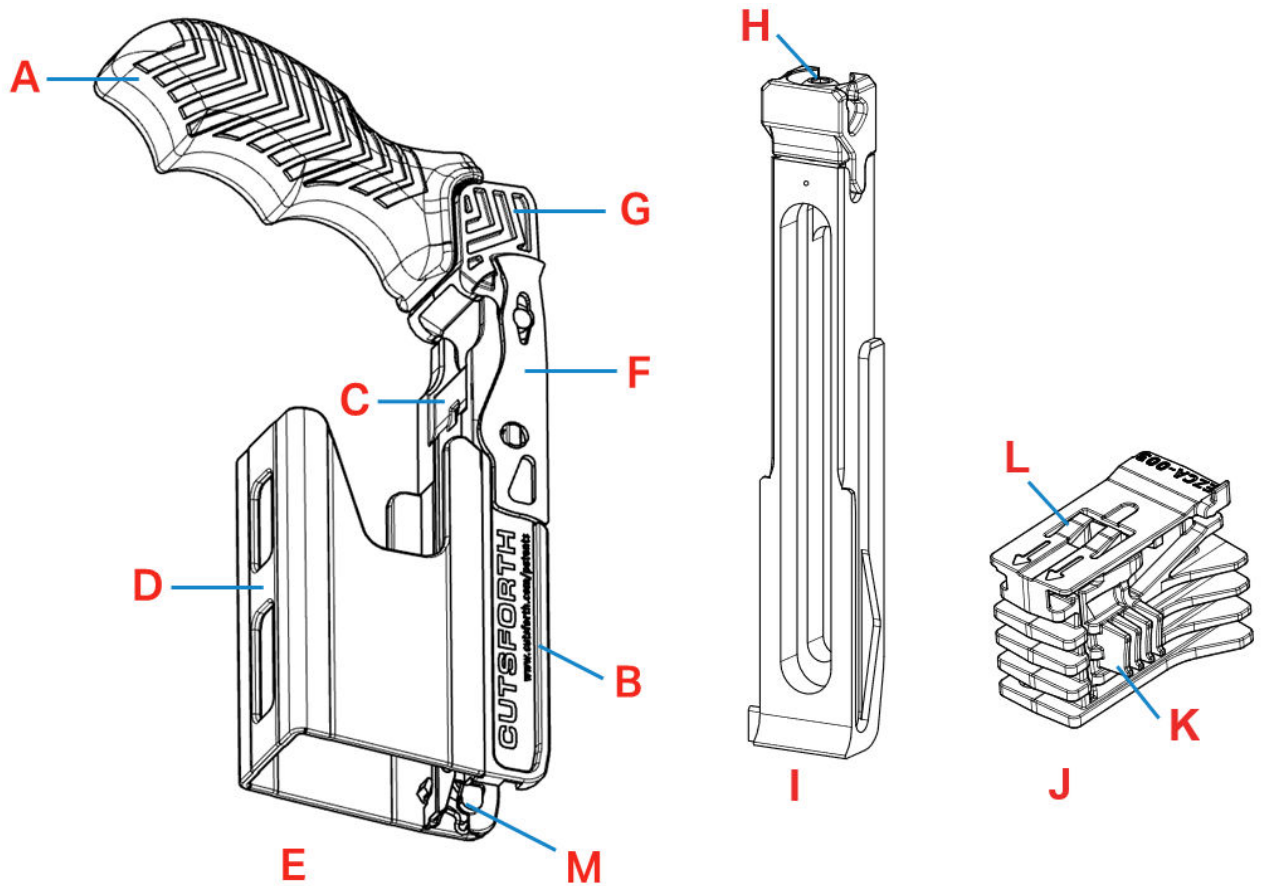

Part	Description	Part	Description
A	Handle	G	Upper beam
B	Terminal mount rib	H	10-32 screw – DO NOT ADJUST
C	Lower beam	I	Holder mount
D	Brush box	J	Brush key
E	Brush Holder	K	Release tab
F	Catch arm	L	Brush spring release fingers
		M	Brush catch

4.2. Knowing When to Change a Brush



CAUTION

New brushes contact the ring across a very small area. Therefore, a best practice is to replace a small portion of the brushes (10%-20%) first. Then ensure that the brush faces are seated at least 50% before replacing more brushes. This number may vary depending on the type and condition of the unit.

Many factors influence brush wear:

- Spring pressure
- Ring condition
- Current density
- Atmospheric conditions
- Presence of contaminants
- Holder condition
- Brush grade

Replace brushes before they become too short. Frequently inspect the brushes to determine if they need to be replaced by checking the Brush Change Zone. When the Brush Change Zone reaches the edge of the brush box, it's time to change the brush. Do not let the entire Brush Change Zone wear past the edge of the brush box.

In this example, part **A** shows a Brush Change Zone on a new brush and part **B** shows the Brush Change Zone of a brush that is in need of replacement.

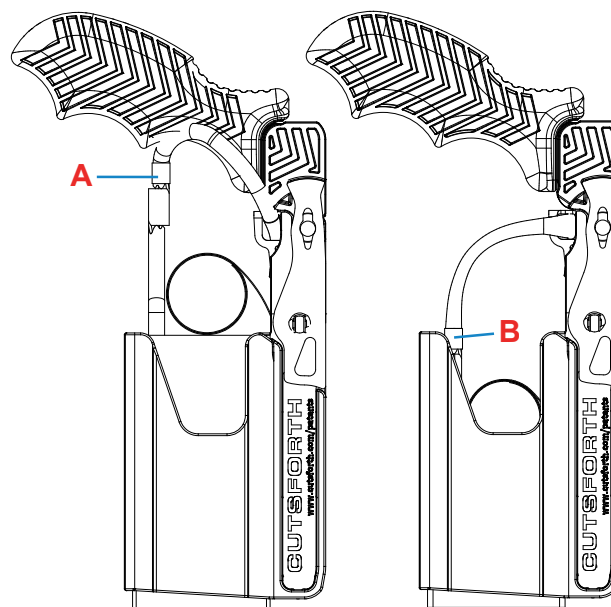



WARNING

Brushes should be changed when the wear indicator band reaches the top edge of the box. Cutsforth does not recommend letting brushes wear past the wear indicator point. Doing so can lead to performance problems up to and including a catastrophic failure. Running short brushes may cause the following issues:

- **Decreased spring pressure:** Spring pressure is constant through the operational life of the brush but will reduce as the brush is worn past the wear indicator. Decreased spring pressure can result in a poor brush-to-ring connection and elevate the risk of arcing, abnormal ring wear, and increased brush vibration.
- **Increased brush binding:** Short brushes are not supported in the brush holder as well as brushes of a proper length and tend to bind in the brush box. The brush leads on short brushes also resist the force of the spring, causing further binding problems. Brush binding will lead to a poor brush-to-ring connection leading to arcing, elevated ring wear, and even a catastrophic failure.
- **Selective action:** Short brushes mixed with proper-length brushes can cause uneven current distribution throughout the brushes and lead to overheating problems.

5. Replacing a Brush Holder



WARNING

Changing brushes on a unit in operation exposes personnel to dangerous voltages. Use approved safety equipment while removing the holder.



CAUTION

Removing multiple holders while the unit is in service can be very dangerous. The current that was flowing through a removed brush is picked up by the remaining brushes. Removing too many holders at once can force excessive current through the remaining brushes resulting in catastrophic failure.

The unlocking motion of the Cutsforth Brush Holder automatically disengages the terminal. This allows for the safe and easy removal of the brush holder with one hand.

Replacing a Cutsforth Brush Holder consists of these main steps:

1. [Removing a Brush Holder \(page 14\)](#)
2. [Inspecting a Brush Holder \(page 15\)](#)
3. [Removing a Brush \(page 16\)](#)
4. [Removing a Brush Spring \(page 19\)](#)
5. [Installing a New Brush \(page 19\)](#)
6. [Returning a Brush Holder to Service \(page 25\)](#)

5.1. Removing a Brush Holder

1. While maintaining control of the brush holder (A), pull the handle (B) and rotate it to the retracted position (C).

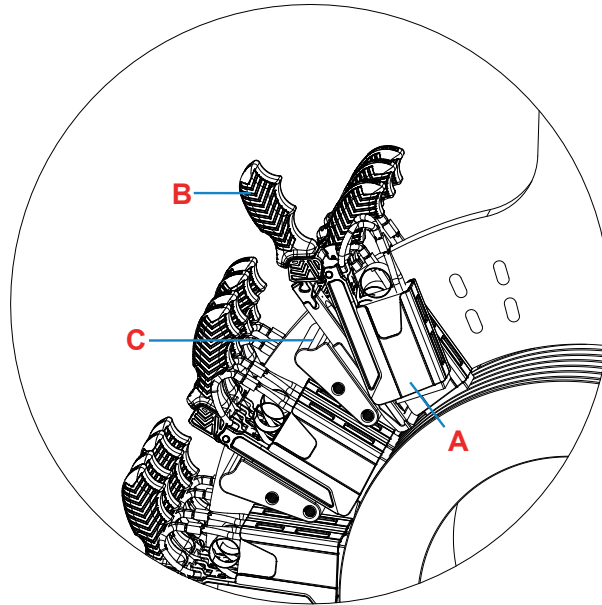

2. Pull the brush holder (A) completely off of the holder mount (D) and ensure the terminal connection area (E) on the mount is not excessively worn or pitted.

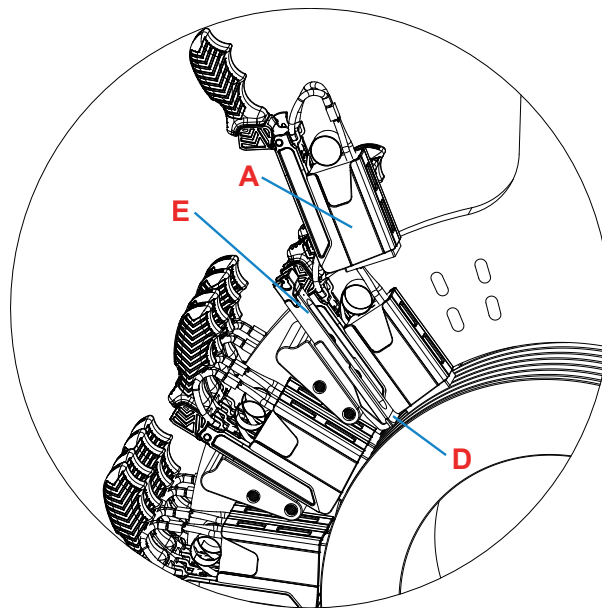

5.2. Inspecting a Brush Holder

5.2.1. Online Inspections

It is normally not necessary to remove a brush holder for inspection prior to changing a worn brush. Watch for the following indicators of a problem:

- Inspect for arcing from the trailing edge of the brush.
- Inspect for discolored brush leads.
- Use a strobe to inspect for brush photographing (imaging) on the ring.

The frequency of inspections is unit specific and ranges from every day to once per week.

5.2.2. Offline Inspections

When the brush holder is removed, complete these inspections to ensure that the brush holder is in proper working condition:

- Inspect the brush holder for any signs of wear or damage as well as any excessive build up of dirt or foreign material.
- Check for any cracking or breakage of components or welds.
- Ensure the brush catch is holding the brush in the brush box when the brush holder is disengaged from its mount. The brush catch is the feature inside the brush box that holds the brush when the holder is out of service.
- Confirm the "snap in" pressure when installing or removing the brush holder is relatively equal to the other brush holders.
- After the brush has been removed, inspect the sides of the brush for any signs of restrictions such as scrapes or drag marks.
- Inspect the inside of the brush box for obstructions such as box deformity, burrs, or carbon deposits. Clean the box using denatured alcohol. Remove carbon deposits using a plastic or wood object. Avoid using sharp objects or abrasive cleaners as these could damage the interior of the brush box.



CAUTION

Denatured alcohol is the only Cutsforth approved cleaning substance for brush holders. The use of alternative cleaning methods may result in equipment damage.

5.3. Removing a Brush

1. Pull the brush terminal **(A)** free from the terminal mount.

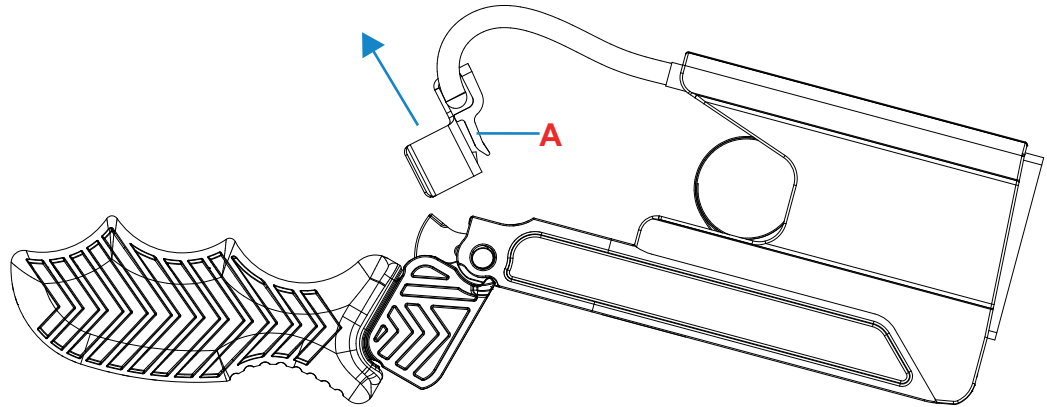

2. Orient the brush key **(B)** to the correct position in reference to the brush holder.

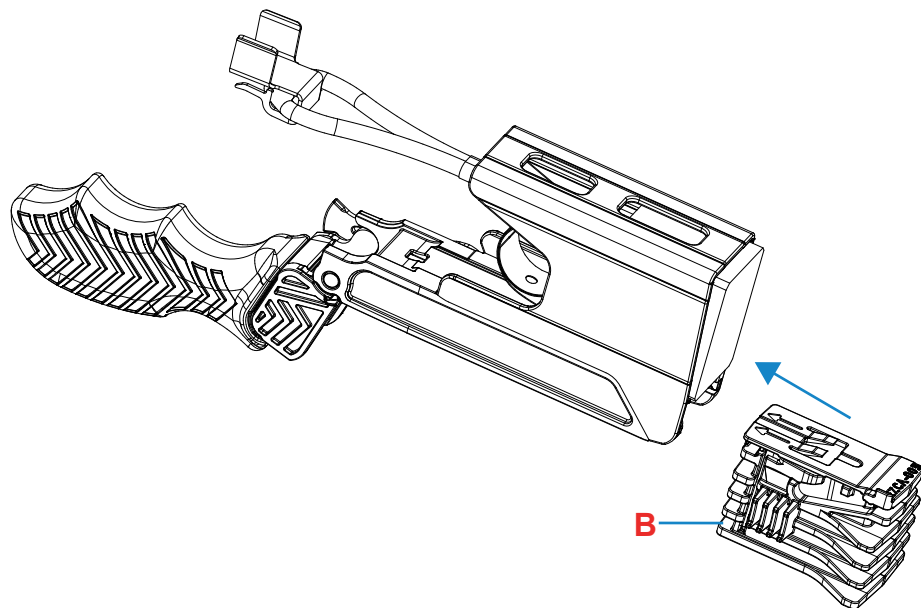

Do NOT insert the brush key in this orientation:

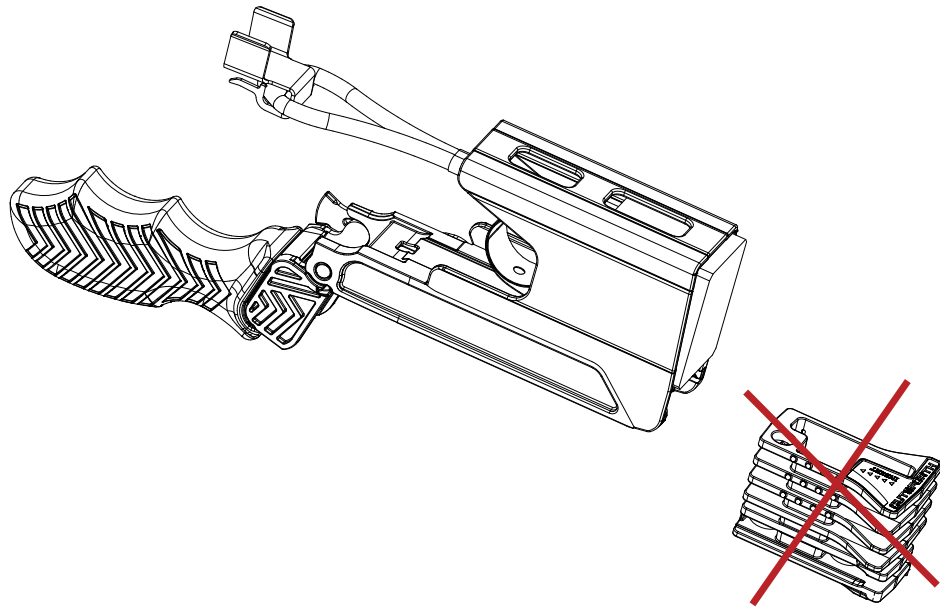

3. Slide the brush key **(B)** into the lower beam **(C)** of the brush holder.

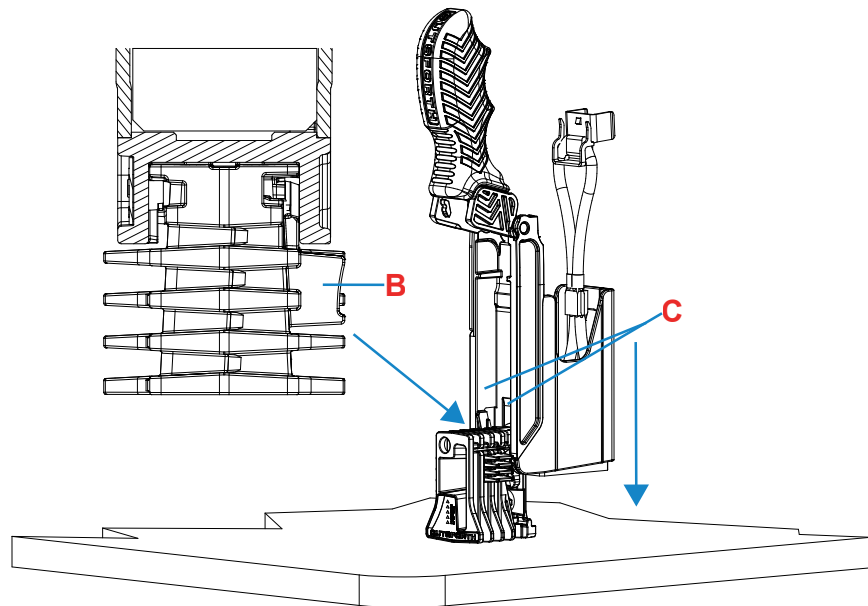

4. Press down onto a flat surface until the brush key **(B)** snaps into the brush holder.

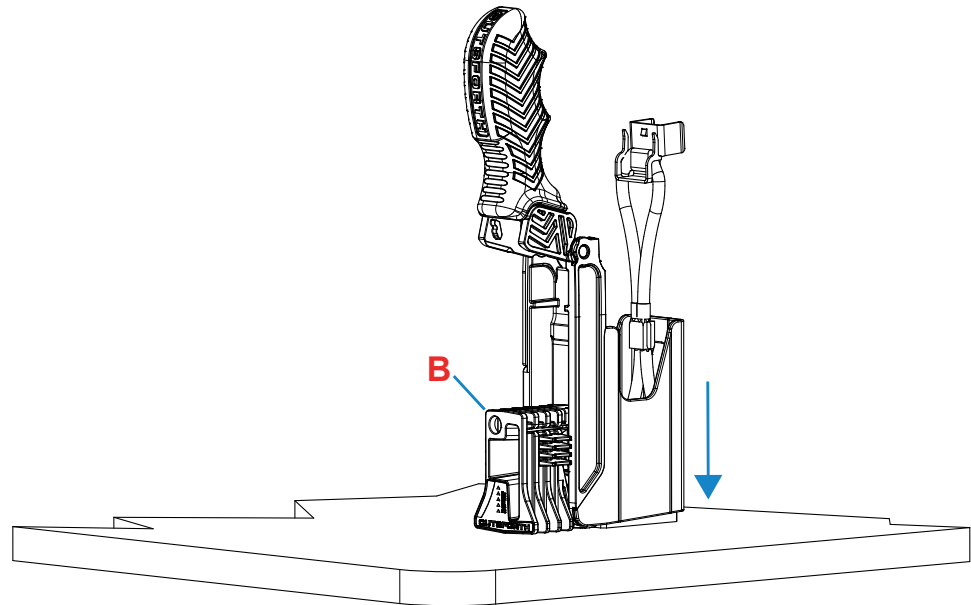

5. When the brush key is fully engaged into the brush holder, the old brush **(D)** easily slides out when you pull away the brush holder.

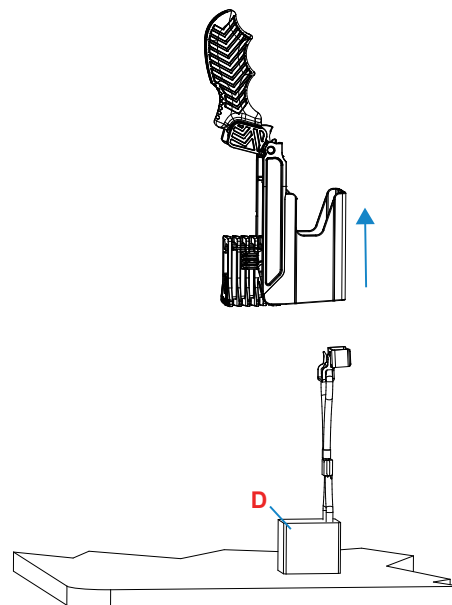

5.4. Removing a Brush Spring

1. Press in on the release tab **(A)** of the brush key **(B)** and pull it out of the brush holder. The brush spring release fingers grab the brush spring as the brush key is pulled out of the brush holder.
2. Remove the old brush spring **(C)** and discard. If you have a spring containing a Brush Health Sensor, the spring and sensor can be reinstalled into the brush holder and reused for the life of the sensor battery.

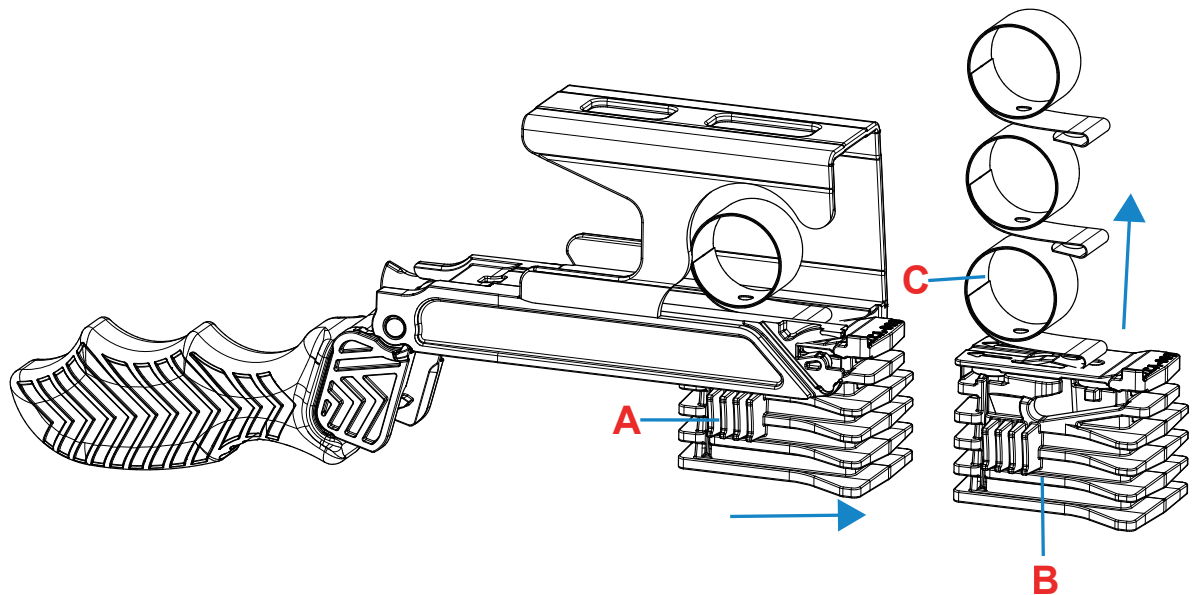

5.5. Installing a New Brush

Complete the steps in these sections to install a new brush:

1. [Install a Brush Spring \(page 20\)](#)
2. [Install a Brush \(page 21\)](#)
3. [Position the Brush Shunts \(page 24\)](#)

5.5.1. Install a Brush Spring

1. Insert a brush spring (A) onto the spring rib (B).
2. Push until the spring hole (C) snaps onto the spring pin (D).

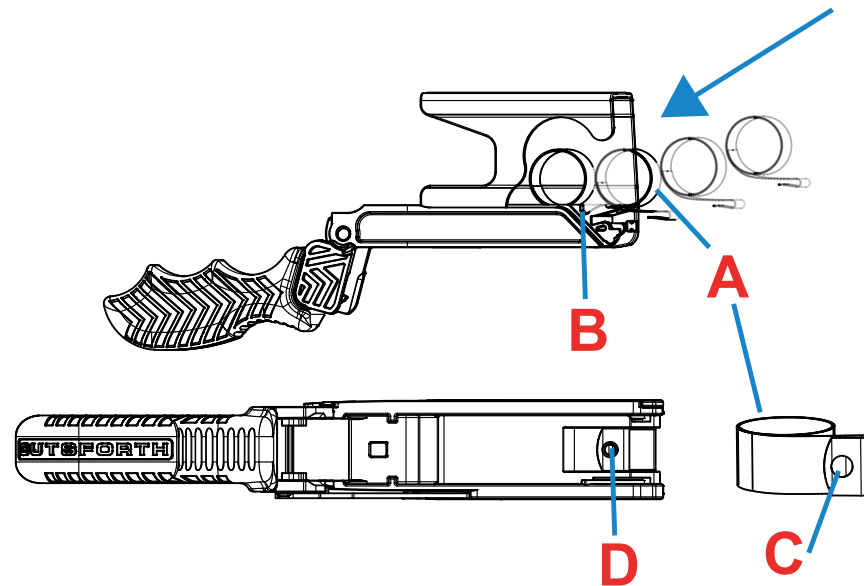

5.5.2. Install a Brush

1. Orient the brush **(A)** so the terminal ears **(B)** point down.

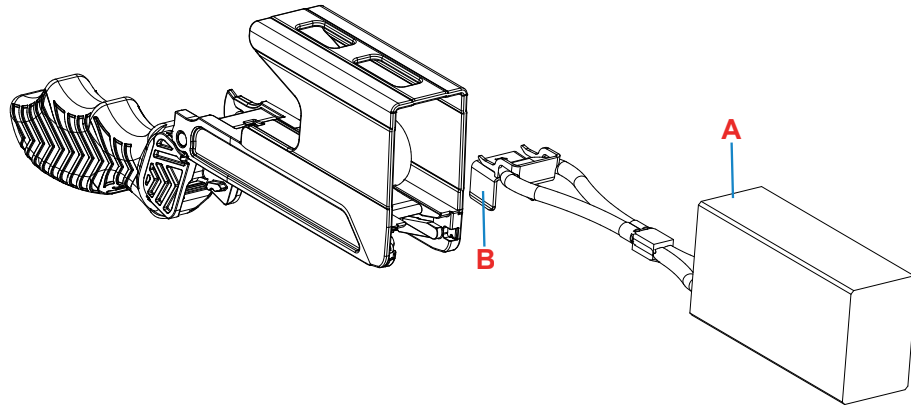

2. Insert the brush **(A)** into the holder **(C)** until the terminal ears **(B)** pass the brush spring.

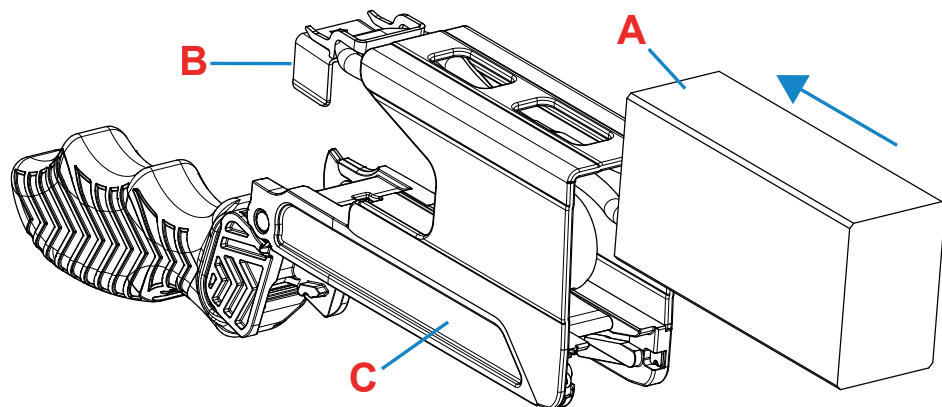

3. Rotate the brush **(A)** so the terminal ears **(B)** point up and start to insert the brush into the holder.

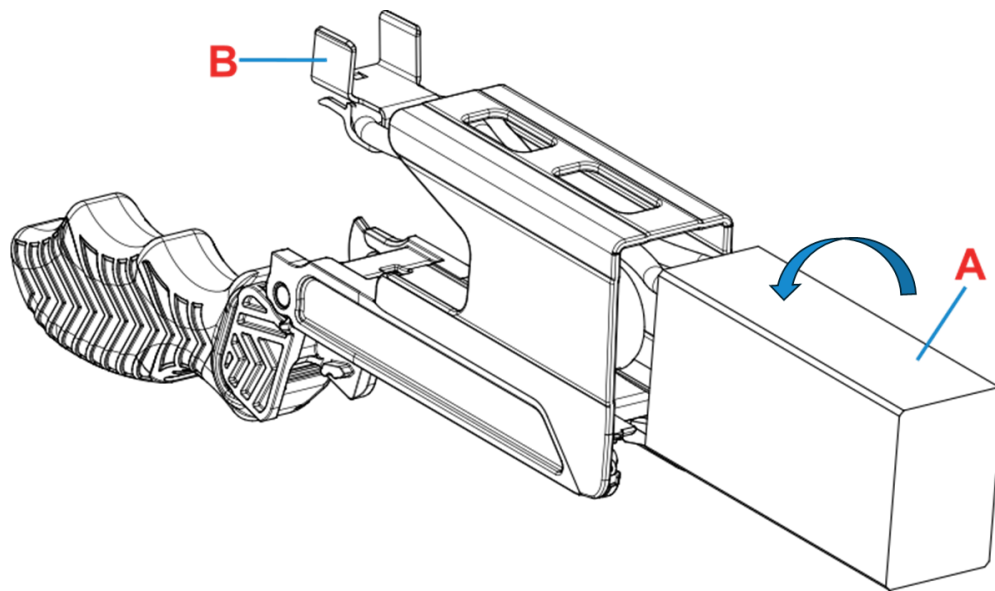

4. Insert the brush the rest of the way into the holder until approximately 1/8 in (3.2 mm) extends out of the brush box, **(A)**.

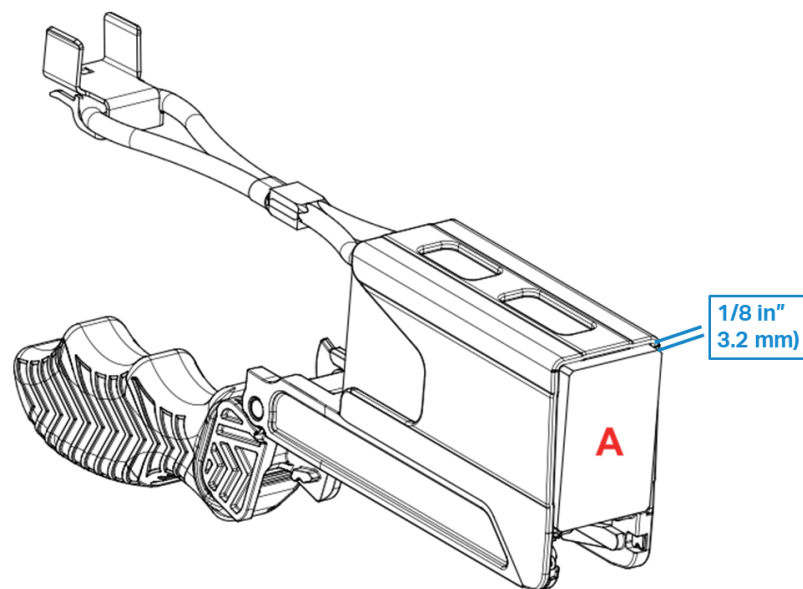

5. Insert the brush terminal **(D)** onto the terminal mount rib **(E)**.

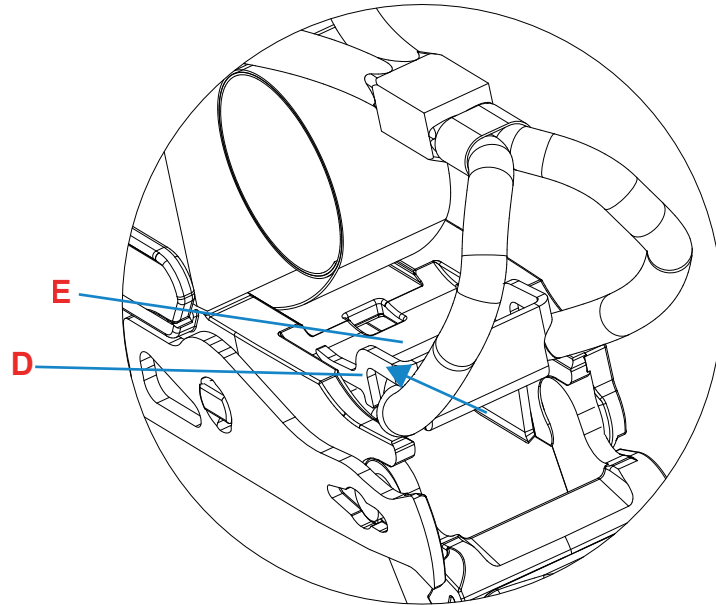

5.5.3. Position the Brush Shunts

- To prevent brush binding, lead damage, and interference with the handle (A), position the brush leads (B) as shown:

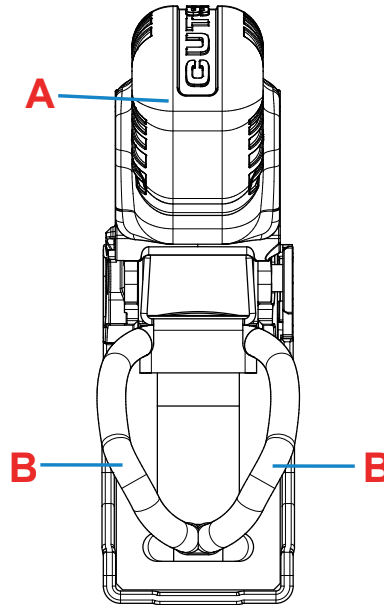

Review these correct/incorrect examples for additional clarification:

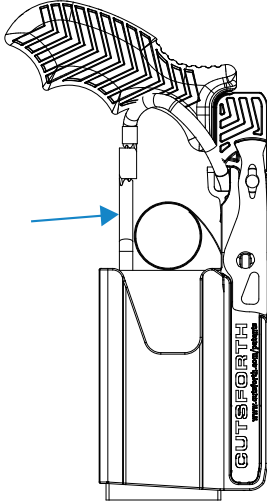
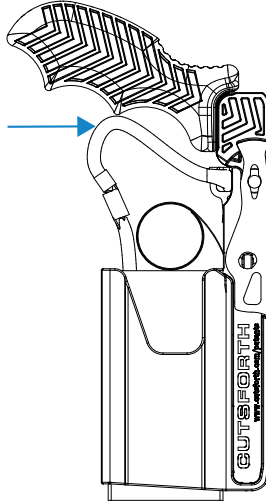
Correct	Incorrect
<p>In this correct example the brush shunts are formed straight up so that they will not catch on the box.</p> 	<p>Do not position the brush leads as this example shows. In this position the leads will restrict free movement of the brush (hang up).</p> 

5.6. Returning a Brush Holder to Service

After a new spring and brush are installed, the holder is ready to be returned to service. Complete the steps in these sections to return the Cutsforth Brush Holder to service:

1. [Install a Brush Holder \(page 26\)](#)
2. [Verify the Brush Holder Installation \(page 27\)](#)

5.6.1. Install a Brush Holder

1. Align the brush holder (A) with the grooves on the side of the holder mount (B) and slide into the holder mount.

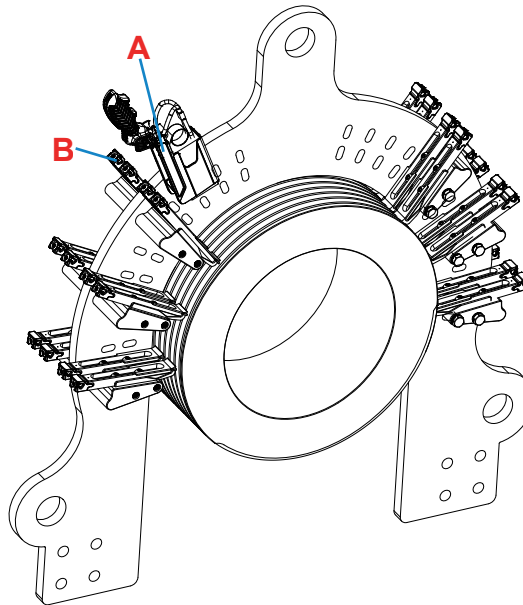

These example images provide additional clarification:

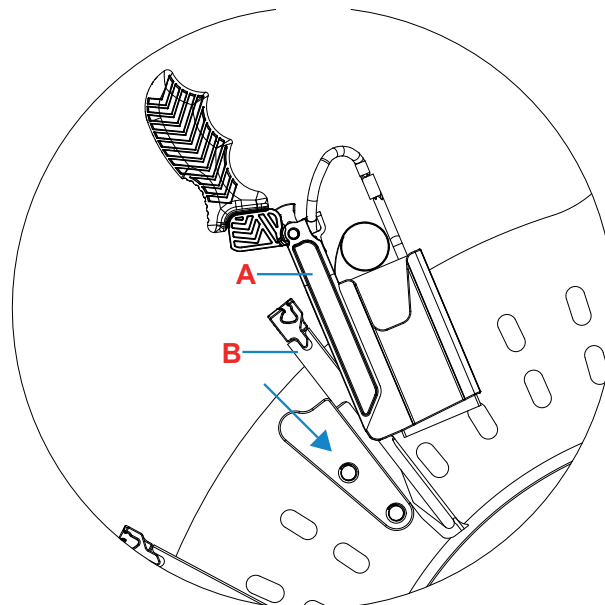

2. Rotate and lock the handle (C) into place while applying light pressure toward the collector ring (D).

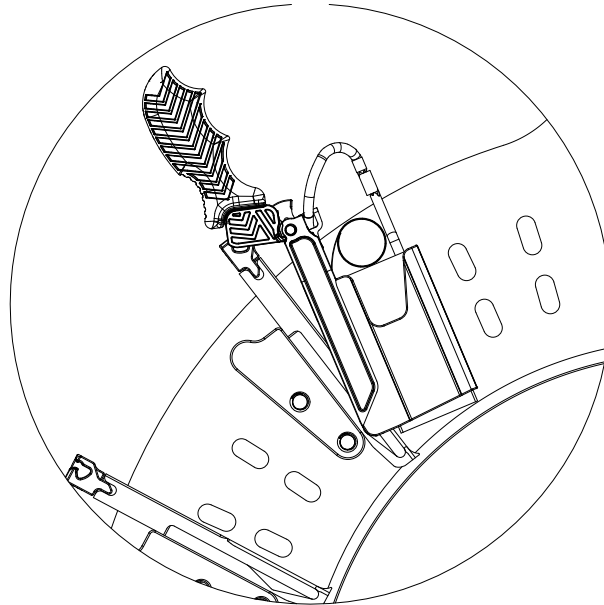

5.6.2. Verify the Brush Holder Installation

This section provides visual examples of correctly and incorrectly installed brush holders.

5.6.2.1. Correctly Mounted Brush Holders

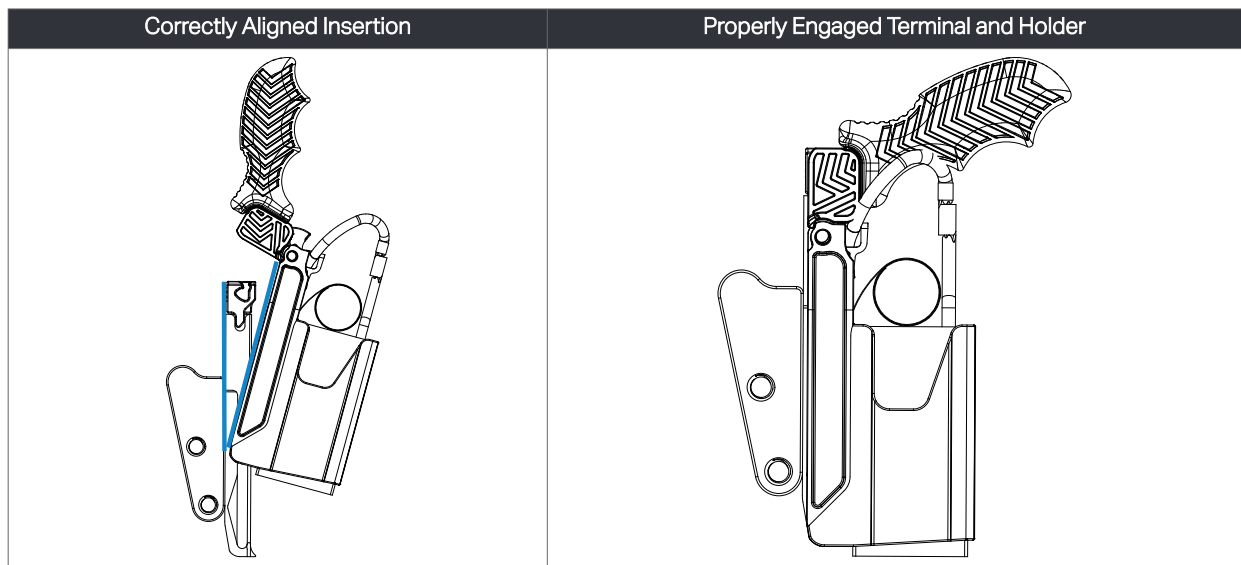

5.6.2.2. Incorrectly Mounted Brush Holders

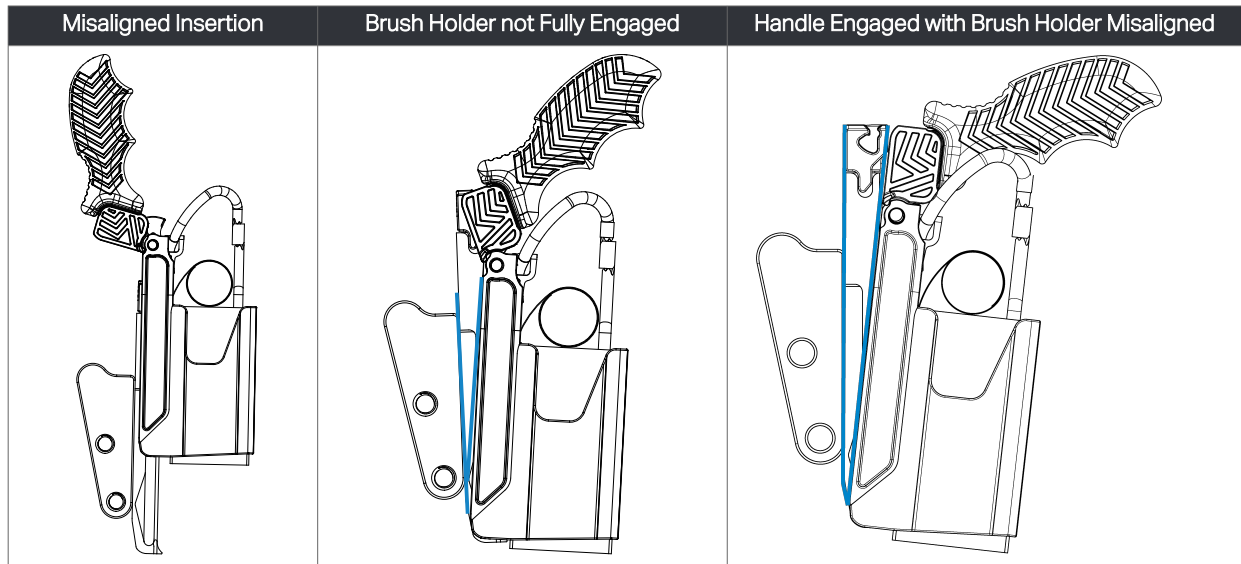

6. Replacing a Holder Mount



ELECTRICAL DANGER

Before working on the holder mounts, de-energize, lock out, and tag out all power sources to the generator, exciter, and accessory devices. Electric shock and death may result due to failure to heed this warning.

When it is necessary to replace or reinstall holder mounts, complete the steps in these sections:

1. [Removing Holder Mounts \(page 29\)](#)
2. [Installing the Holder Mounts \(page 30\)](#)

6.1. Removing Holder Mounts

1. Use a 5/32 in Allen wrench or T27IP torx+ key to remove the 1/4-28 button head cap screws **(A)** and NL6 Nordlock washers **(B)**.

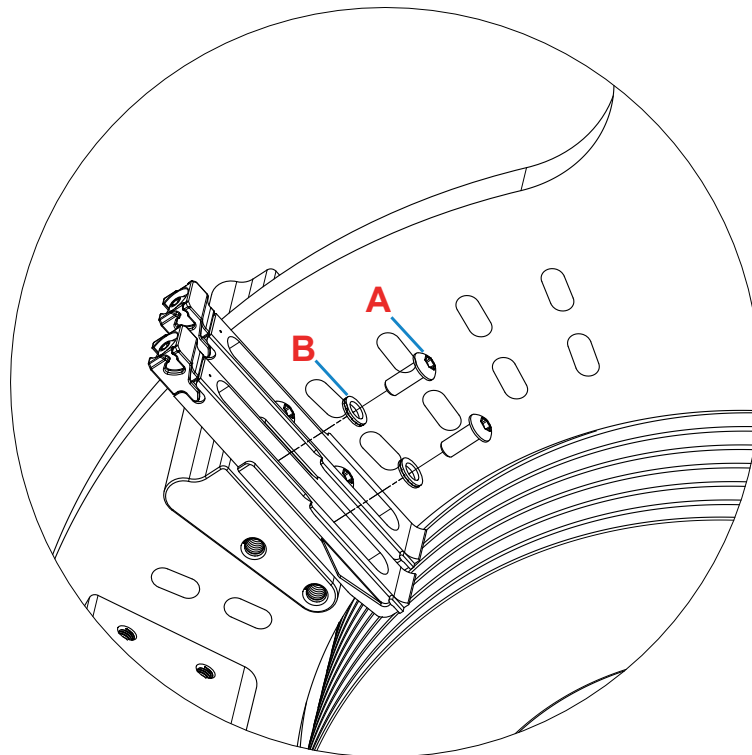

2. Remove the holder mount (C).

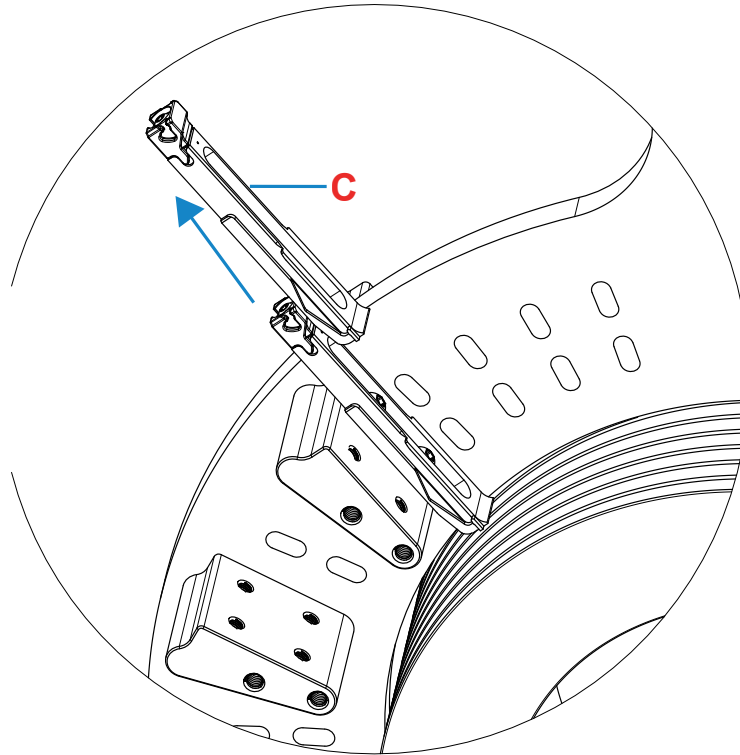

6.2. Installing the Holder Mounts



ELECTRICAL DANGER

Before working on the holder mounts, de-energize, lock out, and tag out all power sources to the generator, exciter, and accessory devices. Electric shock and death may result due to failure to heed this warning.

This section explains how to install the holder mounts using the height setter. The height setter verifies that the holder mount and the brush holders are at the correct distance from the collector ring.

6.2.1. Install a Holder Mount Using the Height Setter

1. While holding the trigger (A) in its disengaged position, slide the height setter (B) onto the holder mount (C) until the guide boss (D) is bottomed out in the guide slot (E).

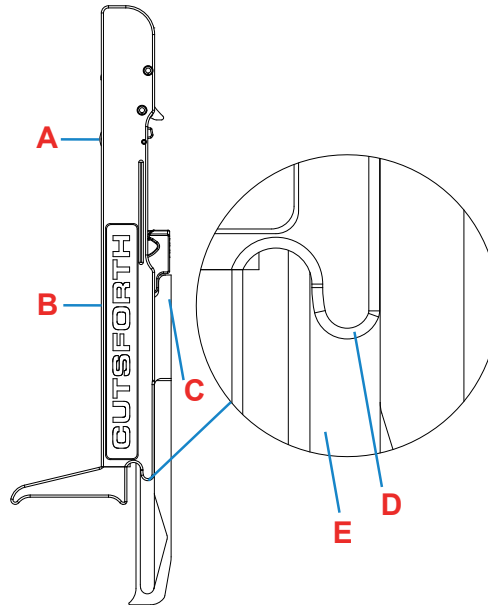

2. With the height setter positioned all the way down, release the trigger (A) and allow it to move to the engaged position (F).

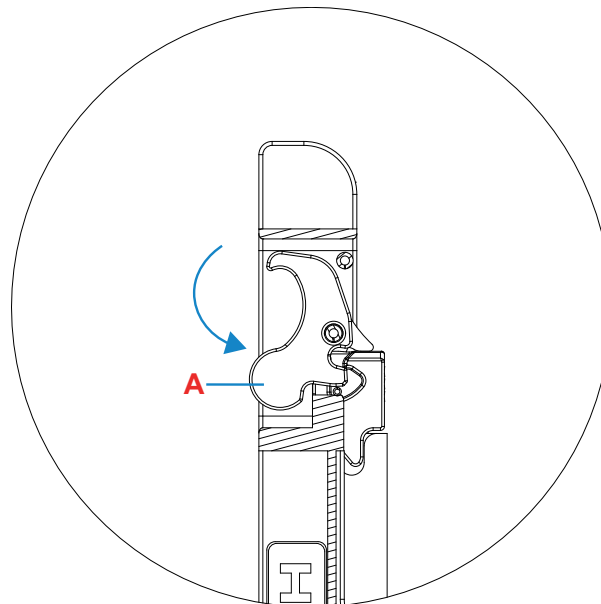

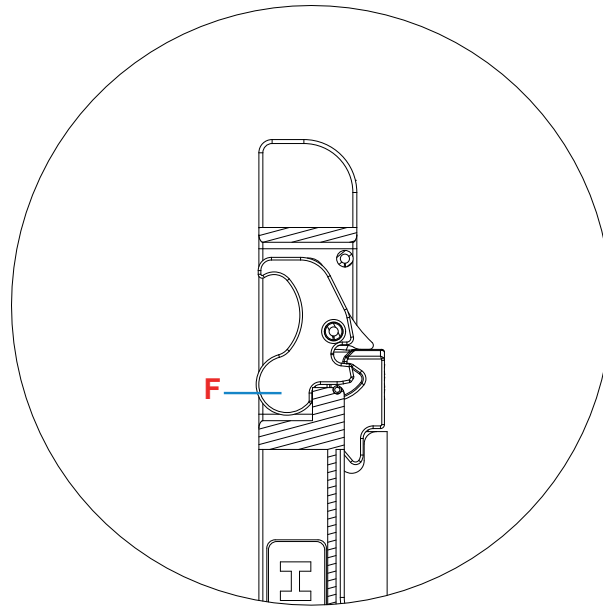

3. Ensure the height setter with holder mount (**B**) is on the mount side of the adapter (**G**). Place the height setter with holder mount against one of the adapters on the yoke (**H**). Position so that the height setter rests against the collector ring (**I**) until both height setter ribs (**J**) contact the collector ring.

The adapter may need a rotational adjustment. To maximize ring coverage, use the alternate mounting positions on the adapters as needed.

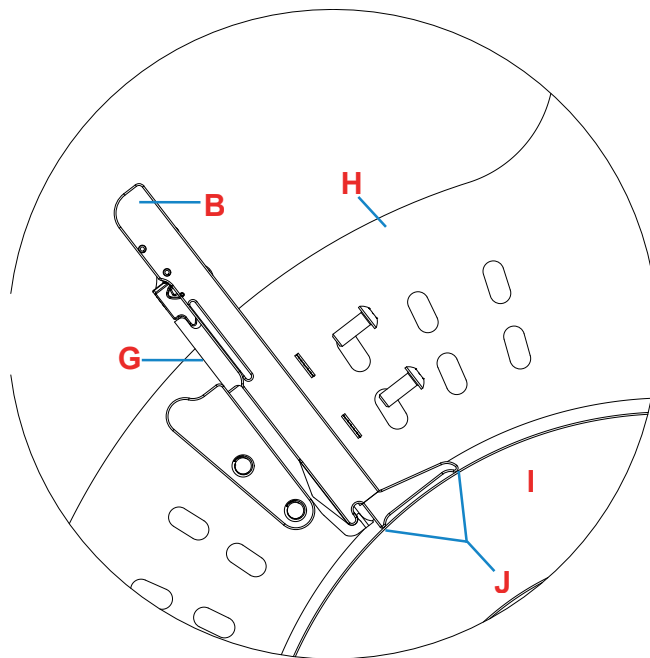

- Using a 5/32 in Allen wrench, fasten the 1/4-28 button head cap screws (**K**) and NL6 Nordlock washers (**L**) to 110-120 in lbs (12-13.5 Nm) of torque.

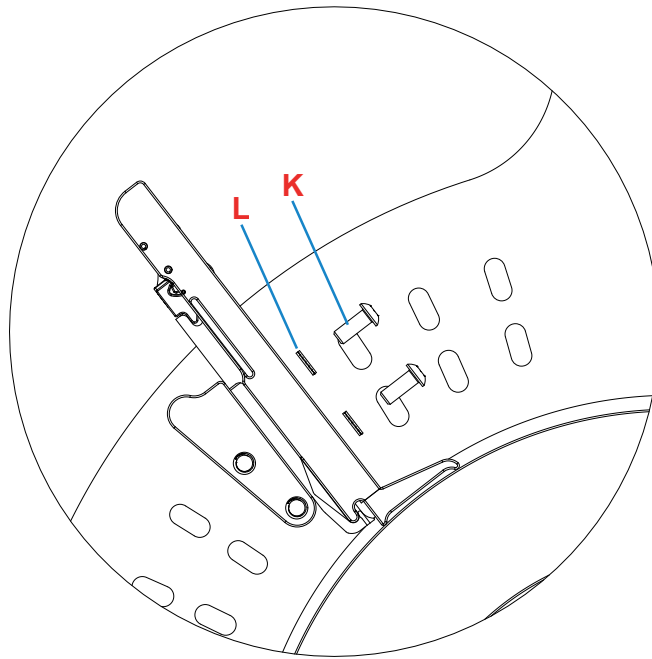

- Pull the trigger back to the disengaged position.

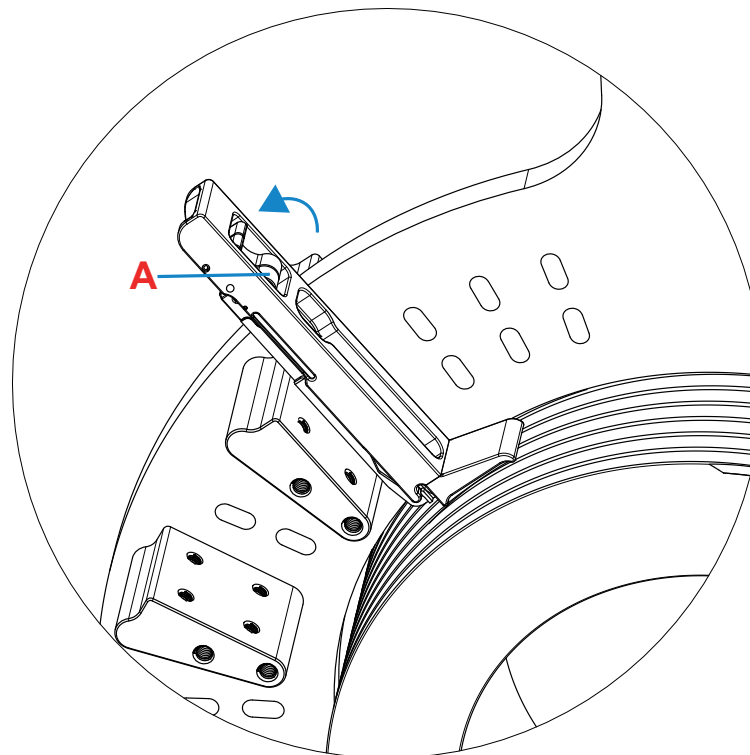

6. Remove the height setter.

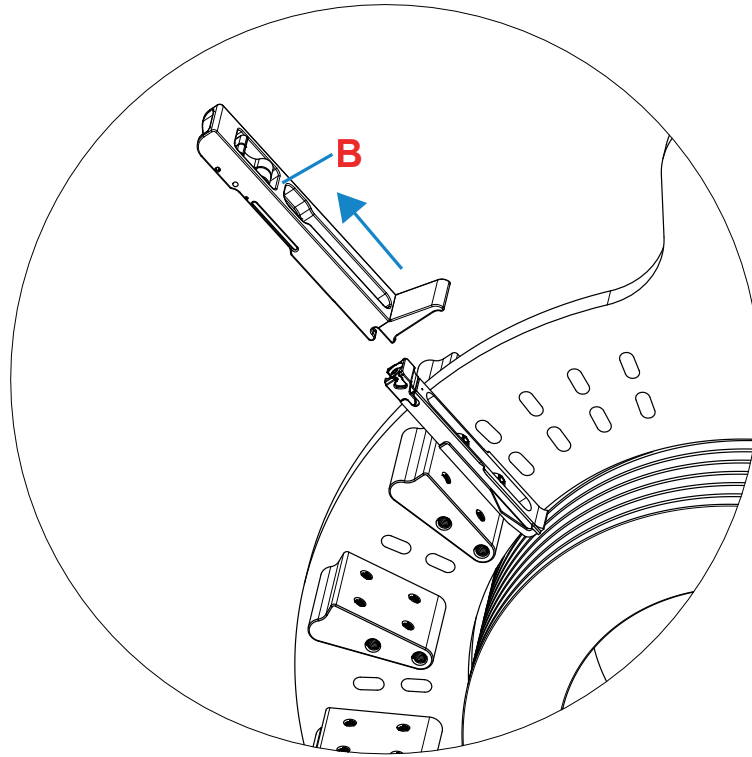

7. Glossary

adapter	A Cutsforth device used as an intermediary connection between the EASYchange Brush Holder and the yoke.
arcing	Electrical discharge caused by the breakdown of a non-conductive medium.
brush change key	A Cutsforth product that assists in removing carbon brushes and constant force springs from an EASYchange Brush Holder.
brush rigging	An assembly that securely holds carbon brush holders in place.
carbon brush	A device which provides a sliding contact used to transmit electrical current to and from static and rotating equipment in a motor or generator.
collector ring (a.k.a. slip ring, main field ring)	The surface upon the rotating equipment to which the carbon brush makes contact to transmit electrical current.
EASYchange Brush Holder	A Cutsforth product and patented brush holder system.
Height Setter	A Cutsforth product used to properly position the lower mount using the surface of the collector ring as a reference.
Lower Mount	A Cutsforth product to which the EASYchange holder mounts, ensuring proper alignment and positioning of the carbon brush to the collector ring running surface.
mil	One thousandth of an inch. An imperial measurement used to communicate vibration reading.
polarity barrier	A structure made from a non-conductive material, which is used to limit proximity and physical access across opposing electrically charged components.
yoke	Structural component of the brush rigging which supports the mounting of brush holders and or adapters.